

Alla rättigheter förbehålls.
 All rights reserved.
 Alle Rechte vorbehalten.

Diese Zeichnung darf weder ganz noch teilweise ohne unsere ausdrückliche Genehmigung kopiert oder auf andere Weise vervielfältigt werden. Werden. Zuwiderhandlungen werden gerichtlich verfolgt.

Denna handling får ej utan vårt medgivande delges annan, kopieras eller eljest obehörigen användas. Överträdelse härvid beivras med stöd av gällande lag. This document must not be copied, either completely or in part, without permission. Any infringement will have legal consequences.

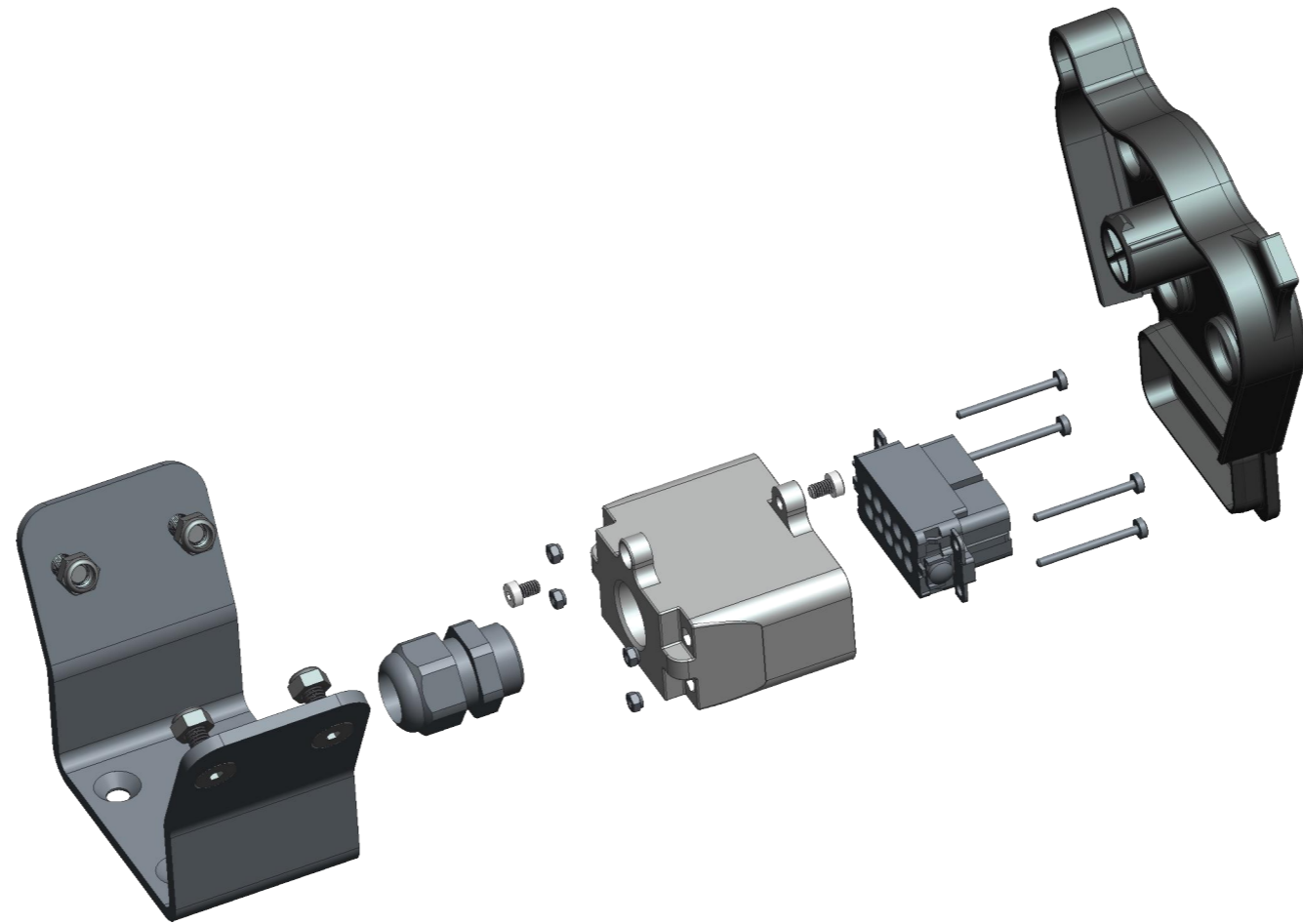
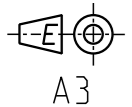

Product no.: 10_932_0012	
Max working pressure:	bar connected bar disconnected
Min burst pressure:	bar connected bar disconnected
Sealing material:	
Temperatur range:	°C - °C
Nominal flow diameter, DN:	mm
Connection	
Connection stroke:	mm

10	4	Screw	Steel FZB	09_932_0904
9	4	Screw	Steel / FZB	09_932_0902
8	2	Screw	Steel / FZB	09_932_0901
7	4	Nut	Steel FZB	09_932_0802
6	4	Lock nut M6	Steel / FZB	09_932_0801
5	1	Fixation plate	Materialnamn i smst	09_932_6503
4	1	Dust cap	PVC	09_932_1011
3	1	Contact insert		09_932_7030
2	1	Connector house	Plastic	09_932_7020
1	1	Cable fitting	Plastic	09_933_7042
Detalj Item	Antal Quant.	Benämning Description	Material Material	Detaljnummer Detail number

CEJN	Skala Scale	1:2	Ritad Drawn	CABJOER	Kontr. Checked	-	Godk. Appr.	-	Äm nr. Alt. no.	-	Dat. Date	131210
	Assembly drawing		Ritning nr./Drawing No.				50_932_0012		Utg./Issue		AA	