

Frame size F12	-030	-040	-060	-080	-090	-110	-125	-152	-162	-182	-250
<b>Displacement</b> [cm <sup>3</sup> /rev]	30.0	40.0	59.8	80.4	93.0	110.1	125.0	149.8	163.1	179.8	242
<b>Operating pressure</b>											
max intermittent <sup>1)</sup> [bar]	480	480	480	480	420	480	480	480	480	480	420
max continuous [bar]	420	420	420	420	350	420	420	420	420	420	350
<b>Motor operating speed</b> [rpm]											
max intermittent <sup>1)</sup>	8600	6700	5800	5300	5000	4800	4600	4000	4000	4000	3000
max continuous <sup>3)</sup>	6700	6100	5300	4800	4600	4400	4200	3700	3700	3700	2700
min continuous	50	50	50	50	50	50	50	50	50	50	50
<b>Max pump selfpriming speed</b> <sup>2)</sup>											
L or R function; max [rpm]	3150	2870	2500	2300	2250	2200	2100	1700	1600	1500	1500
<b>Motor input flow</b>											
max intermittent <sup>1)</sup> [l/min]	219	268	347	426	465	528	575	608	648	728	726
max continuous [l/min]	201	244	317	386	428	484	525	547	583	655	653
<b>Drain temperature</b> <sup>3)</sup> , max [°C]											
min [°C]	-40	-40	-40	-40	-40	-40	-40	-40	-40	-40	-40
<b>Theoretical torque at 100 bar</b> [Nm]	47.6	63.5	94.9	127.6	147.6	174.8	198.4	241	257	289	384.1
<b>Mass moment of inertia</b>											
(x10 <sup>-3</sup> ) [kg m <sup>2</sup> ]	1.7	2.9	5	8.4	8.4	11.2	11.2	21	21	21	46
<b>Weight</b> [kg]	11.5	15.7	18.6	25.7	25.7	33	33	40	40	40	77

- 1) Intermittent: max 6 seconds in any one minute.  
2) Selfpriming speed valid at sea level. Find more info on page 42  
3) See also installation information. Page 69

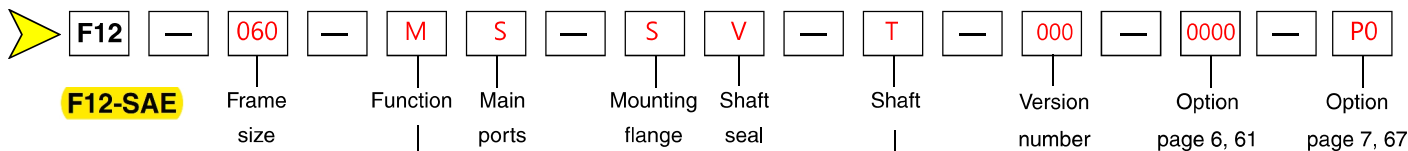

**F12-SAE**

Frame size	
Code	Displacem. (cm <sup>3</sup> /rev)
030	30.0
040	40.0
060	59.8
080	80.4
090	93.0
110	110.1
125	125.0
152	149.8
162	163.1
182	179.8
250	242.0

Version number  
 (assigned for special versions)

Frame size	30	40	60	80	90	110	125	152	162	182	250
<b>Code</b>	<b>Function</b>										
M	Motor	x	x	x	x	x	x	x	x	x	-
S	Motor, high speed	(x)	(x)	(x)	-	-	-	(x)	(x)	(x)	-
Q	Motor	-	-	-	-	-	-	-	-	-	x
R	Pump, clockwise rotation	(x)	(x)	(x)	(x)	(x)	(x)	(x)	(x)	(x)	(x)
L	Pump, counter clockwise rot'n	(x)	(x)	(x)	(x)	(x)	(x)	(x)	(x)	(x)	(x)

Frame size	30	40	60	80	90	110	125	152	162	182	250
<b>Code</b>	<b>Shaft*</b>										
T	SAE key, Standard	x	x	x	x	x	x	x	x	x	x
R	SAE key, Optional	-	-	-	(x)	(x)	-	-	-	-	-
S	SAE Spline, Optional	x	x	x	x	x	x	x	x	x	x
F	SAE Spline, Optional	-	-	-	(x)	(x)	-	-	(x)	(x)	(x)
U	SAE Spline, Optional	-	-	-	(x)	(x)	-	-	-	-	-
K	Metric key, Standard	-	-	-	-	-	-	-	-	-	x
D	Spline DIN 5480	-	-	-	-	-	-	-	-	-	(x)
V	Tapered shaft	(x)	(x)	(x)	-	-	(x)	(x)	-	-	-

\*See also dimensional drawings on pages 52 - 59.

For other versions, contact Parker Hannifin

Frame size	30	40	60	80	90	110	125	152	162	182	250
<b>Code</b>	<b>Main ports</b>										
S	SAE 6000 psi flange	x	x	x	x	x	x	-	-	-	-
U	SAE UN threads <sup>4)</sup>	(x)	(x)	(x)	(x)	(x)	(x)	-	-	-	-
F	SAE 6000 psi flange <sup>2)</sup>	-	-	-	-	-	-	x	x	x	x
D	SAE 6000 psi Horizontal <sup>2)</sup>	-	-	-	-	-	-	(x)	(x)	(x)	-
A	SAE 6000 psi Axial <sup>2)</sup>	-	-	-	-	-	-	(x)	(x)	(x)	-
K	SAE 6000 psi Rear <sup>2)</sup>	-	-	-	-	-	-	(x)	(x)	(x)	-
M	SAE 6000 psi Side <sup>2)</sup>	-	-	-	-	-	-	(x)	(x)	(x)	-

Frame size	30	40	60	80	90	110	125	152	162	182	250
<b>Code</b>	<b>Option</b>										
0000	Standard	x	x	x	x	x	x	x	x	x	x
L130	Flushing valve 1.3 mm orifice	(x)	(x)	(x)	(x)	(x)	<sup>-1)</sup>	<sup>-1)</sup>	-	-	-
MUVR	Make up/Anti cavitation valve clockwise rotation	(x)	-	-	-	-	-	-	-	-	-
MUVR	Make up/Anti cavitation valve counter clockwise rotation	(x)	-	-	-	-	-	-	-	-	-
P <sub>3)</sub> R	Pressure relief valve clockwise rotation	(x)	(x)	(x)	-	-	-	-	-	-	-
P <sub>3)</sub> L	Pressure relief valve counter clockwise rotation	(x)	(x)	(x)	-	-	-	-	-	-	-

Frame size	30	40	60	80	90	110	125	152	162	182	250
<b>Code</b>	<b>Mounting flange</b>										
S	SAE 4 bolt	x	x	x	x	x	x	x	x	x	x
R	SAE 4 bolt	-	-	-	(x)	(x)	-	-	-	-	-
T	SAE 2 bolt	x	x	x	-	-	-	-	-	-	-

Frame size	30	40	60	80	90	110	125	152	162	182	250
<b>Code</b>	<b>Option</b>										
00	Standard	-	-	-	-	-	-	-	-	-	x
P <sub>-</sub>	Prepared for speed sensor	x	x	x	x	x	x	x	x	x	(x)
B <sub>-</sub>	Power Boost and Prepared for speed sensor	(x)	-	-	-	-	-	-	-	-	-
_T	Painted Black	(x)	(x)	(x)	(x)	(x)	(x)	(x)	(x)	(x)	(x)

x : Available      (x) : Optional      - : Not available

- 1) F12-110 and -125: Accessory valve block (page 62)
- 2) Metric threads
- 3) Pressure setting on page 63
- 4) Not in combination with any valve options

**NOTE:** All combinations are not valid, please contact Parker Hannifin

Frame size	30	40	60	80	90	110	125	152	162	182	250
<b>Code</b>	<b>Shaft seal</b>										
V	FPM, high pressure, high temperature	x	x	x	x	x	x	x	x	x	x

For other versions, contact Parker Hannifin



**F12-30, -40, -60, -80, -90, -110 and -125**  
 (SAE versions with 4 bolt flange)

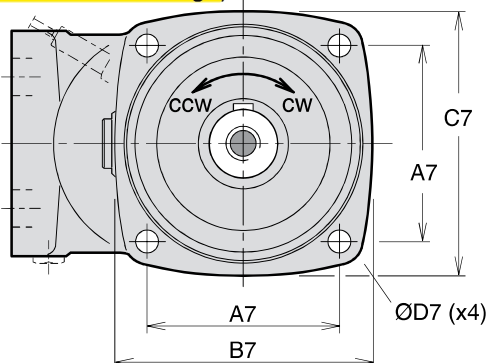

**Type S (SAE 4 bolt) mounting flange**

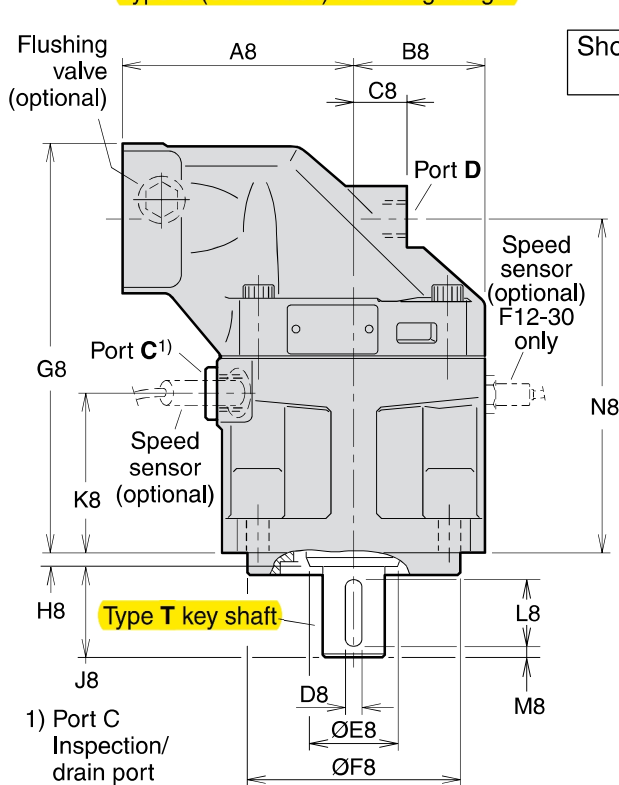
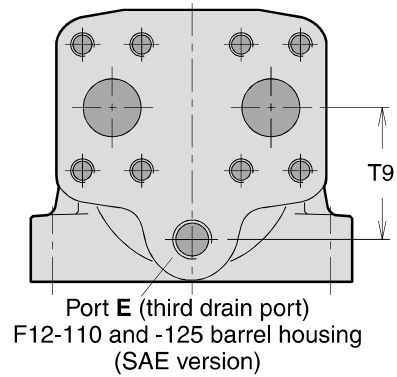

Shown: F12-80 with 4 bolt flange

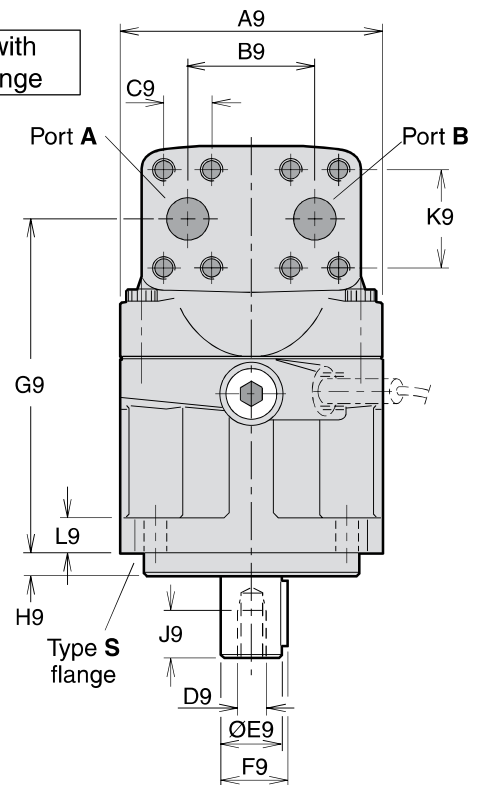

**Shaft option S (U)**

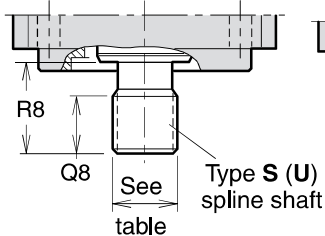

**Shaft option V (F12-30)**

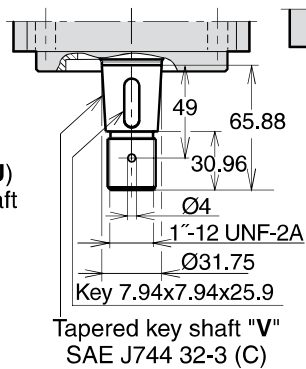

**Shaft option V (F12-40)**

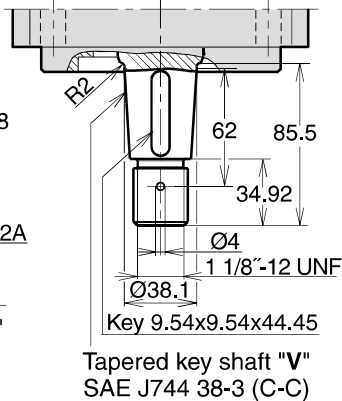

**Shaft option V (F12-60)**

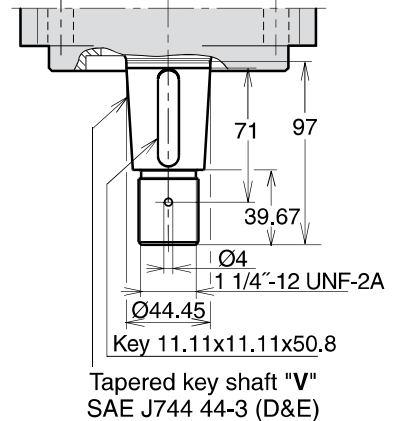

Dim.	F12-30	F12-40	F12-60	F12-80 F12-90	F12-110 F12-125
A7	89.8	114.5	114.5	114.5	161.6
B7	118	148	148	155	204
C7	118	144	144	155	200
D7	14	14	14	14	21
A8	100	110	125	135	145
B8	59	65	70	77.5	85
C8	25	26	22	32	38
D8	6.35	7.94	7.94	9.53	11.1
E8	33	42	42	52	57.5
F8	101.60/ 101.55	127.00/ 126.94	127.00/ 126.94	127.00/ 126.94	152.40/ 152.34
G8	189.5	197	214	240	264
H8	8	8	8	8	8
J8	38	48	48	54	67
K8	72	76	79	95	99
L8	31.8	38.1	38.1	44.5	54.1
M8	2.5	4	4	4	7.5
N8	153.5	161	178.3	197.1	212
Q8 <sup>1)</sup>	26	27	27	29	39
Q8 <sup>2)</sup>	-	-	-	23	-
R8 <sup>1)</sup>	33	48	48	54	66.7
R8 <sup>2)</sup>	-	-	-	48	-
A9	122	134	144	155	170
B9	66	66	66	75	83
C9	23.8	23.8	23.8	27.8	31.8
D9*	5/16"-24	3/8"-24	3/8"-24	1/2"-20	5/8"-18
E9	25.40/ 25.35	31.75/ 31.70	31.75/ 31.70	38.10/ 38.5	44.45/ 44.40
F9	28.2	35.3	35.3	42.3	49.4
G9	153.8	161	178.3	197.1	212
H9	9.7	12.7	12.7	12.7	12.7
J9	16	19	19	26	32
K9	50.8	50.8	50.8	57.2	66.7
L9	18	20	20	20	22
T9	-	-	-	-	68

\* UNF-2B thread

1) Spline shaft type **S**

2) Spline shaft type **U**

3) Max operating pressure 350 bar

Main ports A and B, type U (optional)	
F12-30	1 1/16" - 12 UN <sup>3)</sup>
F12-40	1 5/16" - 12 UN <sup>3)</sup>
<b>F12-60</b>	<b>1 5/16" - 12 UN<sup>3)</sup></b>
F12-80	1 5/16" - 12 UN <sup>3)</sup>
F12-90	1 5/16" - 12 UN <sup>3)</sup>
F12-110	1 5/8" - 12 UN <sup>3)</sup>
F12-125	1 5/8" - 12 UN <sup>3)</sup>

Ports	F12-30	F12-40	F12-60	F12-80 F12-90	F12-110 F12-125
A, B size	3/4"	3/4"	3/4"	1"	1 1/4"
Screw thread**)	3/8"-16 x22	3/8"-16 x20	3/8"-16 x22	7/16"-14 x27	1/2"-13 x25
C thread	7/8"-14	7/8"-14	7/8"-14	7/8"-14	1 1/16"-12
D thread	3/4"-16	3/4"-16	7/8"-14	7/8"-14	1 1/16"-12
E thread	-	-	-	-	1 1/16"-12

A, B: ISO 6162 C, D, E: O-ring boss (SAE J514)

\*\*\*) UN thread x depth in mm.

**Mounting flange (SAE J744)**

	S (standard)	R (optional)
F12-30	SAE 'B', 4 bolt	-
-40	SAE 'C', 4 bolt	-
<b>-60</b>	<b>SAE 'C', 4 bolt</b>	-
-80	SAE 'C', 4 bolt	SAE 'D', 4 bolt
-90	SAE 'C', 4 bolt	SAE 'D', 4 bolt
-110	SAE 'D', 4 bolt	-
-125	SAE 'D', 4 bolt	-

**Spline shaft (SAE J498b, class 1, flat root, side fit)**

	S (standard)	U (opt.)	F (optional)
F12-30	SAE 'B' 13T, 16/32 DP	-	-
-40	SAE 'C' 14T, 12/24 DP	-	-
-60	SAE 'C' 14T, 12/24 DP	-	-
-80	SAE 'C-C' 17T, 12/24 DP	SAE 'C' 14T, 12/24 DP <sup>3)</sup>	SAE 'D' 13T, 8/16 DP
-90	SAE 'C-C' 17T, 12/24 DP	SAE 'C' 14T, 12/24 DP <sup>3)</sup>	SAE 'D' 13T, 8/16 DP
-110	SAE 'D' 13T, 8/16 DP	-	-
-125	SAE 'D' 13T, 8/16 DP	-	-

**Key shaft (SAE J744)**

F12	T (standard)	R (optional)	V (optional)
-30	SAE 'B-B' (Ø25.4 mm/1")	-	32-3
-40	SAE 'C' (Ø31.75 mm/1 1/4")	-	38-3
<b>-60</b>	<b>SAE 'C' (Ø31.75 mm/1 1/4")</b>	-	44-3
-80	SAE 'C-C' (Ø38.1 mm/1 1/2")	SAE 'D' (Ø44.45 mm/1 3/4")	-
-90	SAE 'C-C' (Ø38.1 mm/1 1/2")	SAE 'D' (Ø44.45 mm/1 3/4")	-
-110	SAE 'D' (Ø44.45 mm/1 3/4")	-	44-3
-125	SAE 'D' (Ø44.45 mm/1 3/4")	-	44-3