

Frame size F12	-030	-040	-060	-080	-090	-110	-125	-152	-162	-182	-250
<b>Displacement</b> [cm <sup>3</sup> /rev]	30.0	40.0	59.8	80.4	93.0	110.1	125.0	149.8	163.1	179.8	242
<b>Operating pressure</b>											
max intermittent <sup>1)</sup> [bar]	480	480	480	480	420	480	480	480	480	480	420
max continuous [bar]	420	420	420	420	350	420	420	420	420	420	350
<b>Motor operating speed</b> [rpm]											
max intermittent <sup>1)</sup>	8600	6700	5800	5300	5000	4800	4600	4000	4000	4000	3000
max continuous <sup>3)</sup>	6700	6100	5300	4800	4600	4400	4200	3700	3700	3700	2700
min continuous	50	50	50	50	50	50	50	50	50	50	50
<b>Max pump selfpriming speed</b> <sup>2)</sup>											
L or R function; max [rpm]	3150	2870	2500	2300	2250	2200	2100	1700	1600	1500	1500
<b>Motor input flow</b>											
max intermittent <sup>1)</sup> [l/min]	219	268	347	426	465	528	575	608	648	728	726
max continuous [l/min]	201	244	317	386	428	484	525	547	583	655	653
<b>Drain temperature</b> <sup>3)</sup> , max [°C]											
min [°C]	-40	-40	-40	-40	-40	-40	-40	-40	-40	-40	-40
<b>Theoretical torque at 100 bar</b> [Nm]	47.6	63.5	94.9	127.6	147.6	174.8	198.4	241	257	289	384.1
<b>Mass moment of inertia</b>											
(x10 <sup>-3</sup> ) [kg m <sup>2</sup> ]	1.7	2.9	5	8.4	8.4	11.2	11.2	21	21	21	46
<b>Weight</b> [kg]	11.5	15.7	18.6	25.7	25.7	33	33	40	40	40	77

1) Intermittent: max 6 seconds in any one minute.

2) Selfpriming speed valid at sea level. Find more info on page 42

3) See also installation information. Page 69

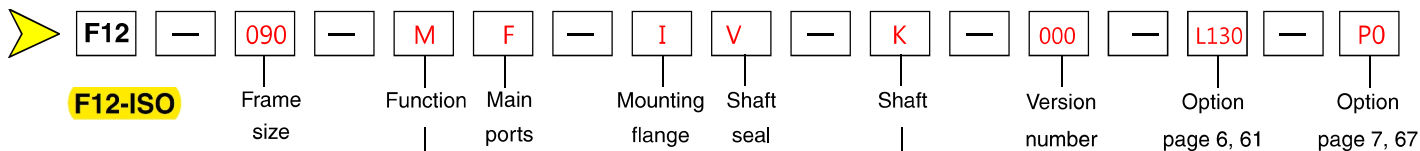

**F12-ISO**

Frame size	
Code	Displacem. (cm <sup>3</sup> /rev)
030	30.0
040	40.0
060	59.8
080	80.4
090	93.0
110	110.1
125	125.0
152	149.8
162	163.1
182	179.8

Frame size	30	40	60	80	90	110	125	152	162	182
<b>Code</b>	<b>Function</b>									
M	Motor	x	x	x	x	x	x	x	x	x
S	Motor, high speed	(x)	(x)	(x)	-	-	-	(x)	(x)	(x)
R	Pump, clockwise rotation	(x)	(x)	(x)	(x)	(x)	(x)	(x)	(x)	(x)
L	Pump, counter clockwise rot'n	(x)	(x)	(x)	(x)	(x)	(x)	(x)	(x)	(x)

For other versions, contact Parker Hannifin

Frame size	30	40	60	80	90	110	125	152	162	182
<b>Code</b>	<b>Main ports</b>									
F	SAE 6000 psi flange	x	x	x	x	x	x	x	x	x
D	SAE 6000 psi Horizontal	-	-	-	-	-	-	(x)	(x)	(x)
A	SAE 6000 psi Axial	-	-	-	-	-	-	(x)	(x)	(x)
K	SAE 6000 psi Rear	-	-	-	-	-	-	(x)	(x)	(x)
M	SAE 6000 psi Side	-	-	-	-	-	-	(x)	(x)	(x)

Frame size	30	40	60	80	90	110	125	152	162	182
<b>Code</b>	<b>Mounting flange</b>									
I	ISO flange	x	x	x	x	x	x	x	x	x
F	ISO 200 flange	-	-	-	-	-	-	x	x	x

x: Available      (x): Optional      - : Not available

1) F12-110 and -125: Accessory valve block (page 62)

2) Pressure setting on page 63

**NOTE:** All combinations are not valid, please contact Parker Hannifin

Version number  
 (assigned for special versions)

Frame size	30	40	60	80	90	110	125	152	162	182
<b>Code</b>	<b>Shaft*</b>									
D	DIN Spline, Standard	x	x	x	x	x	x	x	x	x
A	DIN Spline, Optional	-	(x)	-	-	-	-	-	-	-
Z	DIN Spline, Optional	(x)	(x)	(x)	(x)	(x)	(x)	(x)	(x)	(x)
K	Metric key, Standard	x	x	x	x	x	x	x	x	x
J	Metric key, Optional	-	(x)	-	-	-	-	-	-	-
H	DIN Spline, Optional	-	-	-	-	-	-	(x)	(x)	(x)
G	Metric key, Optional	-	-	-	-	-	-	(x)	(x)	(x)
P	Metric key, Optional	(x)	-	-	-	-	-	(x)	(x)	(x)
V	Tapered shaft	(x)	(x)	(x)	-	-	(x)	(x)	-	-

\*See also dimensional drawings on pages 46 and 48.

Frame size	30	40	60	80	90	110	125	152	162	182
<b>Code</b>	<b>Option</b>									
0000	Standard	x	x	x	x	x	x	x	x	x
L130	Flushing valve 1.3 mm orifice	(x)	(x)	(x)	(x)	(x)	- <sup>1)</sup>	- <sup>1)</sup>	-	-
MUVR	Make up/Anti cavitation valve clockwise rotation	(x)	-	-	-	-	-	-	-	-
MUVL	Make up/Anti cavitation valve counter clockwise rotation	(x)	-	-	-	-	-	-	-	-
P <sub>2)</sub> R	Pressure relief valve clockwise rotation	(x)	(x)	(x)	-	-	-	-	-	-
P <sub>2)</sub> L	Pressure relief valve counter clockwise rotation	(x)	(x)	(x)	-	-	-	-	-	-

Frame size	30	40	60	80	90	110	125	152	162	182
<b>Code</b>	<b>Option</b>									
P0	Prepared for speed sensor	x	x	x	x	x	x	x	x	x
PT	Prepared for speed sensor and Painted Black	(x)	(x)	(x)	(x)	(x)	(x)	(x)	(x)	(x)
B0	Power Boost and Prepared for speed sensor	(x)	-	-	-	-	-	-	-	-
BT	Power Boost, Prepared for speed sensor and Painted Black	(x)	-	-	-	-	-	-	-	-

Frame size	30	40	60	80	90	110	125	152	162	182
<b>Code</b>	<b>Shaft seal</b>									
V	FPM, high pressure, high temperature	x	x	x	x	x	x	x	x	x

For other versions, contact Parker Hannifin

**3**

**F12-30, -40, -60, -80, -90, -110 and -125**  
 (ISO versions)

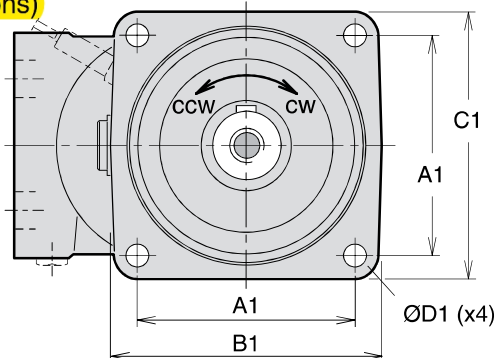

Type I mounting flange  
 (ISO 3019/2)

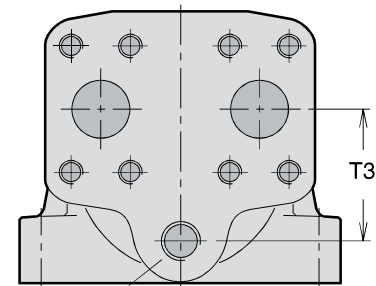

Port E (third drain port)  
 F12-110 and -125 barrel housing  
 (ISO /cartridge version)

F12-80 shown

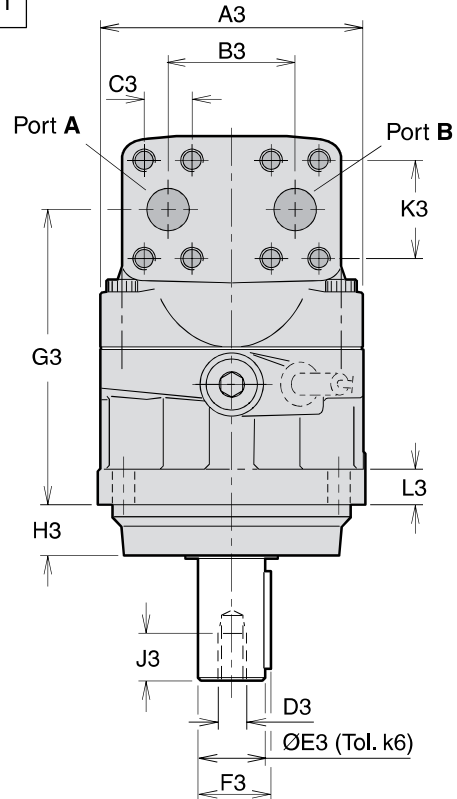
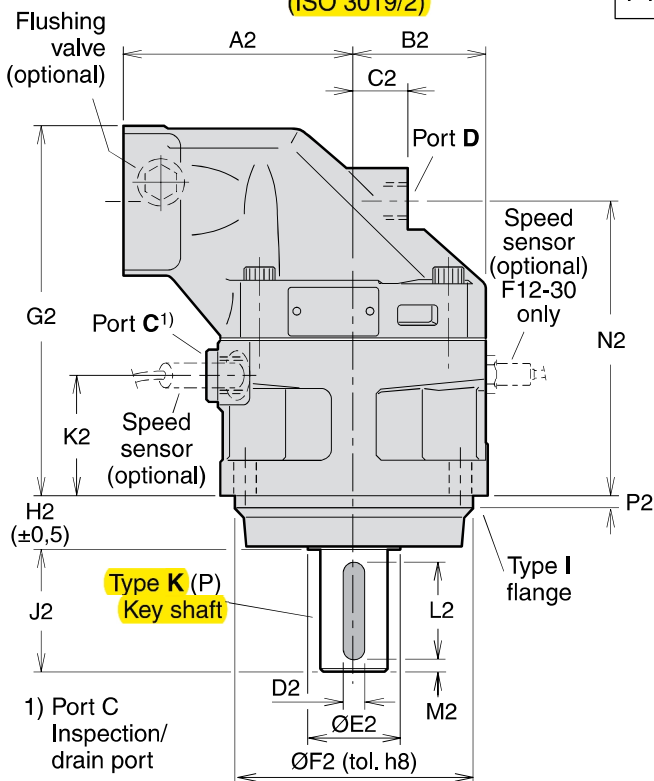

**Shaft option D (Z)**

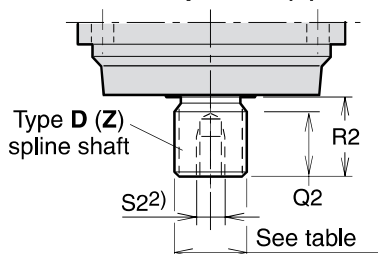

2) Type Z has no thread

**Shaft option V (F12-30)**

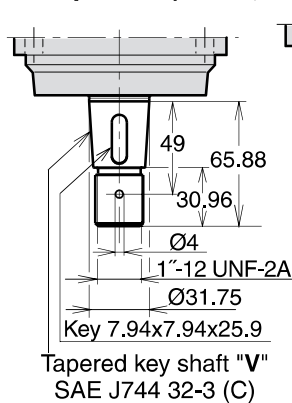

Tapered key shaft "V"  
 SAE J744 32-3 (C)

**Shaft option V (F12-40)**

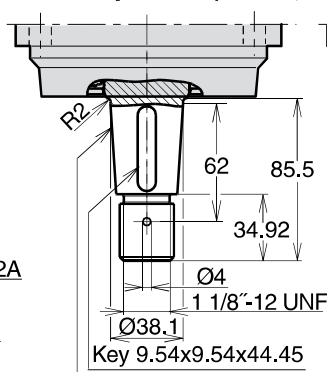

Tapered key shaft "V"  
 SAE J744 38-3 (C-C)

**Shaft option V (F12-60)**

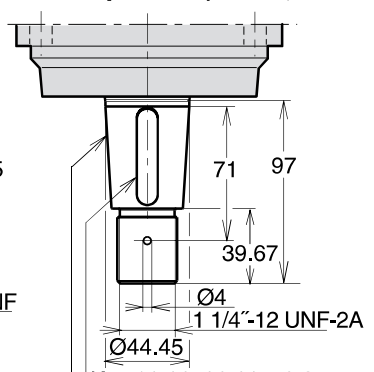

Tapered key shaft "V"  
 SAE J744 44-3 (D&E)

Dim.	F12-30	F12-40	F12-60	F12-80 F12-90	F12-110 F12-125
A1	88.4	113.2	113.2	127.2	141.4
B1	118	146	146	158	180
C1	118	142	144	155	180
D1	11	13.5	13.5	13.5	18
A2	100	110	125	135	145
B2	59	65	70	78	85
C2	25	26	22	32	38
D2	8	8	10	12	14
E2	33	42	42	52	58
F2	100	125	125	140	160
G2	172	173	190	216	231
H2	25.5	32.5	32.5	32.5	40.5
J2	50	60	60	70	82
K2	55	52	54	70.5	66.5
L2	40	50	50	56	70
M2	5	5	5	7	6
N2	136.5	137	154	172.5	179
P2	8	8	8	8	8
Q2	28	28	33	36	41
R2 <sup>1)</sup>	35	35	40	45	50
R2 <sup>2)</sup>	43	35	35	35	45
S2 <sup>1)</sup>	M12 x24	M12 x24	M12 x28	M16 x36	M16 x36
S2 <sup>2)</sup>	-	M12 x24	-	M12 x28	-
A3	122	134	144	155	170
B3	66	66	66	75	83
C3	23.8	23.8	23.8	27.8	31.8
D3	M12	M12	M12	M16	M16
E3	30	30	35	40	45
F3	33	33	38	43	49
G3	136.5	137	154	172.5	179
H3	23.5	30.5	30.5	30.5	38.5
J3	24	24	28	36	36
K3	50.8	50.8	50.8	57.2	66.7
L3	18	20	20	20	22
T3	-	-	-	-	68

- 1) Spline shaft type D  
2) Spline shaft type Z  
3) Max operating pressure 350 bar

Ports	F12-30	F12-40	F12-60	F12-80 F12-90	F12-110 F12-125
A, B size	3/4"	3/4"	3/4"	1"	1 1/4"
Screw thread <sup>*)</sup>	M10 x20	M10 x20	M10 x20	M12 x20	M14 x26
C thread <sup>**)</sup>	M22 x1.5	M22 x1.5	M22 x1.5	M22 x1.5	M22 x1.5
D thread <sup>**)</sup>	M18 x1.5	M18 x1.5	M22 x1.5	M22 x1.5	M22 x1.5
E thread	-	-	-	-	M22 x1.5

A, B: ISO 6162    \*) Metric thread x depth in mm  
\*\*) Metric thread x pitch in mm.

### Spline shaft (DIN 5480)

	Type D (std)	Type A	Type Z (optional)
F12-30	W30x2x14x9g	-	W25x1.25x18x9g <sup>3)</sup>
-40	W32x2x14x9g	W35x2x16x9g	W30x2x14x9g
-60	W35x2x16x9g	-	W32x2x14x9g
-80	W40x2x18x9g	-	W35x2x16x9g <sup>3)</sup>
-90	W40x2x18x9g	-	W35x2x16x9g <sup>3)</sup>
-110	W45x2x21x9g	-	W40x2x18x9g <sup>3)</sup>
-125	W45x2x21x9g	-	W40x2x18x9g <sup>3)</sup>

### Key shaft

	Type K (std)	Type P (opt.)	Type J (opt.)	Type V (opt.)
F12-30	Ø30	Ø25 <sup>3)</sup>	-	32-3
-40	Ø30	-	Ø35	38-3
-60	Ø35	-	-	44-3
-80	Ø40	-	-	-
-90	Ø40	-	-	-
-110	Ø45	-	-	44-3
-125	Ø45	-	-	44-3

**Integrated flushing valve (F12-30, -40, -60, -80, -90)**

**General information**

The integrated flushing valve supplies the motor with a cooling flow through the case which may be required when operating at high speeds and power levels.

In a closed loop hydrostatic transmission the flushing valve secures that cool fluid from the charge circuit is constantly added to the main circuit.

The flushing valve consists of a 'three-position', three-way spool valve which connects the low pressure side of the main hydraulic circuit with the motor case. The valve opens at a pressure differential between port A and port B of approximately 14 bar.

In order to limit the flow, a nozzle with a orifice is available from Parker Hannifin. The diagram to the right shows flow versus differential pressure.

For general advise when flushing might be needed, see page 67.

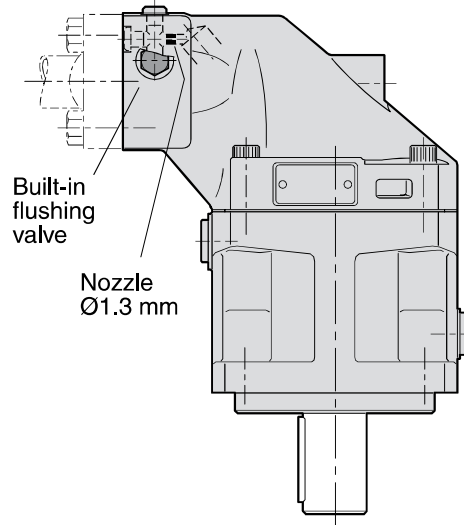

**4**

**Integrated flushing valve (F12-30, -40, -60, -80, -90)**  
**Nozzle Ø1.3 mm**

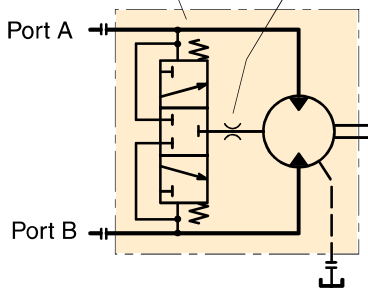

Hydraulic schematic.

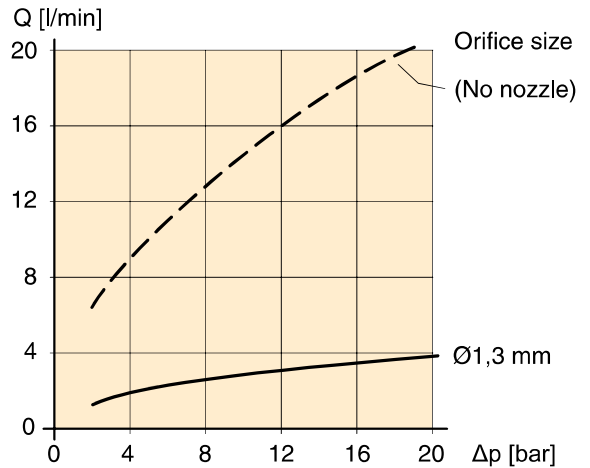

Flow versus pressure differential (port A or B to tank).

**Ordering code**

**F12 - 080 - MF - IV - K - 000 - L130 - P0**

Standard F12 ordering code  
 (for F12-30, -40, -60, -80, -90)

Code	Nozzle designation
L 130	1,3 mm

**NOTE:** FV13 flushing valve block for F12-110 shown on next page.