

Specifications

| Frame size T1- | 81 | 121 |
|--|--------------------|--------------------|
| Displacement [cm ³ /rev] | 81.5 | 118.5 |
| Max flow ¹⁾ [l/min] | 163 ³⁾ | 190 ³⁾ |
| Max operating pressure [bar] | | |
| continuous | 250 | 250 |
| intermittent | 350 | 350 |
| Shaft speed [rpm] | | |
| - short circuited pump (low press.) | 2300 | 2300 |
| max speed ²⁾ | 2000 ³⁾ | 1600 ³⁾ |
| Torque ¹⁾ [Nm] | | |
| at 200 bar | 258 | 376 |
| at 350 bar | 453 | 658 |
| Input power [kW] | | |
| - continuous | 54 | 71 |
| - intermittent ⁴⁾ | 67 | 89 |
| Weight [kg] | 8.5 | 12.5 |

- 1) Theoretical values
- 2) Valid at an inlet pressure of 1.0 bar (abs.) when operating on mineral oil at a viscosity of 30 mm²/s (cSt).
- 3) Valid with 2 1/2" inlet (suction) line. With 2" suction line:
 T1-81 – max 1400 rpm (Q ≈ 120 l/min);
 T1-121 – max 950 rpm (Q ≈ 120 l/min).
- 4) Max 6 seconds in any one minute.

NOTE:
 For noise level information, contact Parker Hannifin.

Pump cross section

(T1-121 shown)

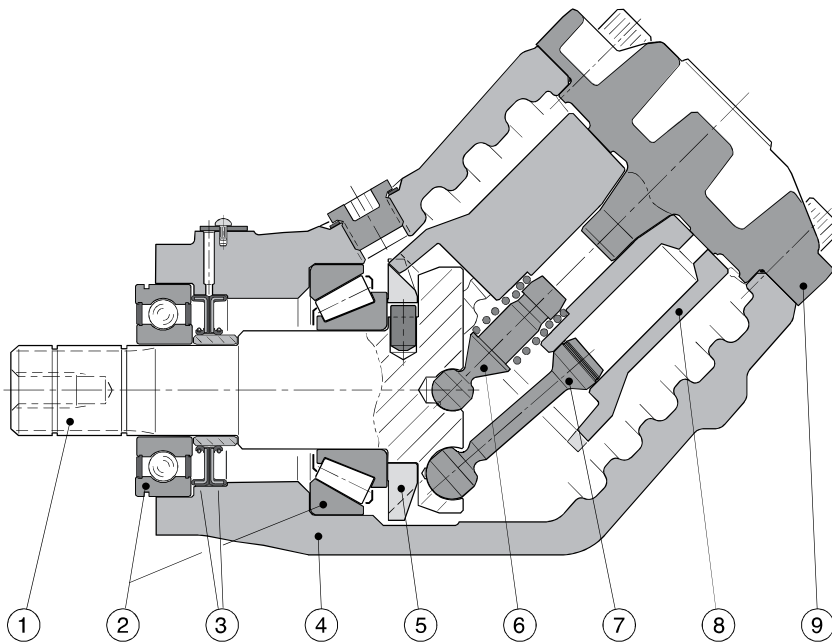

1. Input shaft
2. Bearings
3. Shaft seals

4. Housing
5. Timing gear
6. Barrel support

7. Piston with piston ring
8. Cylinder barrel
9. End cap

T1-81

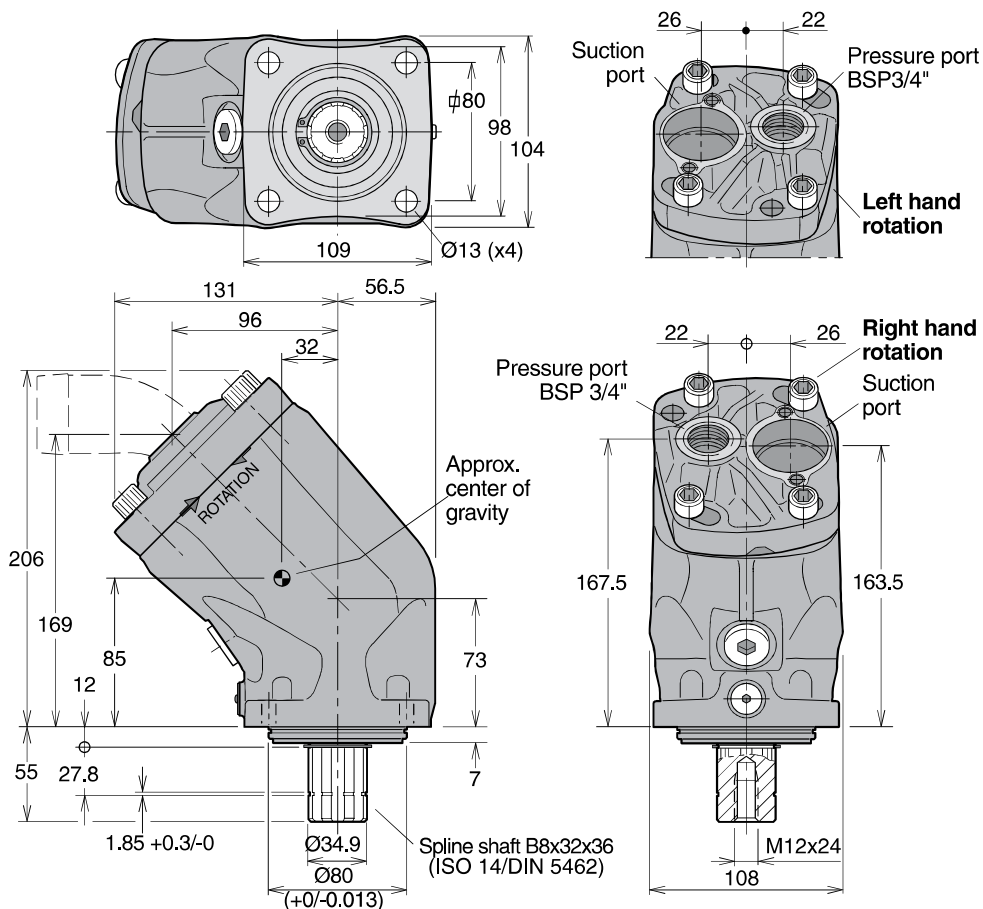

5

Ordering code

Example: **T1 - 81 - R**

T1 frame size **81** or 121

Shaft rotation **R** Right hand
L Left hand

Standard versions

| Designation | Ordering no. |
|----------------|-----------------|
| T1-81-R | 378 2180 |
| T1-81-L | 378 2181 |
| T1-121-R | 378 2120 |
| T1-121-L | 378 2121 |

Port size

| T1 frame size | Pressure port ¹⁾ |
|---------------|-----------------------------|
| -81 | 3/4" |
| -121 | 1" |

1) BSP thread (fitting not included).

NOTE: The pump **does not** include a suction fitting; it must be ordered separately. See chapter 11.