

HYDRAULIC GEAR
PUMPS AND
MOTORS

POLARIS[®]

HOW TO ORDER POLARIS 20 SINGLE UNITS

PLM20.16 R 0 - 54 E2 - L GD/GE - N - EL - - - -
 1 2 3 4 5 6 7 8 9 10 11 12 13
 - PLP 20-4 - L - 0 - - 82 - E2 - L - EA/EA - N - EL - G - - * - GB - - FS -

1	Type	Pump type	Motor type
	0.30 in ³ /rev (4,95 cm ³ /rev)	PLP 20-4	PLM 20-4
	0.40 in ³ /rev (6,61 cm ³ /rev)	PLP 20-6,3	PLM 20-6,3
	0.44 in ³ /rev (7,29 cm ³ /rev)	PLP 20-7,2	PLM 20-7,2
	0.50 in ³ /rev (8,26 cm ³ /rev)	PLP 20-8	PLM 20-8
	0.56 in ³ /rev (9,17 cm ³ /rev)	PLP 20-9	PLM 20-9
	0.66 in ³ /rev (10,9 cm ³ /rev)	PLP 20-10,5	PLM 20-10,5
	0.69 in ³ /rev (11,23 cm ³ /rev)	PLP 20-11,2	PLM 20-11,2
	0.89 in ³ /rev (14,53 cm ³ /rev)	PLP 20-14	PLM 20-14
	1.03 in ³ /rev (16,85 cm ³ /rev)	PLP 20-16	PLM 20-16
	1.16 in ³ /rev (19,09 cm ³ /rev)	PLP 20-19	PLM 20-19
	1.29 in ³ /rev (21,14 cm ³ /rev)	PLP 20-20	PLM 20-20
	1.52 in ³ /rev (24,84 cm ³ /rev)	PLP 20-24,5	PLM 20-24,5
	1.61 in ³ /rev (26,42 cm ³ /rev)	PLP 20-25	PLM 20-25
	1.72 in ³ /rev (28,21 cm ³ /rev)	PLP 20-27,8	PLM 20-27,8
	2.01 in ³ /rev (33,03 cm ³ /rev)	PLP 20-31,5	PLM 20-31,5

2	Rotation	Code
	Left	S
	Right	D
	Reversible rear external drain	R
	Reversible side external drain	L
	Reversible internal drain	B

3	Version	Code
	Without outboard bearing	0
	With outboard bearing	W8
	With outboard bearing	4
	With outboard bearing	5
	With outboard bearing	6
	With outboard bearing	7
	With outboard bearing	8
	With outboard bearing	9

4	Drive shaft	Code
	European tapered 1:8	82
	German tapered 1:5	54
	German tapered 1:5	55
	Straight	46
	SAE "A" spline (9 teeth)	03
	SAE spline (10 teeth)	01
	SAE "A" spline (11 teeth)	07
	SAE "A" straight	31

Code	Drive shaft	4
49	Straight	
50	Straight	
04	SAE "B" spline	
32	SAE "B" straight	
12	DIN 54 82	
48	Straight (only for version 6)	
B1	Straight (only for version 8)	
95	Tang	

Code	Mounting flange	5
E2	European	
B2	German	
B4	German 2 bolt	
B5	German 2 bolt	
B6	German 4 bolt	
S1	SAE "A" 2 bolt	
S2	SAE "A" 2 bolt	
S9	SAE "A" 2 bolt	
S5	SAE "B" 2 bolt	
W8	German	

Code	Ports position	6
L	Side	
P	Rear	

Code	Ports IN/OUT	7
GERMAN FLANGED PORTS		
Side	Rear	Type
BE/BC	PLP 20	4-6,3-7,2-8-9-10,5-11,2
BC/BE	PLM 20	14-16-19-20-24,5-25 27,8-31,5
EUROPEAN FLANGED PORTS		
Side	Rear	Type
EA/EA	PLP 20	4-6,3-7,2-8-9-10,5-11,2
	PLM 20	
EB/EA	PLP 20	14-16-19-20-24,5-25
EA/EB	PLM 20	27,8-31,5

01/10.03

HOW TO ORDER POLARIS 20 SINGLE UNITS

Replaces: 01/10.03

7	Ports IN/OUT	Code
SAE FLANGED PORTS (SSM)		
Type	Side	Rear
4-6,3-7,2-8-9-10,5-11,2	PLP 20	MA/MA
	PLM 20	MA/MA
14-16-19-20	PLP 20	MB/MA
	PLM 20	MA/MB
24,5-25-27,8-31,5	PLP 20	MC/MB
	PLM 20	MB/MC
SAE FLANGED PORTS (SSS)		
Type	Side	Rear
4-6,3-7,2-8-9-10,5-11,2	PLP 20	SA/SA
	PLM 20	SA/SA
14-16-19-20	PLP 20	SB/SA
	PLM 20	SA/SB
24,5-25-27,8-31,5	PLP 20	SC/SB
	PLM 20	SB/SC
GAS STRAIGHT THREAD PORTS (BSPP)		
Type	Side	Rear
4-6,3-7,2-8-9 10,5-11,2	PLP 20	GD/GD
	PLM 20	GD/GD
14-16-19-20-24,5-25-27,8-31,5	PLP 20	GE/GD
	PLM 20	GD/GE
SAE STRAIGHT THREAD PORTS (ODT)		
Type	Side	Rear
4-6,3-7,2-8-9-10,5-11,2	PLP 20	OC/OC
	PLM 20	OC/OC
14-16-19-20-24,5-25-27,8-31,5	PLP 20	OD/OC
	PLM 20	OC/OD

8	Seals (a)	Code
	Buna (standard)	N
	Viton	V

9	Cover options (b)	Code
	Cast iron mounting flange and rear cover (standard - no code)	
	Aluminium mounting flange and cast iron rear cover	E
	Cast iron mounting flange and aluminium rear cover	L
	Aluminium mounting flange and rear cover	EL

10	Shaft seal options	Code
	High back pressure seal with wiper seal	C
	Standard seal with wiper seal	D
	High back pressure seal	H

Code	Drain port position - Rev. rotation L	11
L	Side drain with side port position	
*	Side drain with bottom port position	

Code	Drain port	12
IN/OUT GERMAN FLANGED PORTS		
Side	Rear	Type
TA	PLP 20	4-6,3-7,2-8-9-10,5-11,2
	PLM 20	24,5-25-27,8-31,5

IN/OUT EUROPEAN FLANGED PORTS		
Side	Rear	Type
GB	PLP 20	4-6,3-7,2-8-9-10,5-11,2
	PLM 20	24,5-25-27,8-31,5

IN/OUT SAE FLANGED PORTS (SSM)		
Side	Rear	Type
GB	PLP 20	4-6,3-7,2-8-9-10,5-11,2
	PLM20	24,5-25-27,8-31,5

IN/OUT SAE FLANGED PORTS (SSS)		
Side	Rear	Type
03	PLP 20	4-6,3-7,2-8-9-10,5-11,2
	PLM 20	24,5-25-27,8-31,5

IN/OUT GAS STRAIGHT THREAD PORTS (BSPP)		
Side	Rear	Type
GB	GB PLP 20	4-6,3-7,2-8-9-10,5-11,2
	PLM 20	24,5-25-27,8-31,5

IN/OUT SAE STRAIGHT THREAD PORTS (ODT)		
Side	Rear	Type
03	03 PLP 20	4-6,3-7,2-8-9-10,5-11,2
	PLM 20	24,5-25-27,8-31,5

Code	Shaft arrangement	13
FS	Female spline	

- (a) Choose the seals according to the temperature shown on page 4.
- (b) Mounting flange material on page 61 ÷ 65
Rear cover material on page 34 ÷ 35

02/07.2006

VERSIONS

For each version, the possible combination between drive shafts and mounting flanges are shown on pages 58 ÷ 68.

VERSION 0

Available for group:

10 20 30

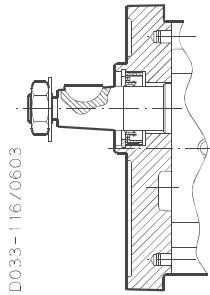

Version for applications without radial and axial load on the drive shaft.

VERSION W8

Available for group:

20

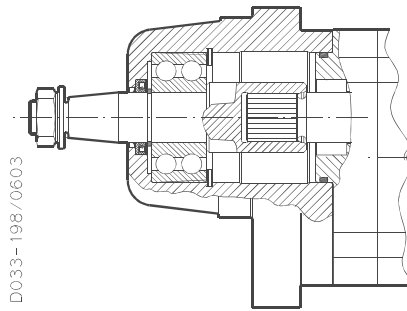

VERSION 4

Available for group:

20

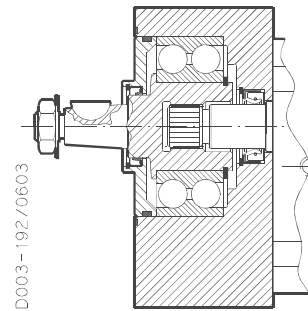

VERSION 5

Available for group:

20

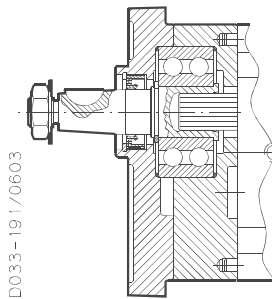

VERSION 6

Available for group:

20

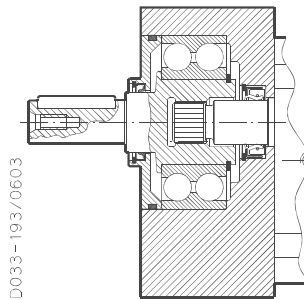

VERSION 7

Available for group:

20

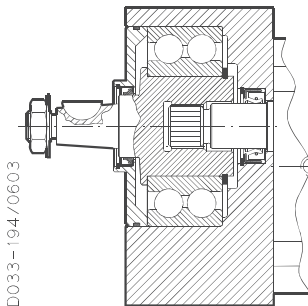

VERSION 8

Available for group:

20

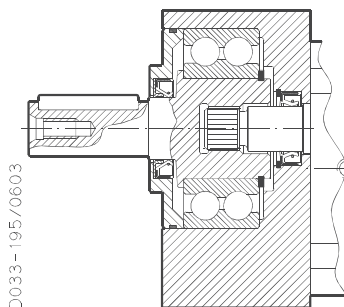

VERSION 9

Available for group:

20

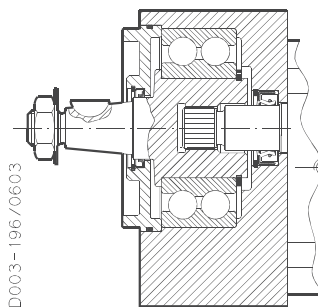

01/10.03

For the outboard bearing life expectancy, diagrams providing approximate selection data will be found on subsequent pages. For particular applications please consult our technical sales department.

POLARIS 20

DRIVE SHAFTS

EUROPEAN TAPERED 1:8

82

Not available with size:

20•10,5 20•24,5 20•27,8

Mounting face refer to flange code **E2**

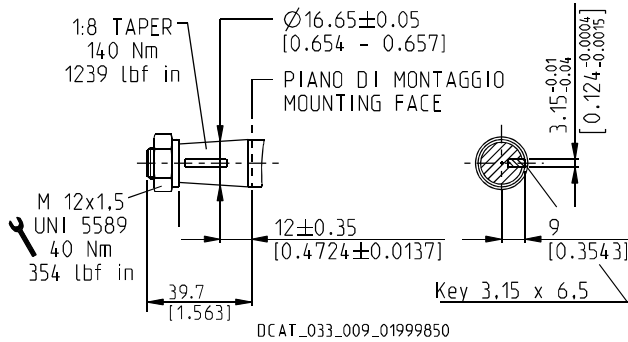

GERMAN TAPERED 1:5

54

Not available with size:

20•7,2 20•10,5 20•19 20•24,5 20•27,8 20•31,5

Mounting face refer to flange code **B2**

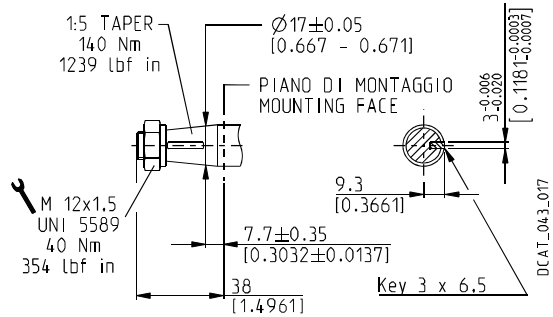

GERMAN TAPERED 1:5

55

Only for version **5, 9** and **W8** with outboard bearing

Mounting face refer to flange code **B2**

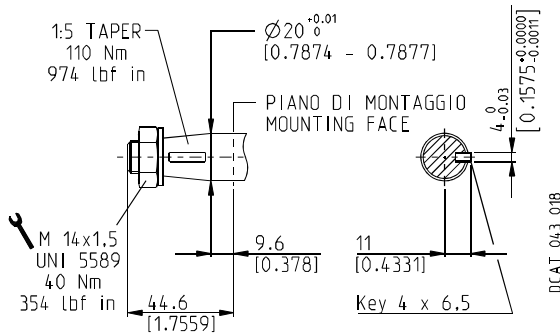

STRAIGHT

46

Not available with size:

20•7,2 20•10,5 20•19 20•24,5 20•25 20•27,8 20•31,5

Mounting face refer to flange code **E2**

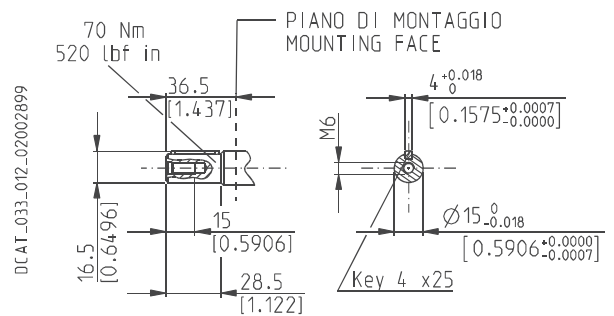

SAE "A" SPLINE

03

Not available with size:

20•24,5 20•27,8

Mounting face refer to flange code **S1**

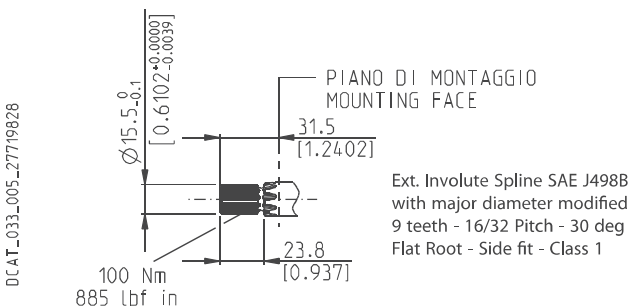

SPLINE

01

Not available with size:

20•6,3 20•9 20•10,5 20•19

Mounting face refer to flange code **S1**

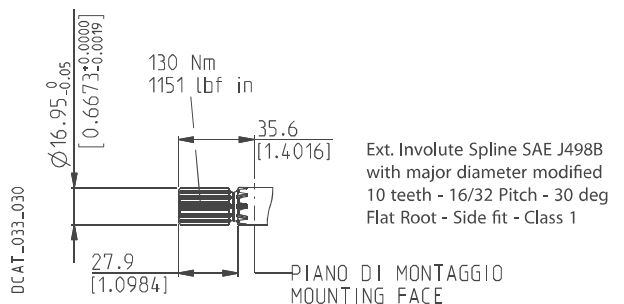

01/10.03

POLARIS 20

MOUNTING FLANGES AND TABLE OF COMPATIBILITY

Replaces: 01/10.03

EUROPEAN

E2

Material: cast iron and aluminium

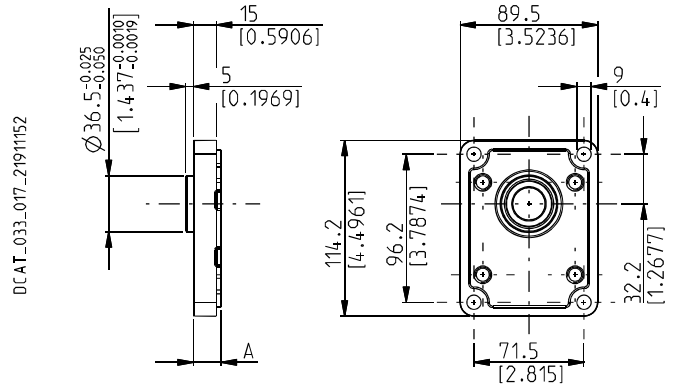

DRIVE SHAFTS

See page 53 ÷ 55

VERSIONS See page 47	A mm (in)	82	46	B1	03	04	07	12	31	48	49	50	54
0	18 (0.7087)	#	#		X	X	X	X	X	X	X	X	X
4	55,4 (2.1811)	#											
5	43,6 (1.7165)	#		X	X						X	X	X
6	55,4 (2.1811)									#			
7	59,4 (2.3386)	#											
8	59,4 (2.3386)			#									

Standard combination

X Available combination

GERMAN

B2

Material: cast iron and aluminium

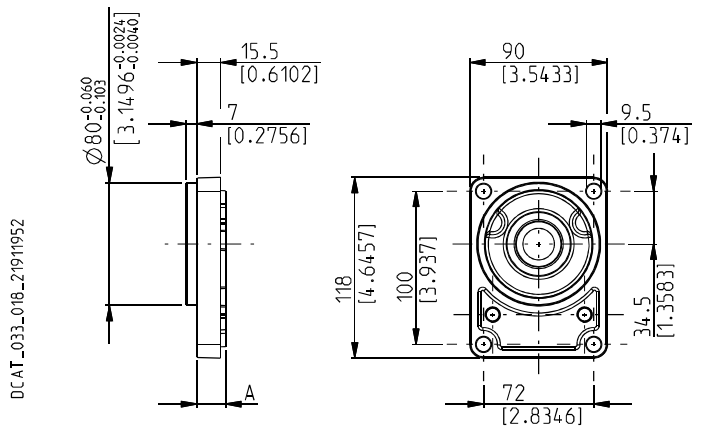

DRIVE SHAFTS

See page 53 ÷ 55

VERSIONS See page 47	A mm (in)	12	54	55	01	03	31	46	49	82
0	18,8 (0.7402)	#	#		X	X	X	X	X	X
5	44,4 (1.7480)		X	X		X			X	X
9	59,4 (1.7441)			X						

Standard combination

X Available combination

02/07.2006

PORTS SIZES

 Tightening torque for low pressure side port

 Tightening torque for high pressure side port [values obtained at 5075 psi (350 bar)]

For reversible rotation, please consult only the tightening torque for high pressure side port

Replaces: 01/10.03





GAS STRAIGHT THREAD PORTS

BSPP

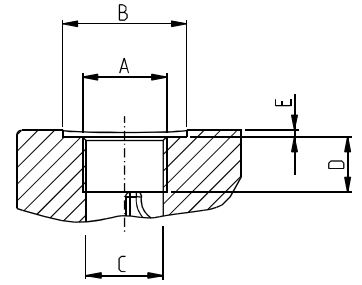
British standard pipe parallel (55°) conforms to UNI - ISO 228

DCAT_006_026_21064779



CODE	Nominal size	A	Ø B	Ø C	D	E		
			mm (in)	mm (in)	mm (in)	mm (in)	Nm (lbf in)	Nm (lbf in)
GC 	3/8"	G 3/8	30 (#) (1.1811)	15 (0.5906)	10 (#) (0.3937)	2 (#) (0.0787)	15 ⁺¹ (#) (133 ÷ 142)	—
			—		14 (0.5512)	—	15 ⁺¹ (133 ÷ 142)	25 ⁺¹ (221 ÷ 230)
GD 	1/2"	G 1/2	—	19 (0.7480)	14 (0.5512)	—	20 ⁺¹ (177 ÷ 186)	50 ^{+2.5} (443 ÷ 465)
			—	24,5 (0.9646)	18 (0.7087)	—	30 ^{+2.5} (266 ÷ 288)	90 ⁺⁵ (797 ÷ 841)
GE	3/4"	G 3/4	—	30,5 (1.2008)	18 (0.7086)	—	50 ^{+2.5} (443 ÷ 465)	130 ⁺¹⁰ (1151 ÷ 1239)
GF	1"	G 1	—	39 (1.5354)	22 (0.8661)	—	60 ⁺⁵ (531 ÷ 575)	170 ⁺¹⁰ (1505 ÷ 1593)
GG	1" 1/4	G 1 1/4	—	45 (1.7716)	24 (0.9448)	—	70 ⁺⁵ (620 ÷ 664)	210 ⁺¹⁵ (1859 ÷ 1992)
GH	1" 1/2	G 1 1/2	—			—		

(#) = Drain port

(◆) For POLARIS 20

02/07.2006