

SV3-10-C/CM/CR - Solenoid Valve

2-way, 2-position, normally closed, poppet type solenoid valve
 45 L/min (12 USgpm) • 210 bar (3000 psi)

A

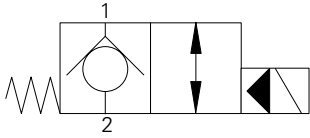

Operation

In the de-energized position the valve blocks flow from port 2 to 1 and free flow is allowed from port 1 to 2.

When the solenoid is energized the pilot poppet is pulled off the seat allowing the valve to open in both directions.

Features

Hardened and ground working parts. Lapped seat for low leakage. IP69K Tough coil compatibility. Continuously rated. Compact design with low pressure drop.

Sectional View

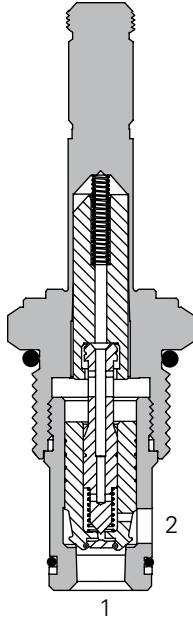

Performance Data

Ratings and Specifications

Performance data is typical with fluid at 21,8 cST (105 SUS) and 49°C (120°F)

Typical application pressure (all ports)	210 bar (3000 psi)
Cartridge fatigue pressure (infinite life)	210 bar (3000 psi)
Rated flow	45 L/min (12 USgpm)
Internal leakage	less than 5 drops/min, max @ 210 bar (3000 psi)
Temperature range	-40° to 120°C (-40° to 248°F)
Coil duty	Continuous from 85% to 110% of nominal voltage
Cavity	C-10-2
Fluids	All general purpose hydraulic fluids such as: MIL-H-5606, SAE 10, SAE 20 etc.
Filtration	Cleanliness code 18/16/13
Housing material (standard)	Aluminum
Weight cartridge only	0,4 kg (0.87 lbs)
Seal kit	565803 (Buna-N), 566086 (Viton®)

Viton is a registered trademark of E.I. DuPont

Description

This is a 2-way, 2-position, poppet type, pilot operated, normally closed solenoid valve. This valve is used in applications requiring low leakage, such as load holding applications or as a general purpose diverter or dump valve.

Pressure Drop Curves

Cartridge only

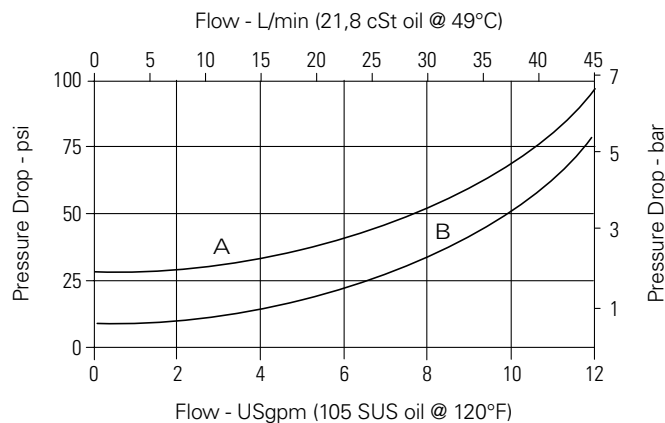

A - Port 1 to port 2 de-energized

B - Port 2 to port 1 energized

Where measurements are critical request certified drawings. We reserve the right to change specifications without notice.

SV3-10-C/CM/CR - Solenoid Valve

2-way, 2-position, normally closed, poppet type solenoid valve
45 L/min (12 USgpm) • 210 bar (3000 psi)

Model Code

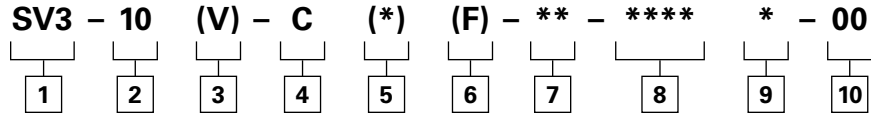

1 Function
SV3 - Solenoid valve

2 Size
10 - 10 size

3 Seal Material
Blank - Buna-N
V - Viton®

4 Style
C - Normally closed

5 Manual Override Option
Blank - No manual override
M - Knob type
R - Cable type
For valve dimensions with manual override option installed see page A-980.

6 Filter Options
Blank - None
F - Filter screen

Dimensions
mm (inch)

Cartridge Only

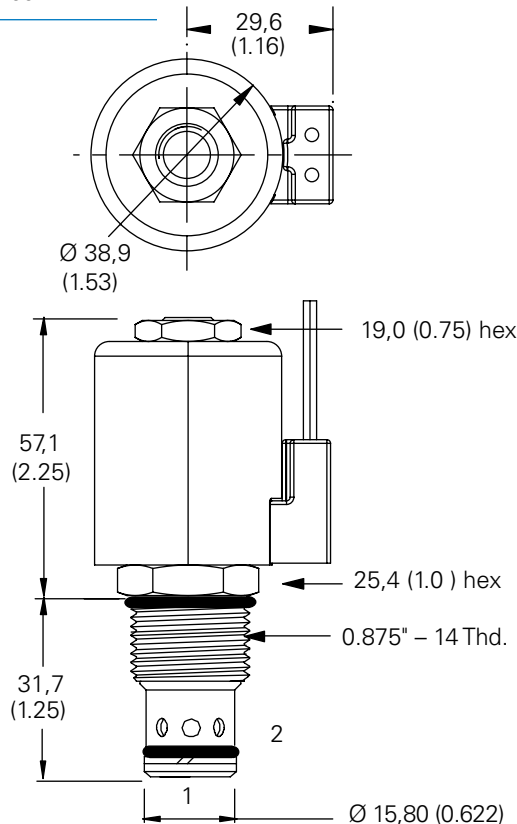

7 Port Size

Code	Port Size	Housing Number
0	Cartridge only	
3B	3/8" BSPP	02-175462*
2G	1/4" BSPP	876702
3G	3/8" BSPP	876703
6T	SAE 6	566151*
6H	SAE 6	876700
8H	SAE 8	876701

See section J for housing details.
*Light duty housing

8 Voltage Rating

00	No coil	24A - 24VAC
12D	12VDC	115A - 115VAC
24D	24VDC	230A - 230VAC
36D	36VDC	12B - 12VDC/w diode*
		24B - 24VDC/w diode*

*Optional arc suppression diode.

9 Connector Types
Blank - No coil
G - ISO 4400 DIN 43650
Q - Spade terminals
W - Flying lead
N - Deutsch (DC only)
Y - Amp JR (DC only)
D - Metripack 150 male (DC only)
J - Metripack 280 male (DC only)

For coil part numbers and dimensions see section C.

10 Special Features
00 - None
(Only required if valve has special features, omitted if "00.")

Torque cartridge in aluminum housing 47-54 Nm (35-40 ft lbs)

Note: When solenoid valve is ordered as cartridge only, coil nut is included.

Installation Drawing

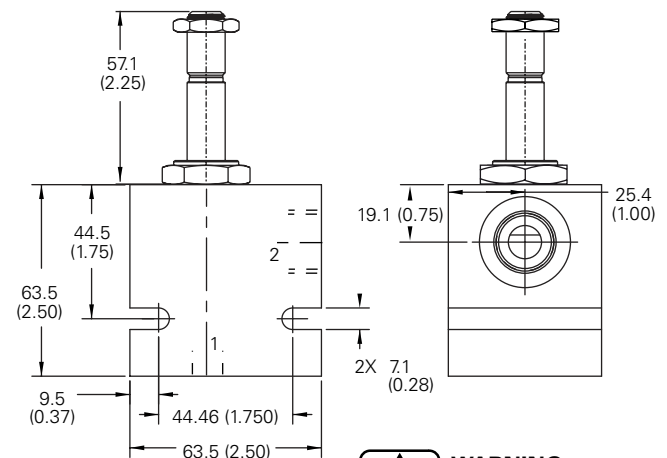

Note: Use J series, 23 W coils with this solenoid valve.

WARNING
Maintain 5-8 Nm (4-6 ft lbs) maximum torque on valve tube nut. Over tightening may cause valve failure.