



Torqmotor™

Series

TE / TJ / TF / TL / TG / TH / TK



parker.com/pmde



ENGINEERING YOUR SUCCESS.

Performance

Drehzahl Speed Vitesse de rotation Velocità di rotazione	max. 710 rev/min
Schluckstrom Oil flow Débit d'huile Portata	max. 115 l/min
Eingangsdruck Supply pressure Pression entrée Pressione in entrata	max. 300 bar
Torque Couple Coppia	max. 1490 Nm
Seitenlast Side load Charges latérales Carico radiale	max. 16.000 N See page 51

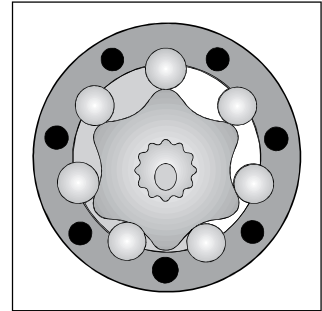
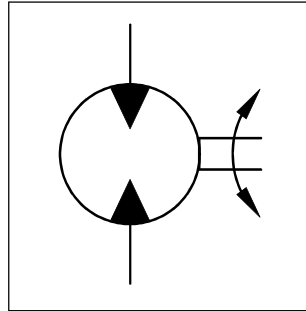

Motor series TG	Geom. Schluckvolumen Geometric displacement Cylindrée	Max. Drehzahl Max. speed Vitesse de rotation maxi Velocità di rotazione max	Max. Schluckstrom Max. oil flow Débit d'huile max Portata max	Max. Druckdifferenz ** Max. differential pressure ** Chute de pression maxi ** Caduta di pressione max **	Max. Eingangsdruck Max. supply pressure Pression maxi entrée Pressione max in entrata	Max. Drehmoment Max. torque Couple maxi Coppia max	Max. Leistungsabgabe Max. performance Puissance de sortie max Potenza meccanica max	Min. Anlaufmoment Min. starting torque Couple min. fourni au démarrage Coppia min. di spunto
	[cm ³ /U] [cm ³ /rev]	cont / int* [U/min] [rev/min]	cont / int* [l/min]	cont / int* [bar]	max [bar]	cont / int* [Nm]	cont / int* [KW]	cont / int* [Nm]
TG 140	141	530/710	75/100	210/280	300	400/545	33	320/436
TG 170	169	440/575	75/100	210/280	300	485/670	33	388/536
TG 195	195	380/510	75/100	210/280	300	560/770	33	448/616
TG 240	238	320/420	75/100	210/280	300	685/945	32	548/756
TG 280	280	270/350	75/100	210/280	300	800/1100	31	675/880
TG 335	337	225/290	75/100	210/280	300	980/1350	30	784/1080
TG 405	405	185/245	75/100	170/240	300	960/1350	27	791/1145
TG 475	477	160/240	75/115	140/210	300	960/1400	28	768/1120
TG 530	529	140/215	75/115	140/170	300	1050/1280	23	874/1091
TG 625	613	120/185	75/115	120/160	300	1040/1360	20	895/1165
TG 785	786	95/145	75/115	100/140	300	1150/1490	17	991/1341
TG 960	959	78/119	75/115	70/100	300	925/1390	12	763/1177

*int. =
Intermittierende Werte maximal: 10% von jeder Betriebsminute.
Intermittent operation rating applies to 10% of every minute.
Fonctionnement interm.: 10% max. de chaque minute d'utilisation.
Servizio intermittente: 10% max di ogni minuto di utilizzazione.

** Druckdifferenz Δp zwischen Ein- und Ausgang
** Pressure difference is Δp between input and output
** La différence de pression est Δp entre l'entrée et la sortie
** La differenza di pressione corrisponde al Δp tra ingresso e uscita

Code H

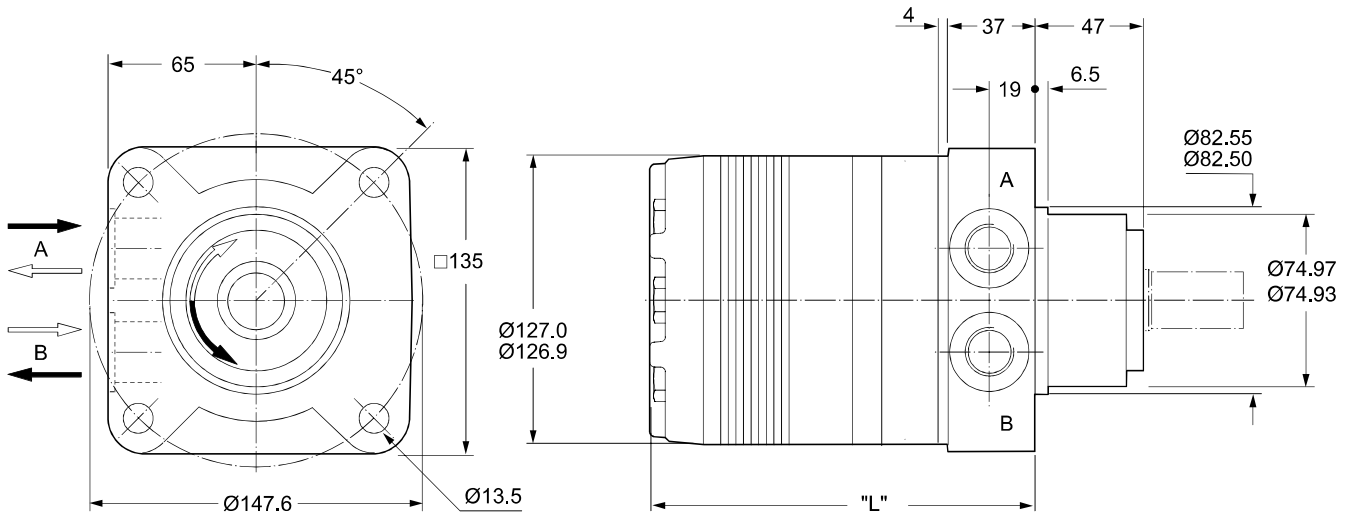

Code V

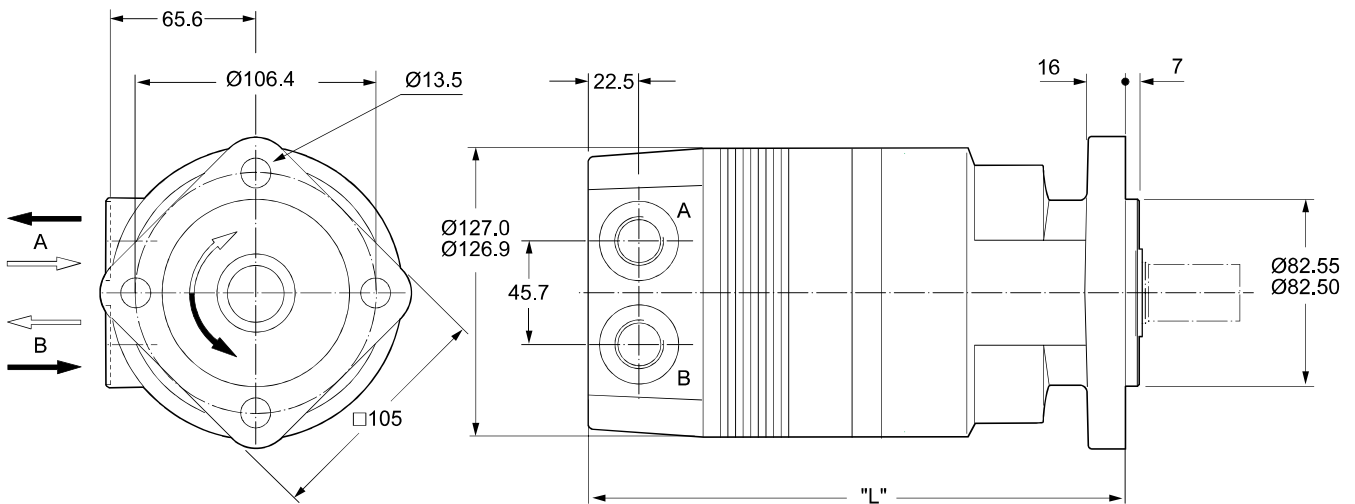

Gewicht / Weight	TG140	TG170	TG195	TG240	TG280	TG335	TG405	TG475	TG530	TG625	TG785	TG960
Poids / Peso [kg]	16.1	16.3	16.6	17.0	17.4	17.8	18.4	19.0	19.8	20.5	22.0	23.7
Code H "L" [mm]	150	154	157	162	166	173	180	188	195	204	223	242
Code V "L" [mm]	217	220	224	228	233	238	246	255	262	272	290	309

Code W

G1/2 x 15

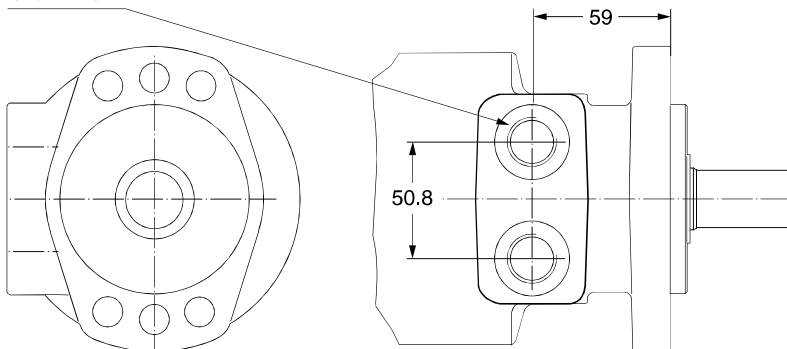

Code: N

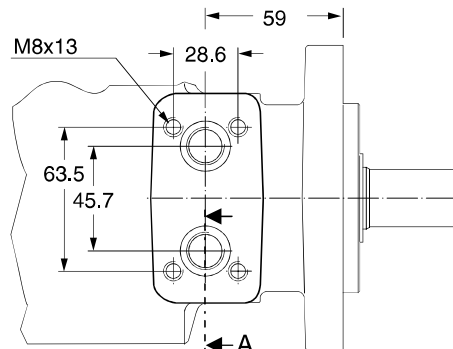

Code W

G1/2 x 15

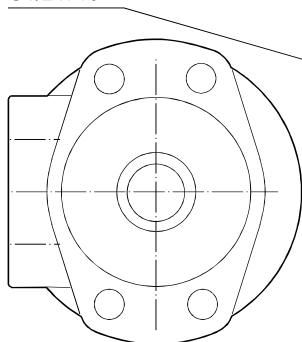

Code V

7/8-14UNF,
 O-Ring

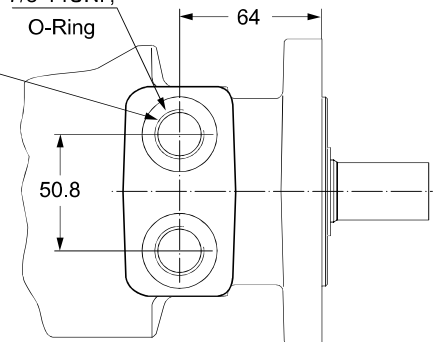

Code N

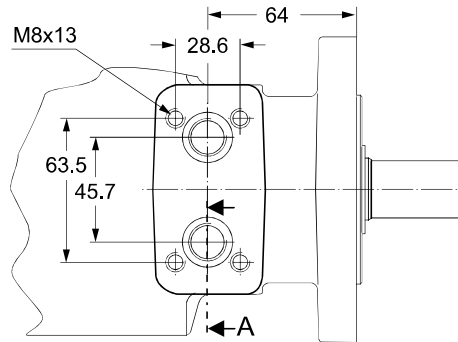

Code W

G1/2 x 15

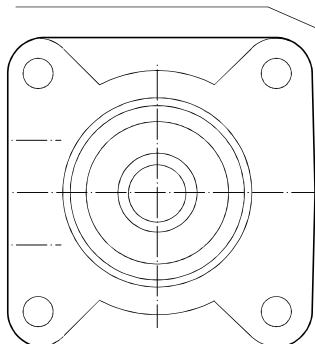

Code V

7/8-14UNF,
 O-Ring

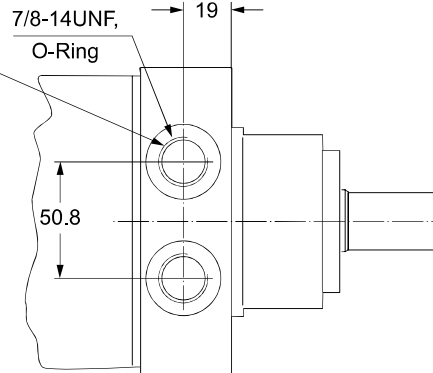

Code K

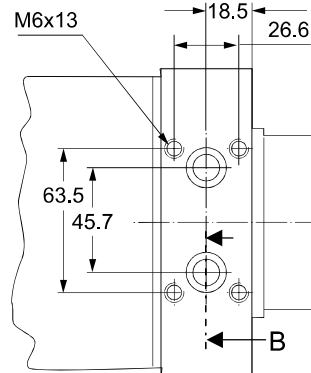

Section A

O-Ring Ø18x2 NBR 80

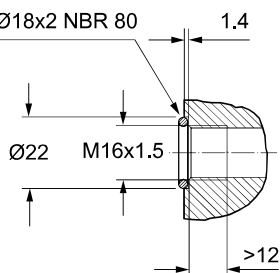

Section B

O-Ring Ø12.37x2.62
 ARP 568 no. 112

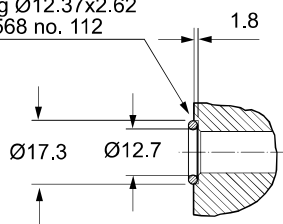

Zum Motor mit Universalanschluss werden 2 O-Ringe geliefert.

Motor with manifold mount is supplied with 2 O-rings.

Deux joints toriques sont livrés avec les moteurs au plan de raccordement universel.

Il blocchetto connessioni è corredato da 2 OR.

Code 44

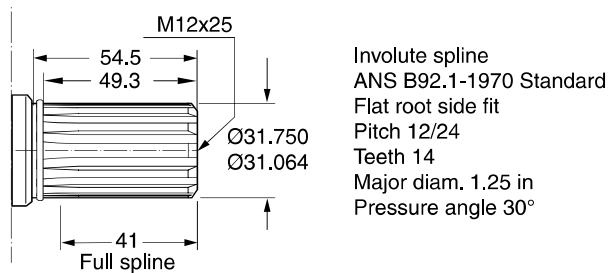

Code 45

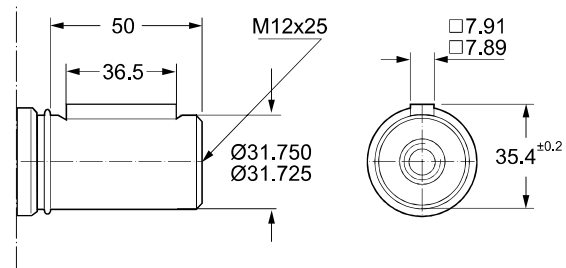

Code 08

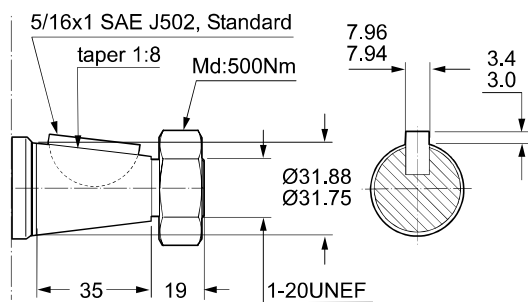

Code 46

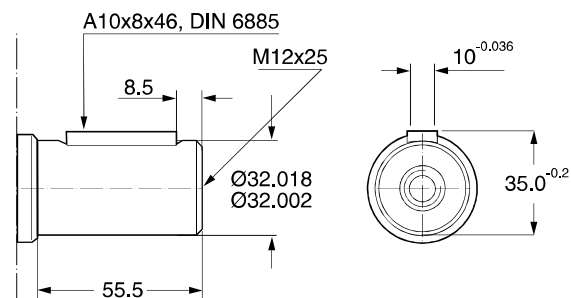

* On request shaft with 35mm diameter

Code 92

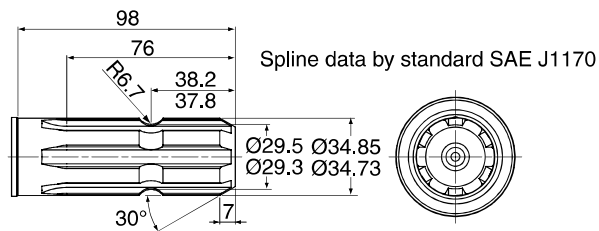

Code 94

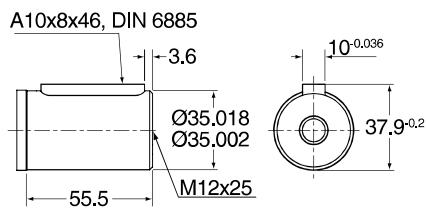

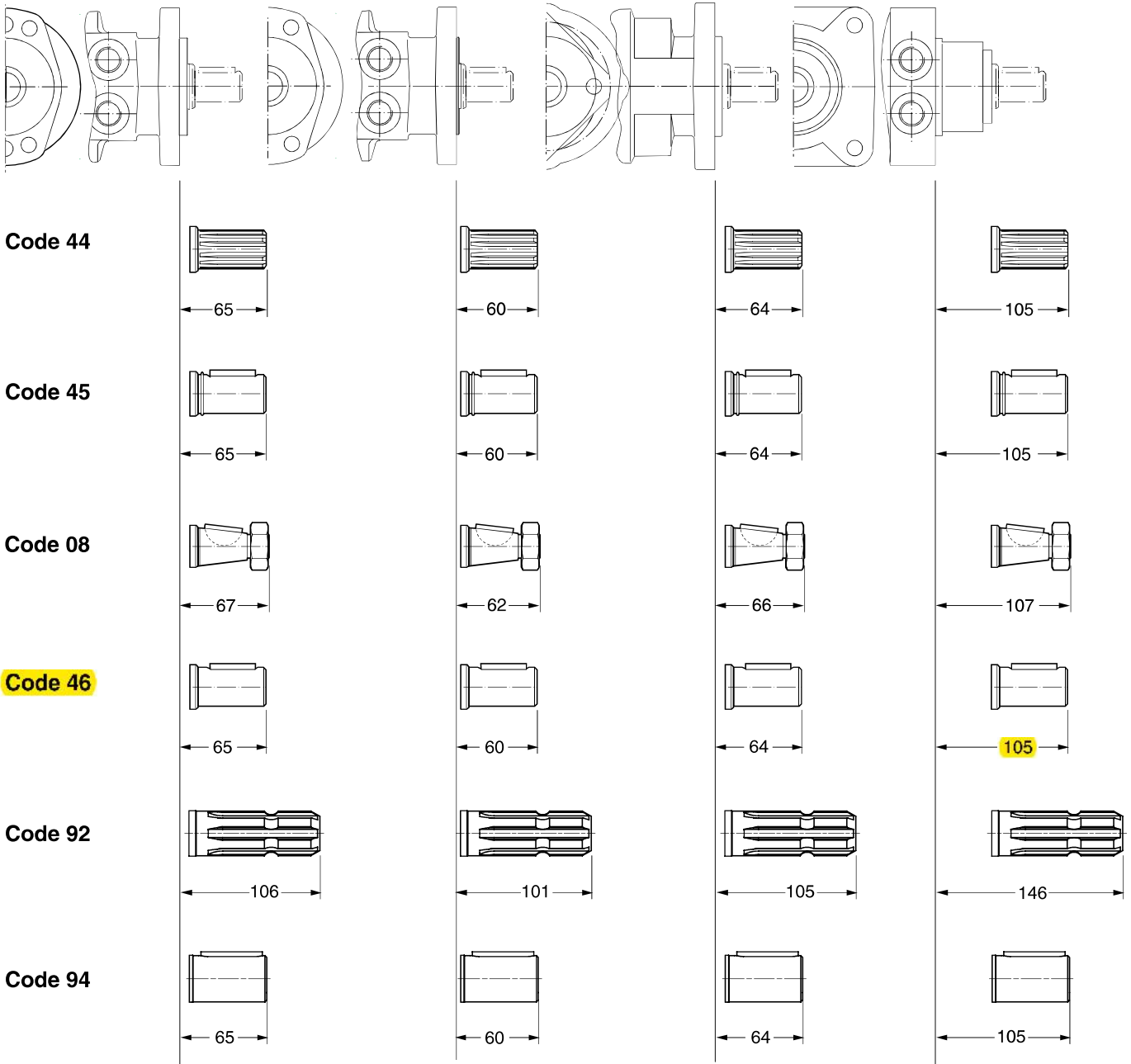

TG 405

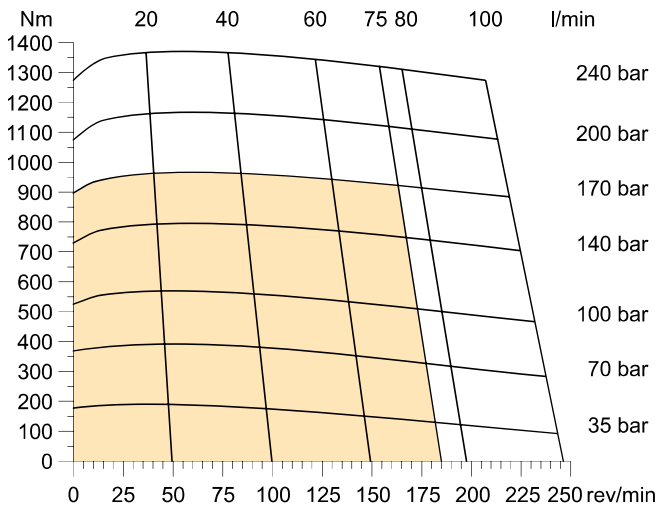

TG 475

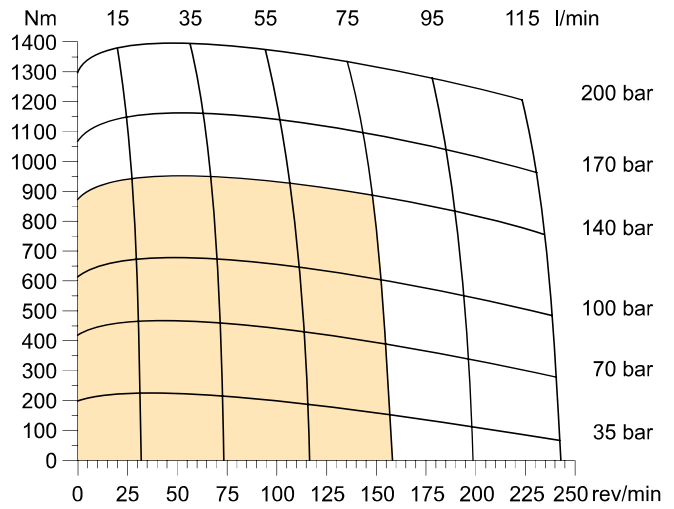

TG 530

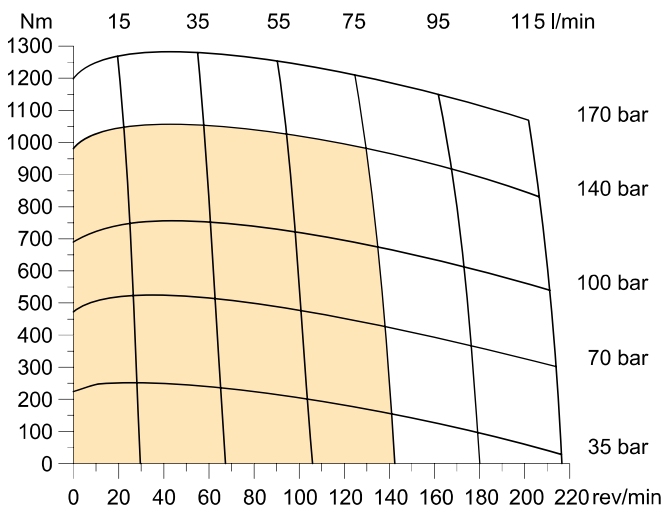

TG 625

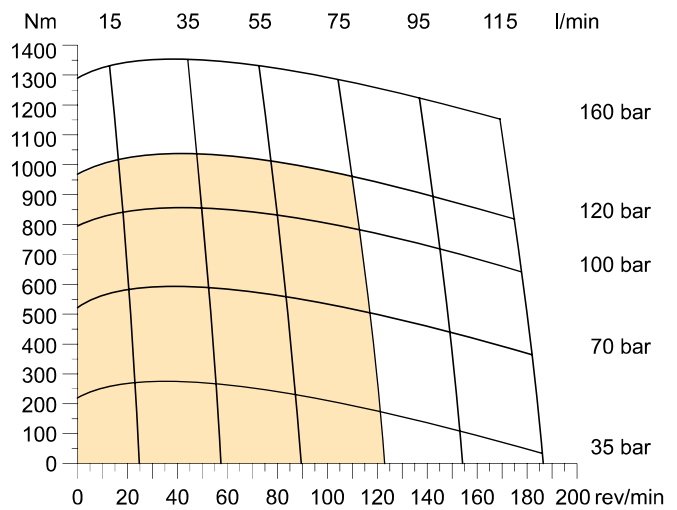

TG 785

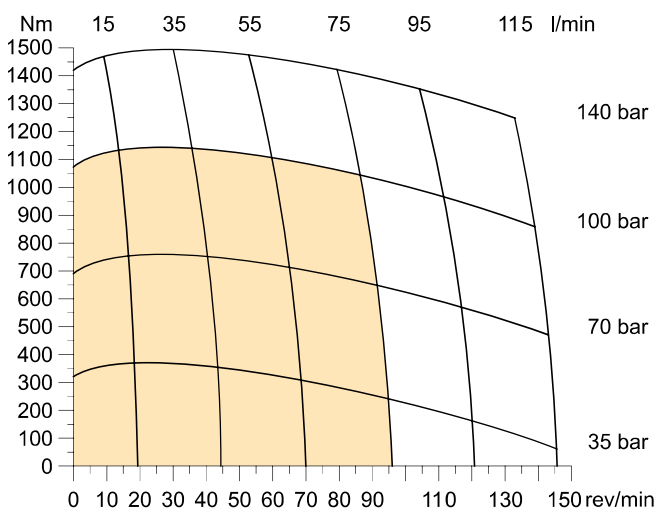

TG 960

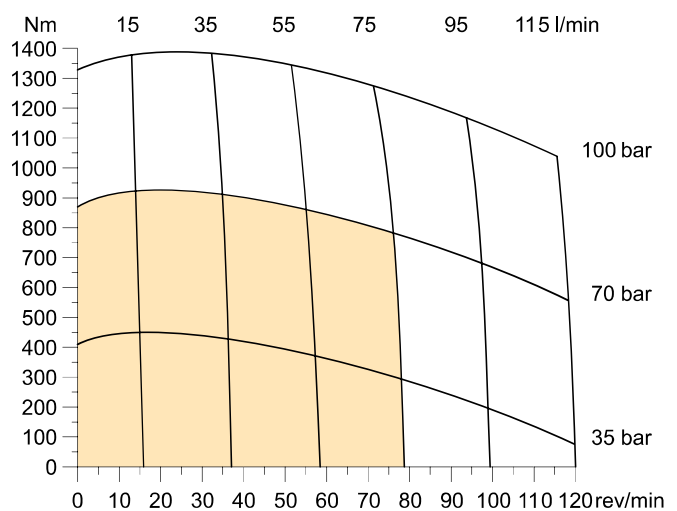

■ Cont. □ Int.

int. =
Intermittierende Werte maximal: 10% von jeder Betriebsminute.
Intermittent operation rating applies to 10% of every minute.
Fonctionnement interm.: 10% max. de chaque minute d'utilisation.
Servizio intermittente: 10% max di ogni minuto di utilizzazione.

Code E

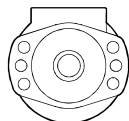

$$L_h = \frac{\left(\frac{670000}{F_R \cdot \left(1.10 + \frac{L}{88\text{mm}} \right)} \right)^{3.3}}{n}$$

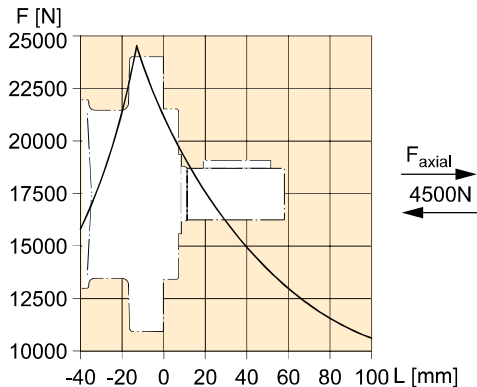

Code M

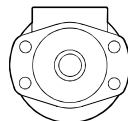

$$L_h = \frac{\left(\frac{670000}{F_R \cdot \left(1.16 + \frac{L}{88\text{mm}} \right)} \right)^{3.3}}{n}$$

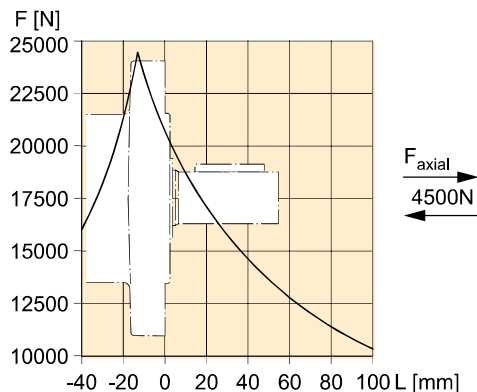

Code H

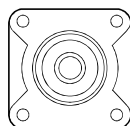

$$L_h = \frac{\left(\frac{670000}{F_R \cdot \left(0.56 + \frac{L}{88\text{mm}} \right)} \right)^{3.3}}{n}$$

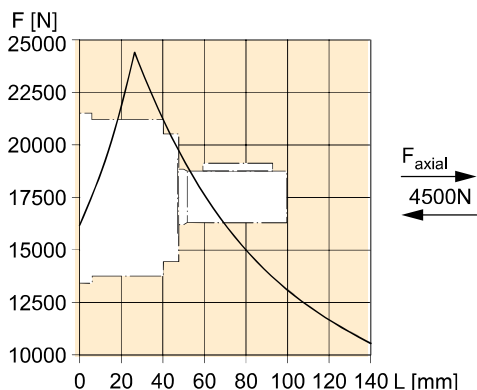

Code V

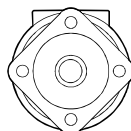

$$L_h = \frac{\left(\frac{670000}{F_R \cdot \left(1.11 + \frac{L}{88\text{mm}} \right)} \right)^{3.3}}{n}$$

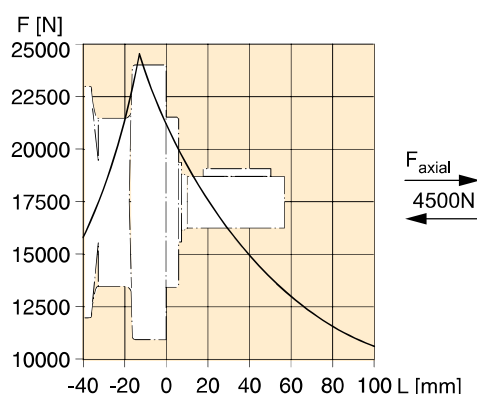

Die Lebensdauer der Radiallager (L_h in Stunden) lässt sich nach folgender Formel berechnen. Die Größe F_R ist durch die mechanische Festigkeit der Abtriebswelle begrenzt (siehe Diagramm). Das Maß "L" ist das Längenmaß vom Gehäuseflansch bis zum Angriffspunkt der Radialkraft F_R .

La durée de vie des roulements radiaux (L_h en heures) peut être calculée par les formules suivantes. La grandeur F_R est limitée par les résistances mécaniques de l'arbre de sortie (voir diagramme). La cote "L" est la longueur entre la bride du carter jusqu'à un point d'appui de l'effort radial F_R .

Life time (L_h in hours) of the radial bearings can be calculated with the following formula. The value F_R is limited by the mechanical strength of the shaft (see diagram). The measurement "L" is the length from the housing flange up to the point of impact of the radial force F_R .

La durata dei cuscinetti (L_h in ore) può essere calcolata con la seguente formula. Il valore F_R è limitato dalla resistenza meccanica dell'albero (vedi diagramma). La quota "L" è la distanza tra la flangia del corpo ed il punto di applicazione della forza radiale F_R .

Vorstehende Formeln gelten für eine B10-Lebensdauer.
 The preceding formulas are valid for a B10 duration of life.
 Les formules précédentes sont valables pour une durée de vie B10.
 Le formule precedenti sono valide per una durata della vita B10.

L_h = [h]
 L = [mm]
 F_R = F [N]
 n = [rev/min]

