

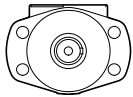

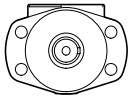

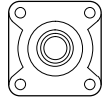



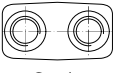
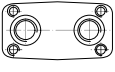
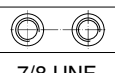

Pos. 1				
Gehäuse komplett Housing assembly Carter Scatola motore				
 G 1/2	ME012015J3 CODE EW	ME012041J3 CODE MW	ME012032J3 CODE HW	-----
 Universal	ME012037J3 CODE EN	ME012039J3 CODE MN	ME012030J3 CODE HK	-----
 7/8 UNF	ME012034J3 CODE EV	ME012038J3 CODE MV	ME012042J3 CODE HV	-----
Endanschluss Rear port Orifices arrière Alim. laterale	ME012036J3 CODE E*	ME012004J3 CODE M*	ME012055J3 CODE H*	ME012049J3 CODE V*

Pos. 2			Pos. 14	
Abtriebswelle / Coupling shaft Arbre / Albero uscita			Passfeder / Key Clavette / Chiavetta	Scheibenfeder Woodruff key Clavette / Chiavetta
	Ø 25.00	MB019017 CODE 26	52510700	-----
	Ø 25.40	MB019014 CODE 47	-----	G124553
	6B SAE	MB019013 CODE 41	-----	-----
	Ø 31.75	<b>MB019015</b> <b>CODE 45</b>	52530507	-----
	1:8 1.25 inch	MB019000 CODE 08	-----	G124554
	Ø 32.00	MB019016 CODE 46	039044	-----
	12/24 pitch 14 teeth	MB019024 CODE 44	-----	-----

	Pos. 3		Pos. 4	Pos. 5
Baugröße Size Taille Grandezza	Schraube / Bolt Vis / Vite	Für Endanschluss For rear port Pour orifices arrière Per alimentazione laterale	Rotor komplett Rotor set Jeu rotor Rotore	Zwischenwelle Drive link Abre d'entrain Albero entrata
80	021271	021386	MB057003	MB063000
100	021271	021386	MB067003	MB063000
130	021271	021273	MB087003	MB083000
140	021390	021273	MB097003	MB093000
170	021376	021387	MB107003	MB103000
195	021352	021379	MB127003	MB123000
240	021272	021291	MB157003	MB153000
280	021340	021392	MB187003	MB183000
360	021387	021366	ME237003	ME233000
405	021379	021415	ME247003	ME243000
475	021392	021394	ME297003	ME293000

Pos. 6	
Dichtsatz komplett Seal kit Jeu de joints Kit guarnizioni	SK000092

Pos. 8	
Axiallager Thrust bearing Roulement Cuscinetto reggispinta	068024

Pos. 9	
Zwischenscheibe Wear plate Plaque d'usure Piastra d'usura	477342

Pos. 10		
Verteiler Manifold Plan de pose Distributore	ME015000 Standard	CODE 0
Verteiler Manifold Plan de pose Distributore	ME015001 Reverse	CODE 1

Pos. 12	
Kommutator komplett Commutator assembly Ensemble commutateur Assieme distributore	MF018000A1
Für Endanschluss For rear port Pour orifices arrière Per alimentazione laterale	MF018001A1

Pos. 13		
Abschlussplatte / End cover Couvercle / Coperchio posteriore ME016000 Standard		
Für Endanschluss / For rear port Pour orifices arrière Per alimentazione laterale		
ME016009	7/8-14 UNF Axial	CODE A
ME016002	7/8-14 UNF Radial	CODE B
ME016007	Universal	CODE L
ME016010	G 1/2 Radial	CODE X
ME016011	G 1/2 Axial	CODE Y

Pos. 15	
Selbstsichernde Mutter Self-locking nut Ecrou nyl-stop Dado autobloccante	025126
Kronenmutter Castle nut Ecrou crénelé Tuerca	025132

Pos. 16	
Wellenring Circlip Circlips Anello seeger	401333

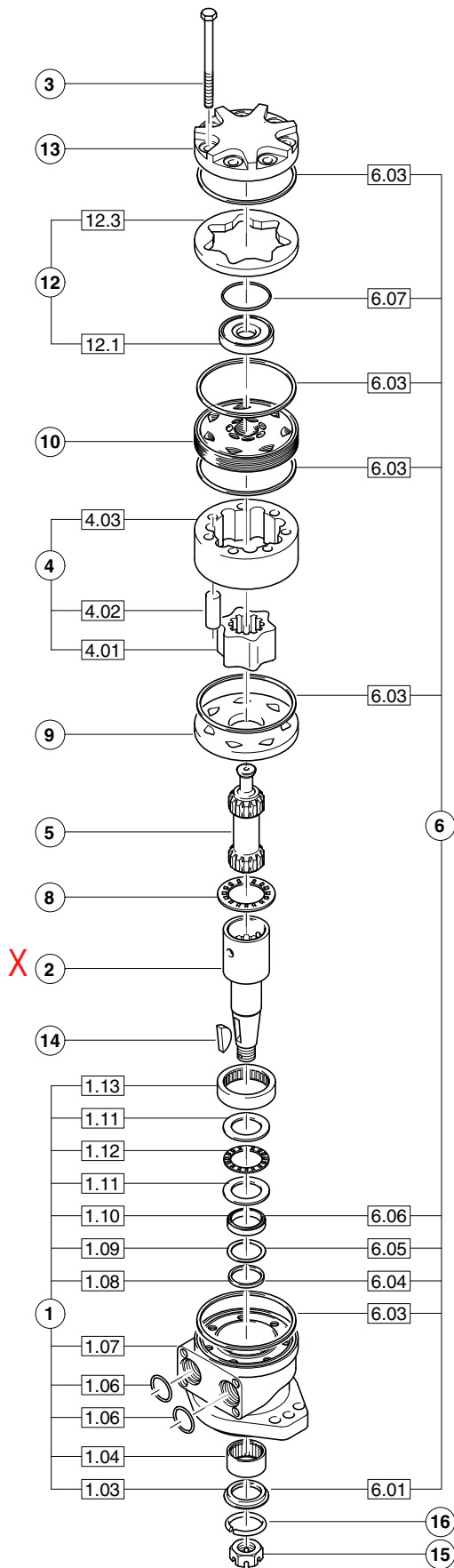

61...75Nm Anziehmoment wechselseitig an 7 Schrauben.

61...75Nm torque max. 7 bolts crosswise.

61...75Nm couple moteur max. 7 boulons réciproquement.

61...75Nm coppia di serraggio 7 bulloni.

Kommutator komplett mit neuer Dichtung einsetzen. Die flache Seite der Dichtung zeigt nach außen.

Fit commutator assembly with new seals. Assemble seal flat side out.

Remonter l'ensemble commutateur avec un nouveau joint côté plat à l'extérieur.

Montare il distributore con la nuova guarnizione con il lato piano verso l'esterno.

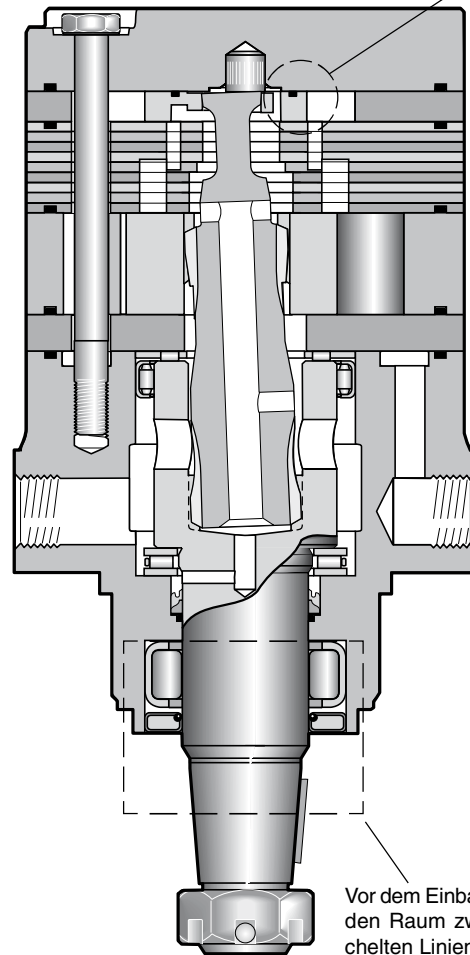
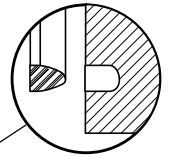

Vor dem Einbau der Abtriebswelle den Raum zwischen den gestrichelten Linien be fetten.

Apply grease to shaft OD. and ID. in area designated by dotted lines.

Avant l'assemblage de l'arbre veuillez graisser l'espace situé entre les lignes en tirets.

Prima del montaggio dell'albero pregasi lubrificare la zona evidenziata con linee tratteggiate.