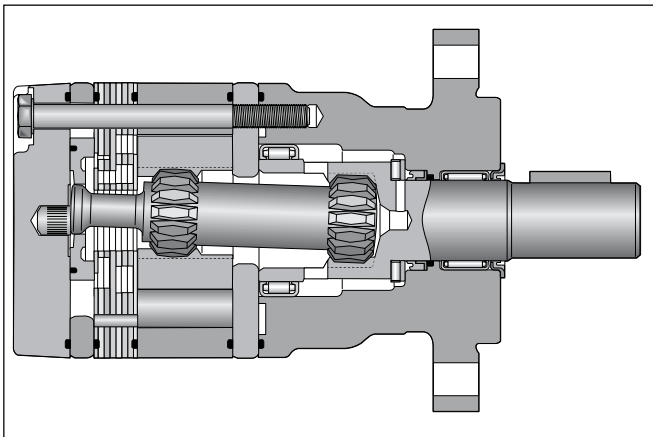
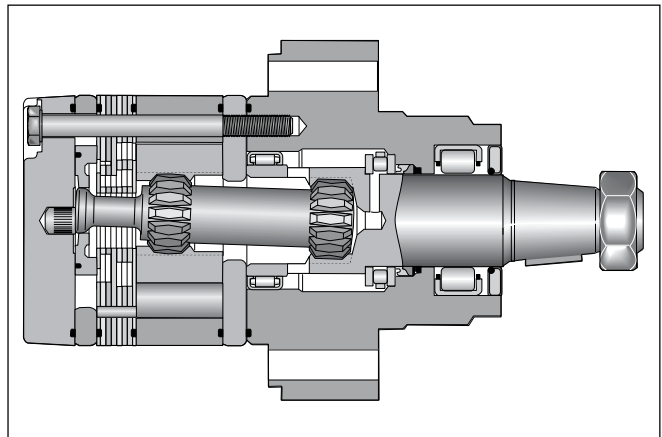

Features

- **Langsamlaufender Gerotor-Motor**
- **Spezielle Orbital-Steuerung**
Geringe interne Leakage
Hoher volumetrischer Wirkungsgrad
- **Rollen im Rotorsatz**
Reduzierte Reibung
Lange Lebensdauer
- **Patentierte Hochdruckwellendichtung**
Keine Leckölleitung
Keine Rückschlagventile
- **Vielzahl von Varianten**
Großer Einsatzbereich

Torqmotor**Series TE-TJ**

- **Low Speed Gerotor Motor**
- **Zero leak commutation valve**
For greater, more consistent
Volumetric efficiency
- **Roller vane rotor set**
Reduces friction and internal leakage
Maintaining efficiency throughout the life of the motor
- **Patented high-pressure shaft seal**
No check valves needed
No extra plumbing
- **Wide choice of displacement range, flange and shaft options**
Greater efficiency in systems design
to suit your application

Series TE**Series TJ**

- **Moteur lent système Gerotor**
- **Une distribution orbitale particulière assure**
fuites internes minimales
rendements volumétriques élevés
- **Le rotor à rouleaux**
réduit les frottements
augmente la durée de vie
- **Par l'utilisation de joints d'arbre haute pression brevetés**
pas de conduite de drainage
pas de clapets anti-retour
- **Grâce à de nombreuses variantes**
larges domaines d'applications

- **Motore orbitale a bassa velocità**
- **Una particolare distribuzione orbitale assicura**
trafilamento ridotto elevato rendimento volumetrico
- **Con lo statore a rullo**
si riduce l'attrito interno
si mantiene nel tempo l'efficienza del motore
- **Una guarnizione di tenuta ad alta pressione brevettata elimina la necessità**
di una linea di drenaggio esterna e di valvole non ritorno
- **Un'ampia gamma di cilindrate, flangiature ed alberi**
consentono scelte adeguate ad ogni esigenza costruttiva

Performance

Drehzahl Speed Vitesse de rotation Velocità di rotazione	max. 1160 rev/min
Schluckstrom Oil flow Débit d'huile Portata	max. 75 l/min
Eingangsdruck Supply pressure Pression entrée Pressione in entrata	max. 200 bar
Torque Couple Coppia	max. 648 Nm
Seitenlast Side load Charges latérales Carico radiale	TE = 7.000 N TJ = 14.000 N See page 16

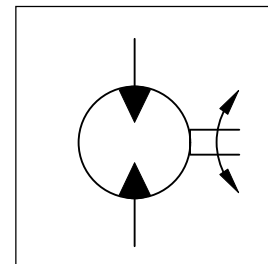
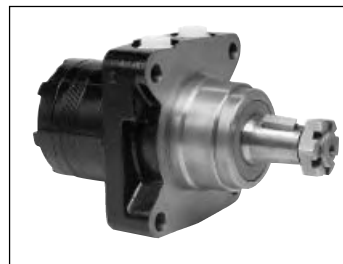

Series TJ



Series TE

Motor series TE / TJ	Geom. Schluckvolumen Geometric displacement Cylindrée Cilindrata	Max. Drehzahl Max. speed Vitesse de rotation maxi Velocità di rotazione maxi	Max. Schluckstrom Max. oil flow Débit d'huile max Portata max	Max. Druckdifferenz ** Max. differential pressure ** Chute de pression maxi ** Caduta di pressione max **	Max. Eingangsdruck Max. supply pressure Pression maxi entrée Pressione max in entrata	Max. Drehmoment Max. torque Couple maxi Coppia max	Max. Leistungabgabe Max. performance Puissance de sortie maxi Potenza meccanica max	Min. Anlaufmoment Min. starting torque Couple min. fourni Coppia min. di spunto
	[cm ³ /U] [cm ³ /rev]	cont / int* [U/min] [rev/min]	cont / int* [l/min]	cont / int* [bar]	max [bar]	cont / int* [Nm]	cont / int* [KW]	cont / int* [Nm]
TE/TJ 36	36	930/1160	35/40	140/190	200	55/71	9	44/52
TE/TJ 45	41	810/1024	35/41	140/190	200	70/100	10	44/64
TE/TJ 50	50	725/1020	35/50	140/190	200	90/127	13	72/98
TE/TJ 65	66	705/940	45/60	140/190	200	125/176	15	100/137
TE/TJ 80	82	560/750	45/60	140/190	200	160/220	17	128/171
TE/TJ 100	98	470/630	45/60	140/190	200	190/264	17	152/205
TE/TJ 130	130	350/470	45/60	140/190	200	255/352	17	204/274
TE/TJ 165	163	280/375	45/60	140/190	200	310/436	17	248/338
TE/TJ 195	196	235/315	45/60	140/190	200	390/528	17	312/411
TE/TJ 230	228	265/330	60/75	120/165	200	380/514	18	304/411
TE/TJ 260	261	230/290	60/75	110/155	200	400/550	17	320/449
TE/TJ 295	293	200/255	60/75	100/145	200	428/582	16	328/445
TE/TJ 330	326	185/235	60/75	100/135	200	443/600	15	344/453
TE/TJ 365	370	150/200	60/75	95/125	200	467/648	14	373/477
TE/TJ 390	392	152/190	60/75	85/120	200	445/628	13	348/462

*int. = Intermittierende Werte maximal: 10% von jeder Betriebsminute.
Intermittent operation rating applies to 10% of every minute.
Fonctionnement interm.: 10% max. de chaque minute d'utilisation.
Servizio intermittente: 10% max di ogni minuto di utilizzazione.

** Druckdifferenz Δp zwischen Ein- und Ausgang
** Pressure difference is Δp between input and output
** La différence de pression est Δp entre l'entrée et la sortie
** La differenza di pressione corrisponde al Δp tra ingresso e uscita

Code C

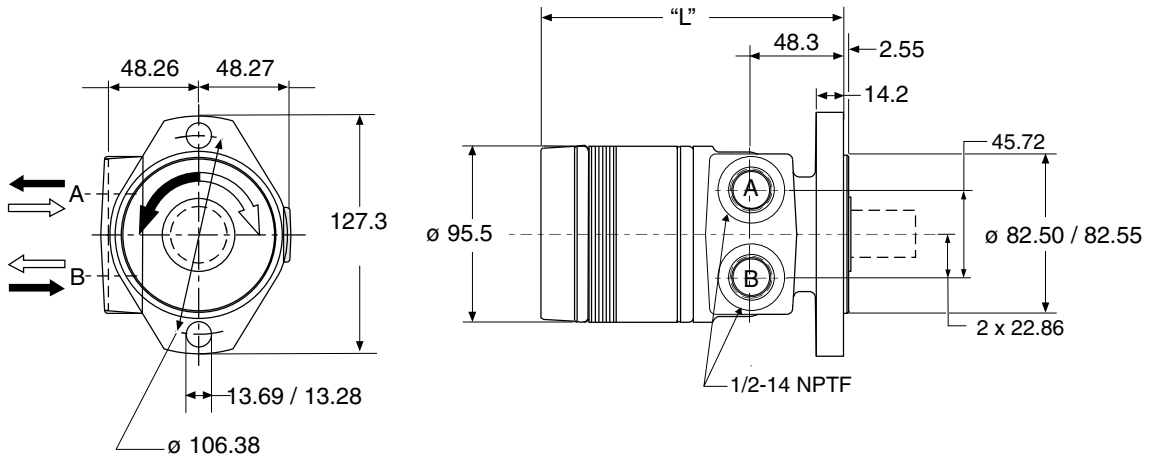

Code M

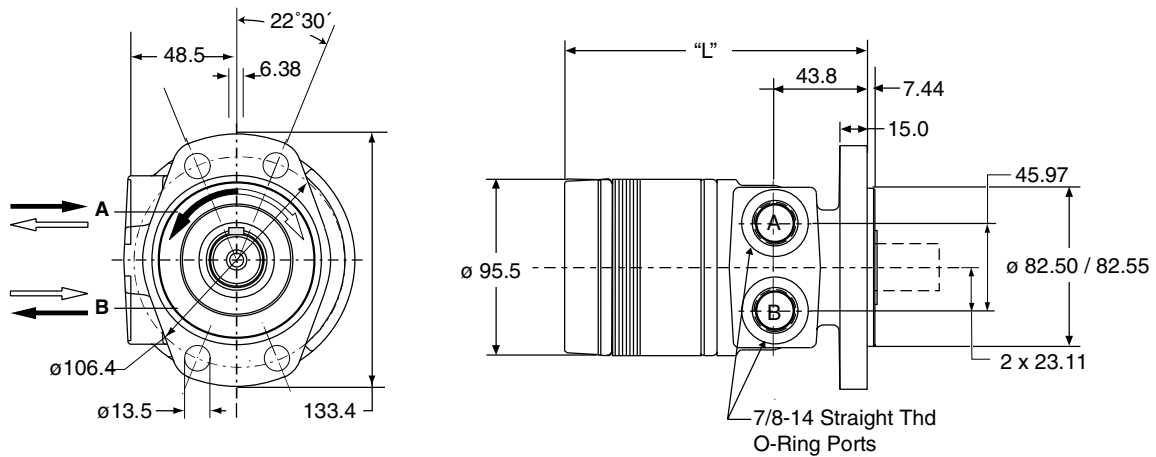

Code D

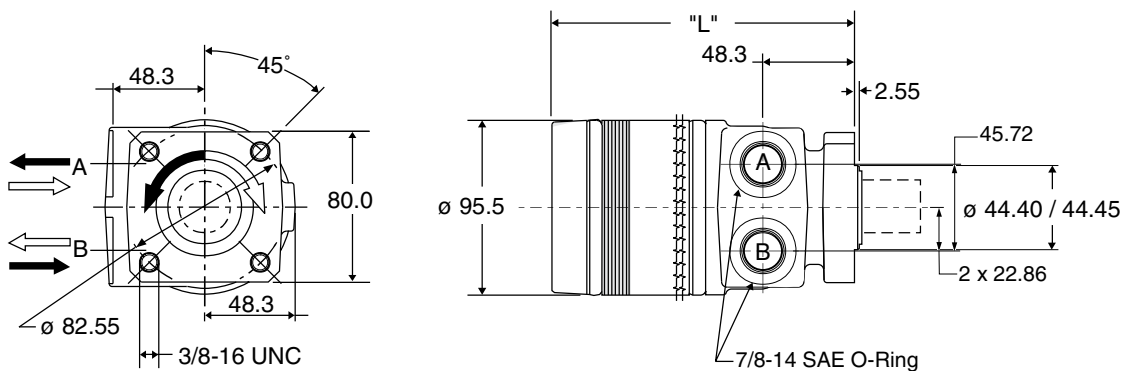

Gewicht / Weight Poids / Peso [kg]	TE36	TE45	TE50	TE65	TE80	TE100	TE130	TE165	TE195	TE230	TE260	TE295	TE330	TE365	TE390
Code C	128	131	133	136	140	143	149	155	162	168	174	181	187	195	200
Code M, D	134	136	138	141	144	147	153	160	166	173	179	185	192	200	205

Code W

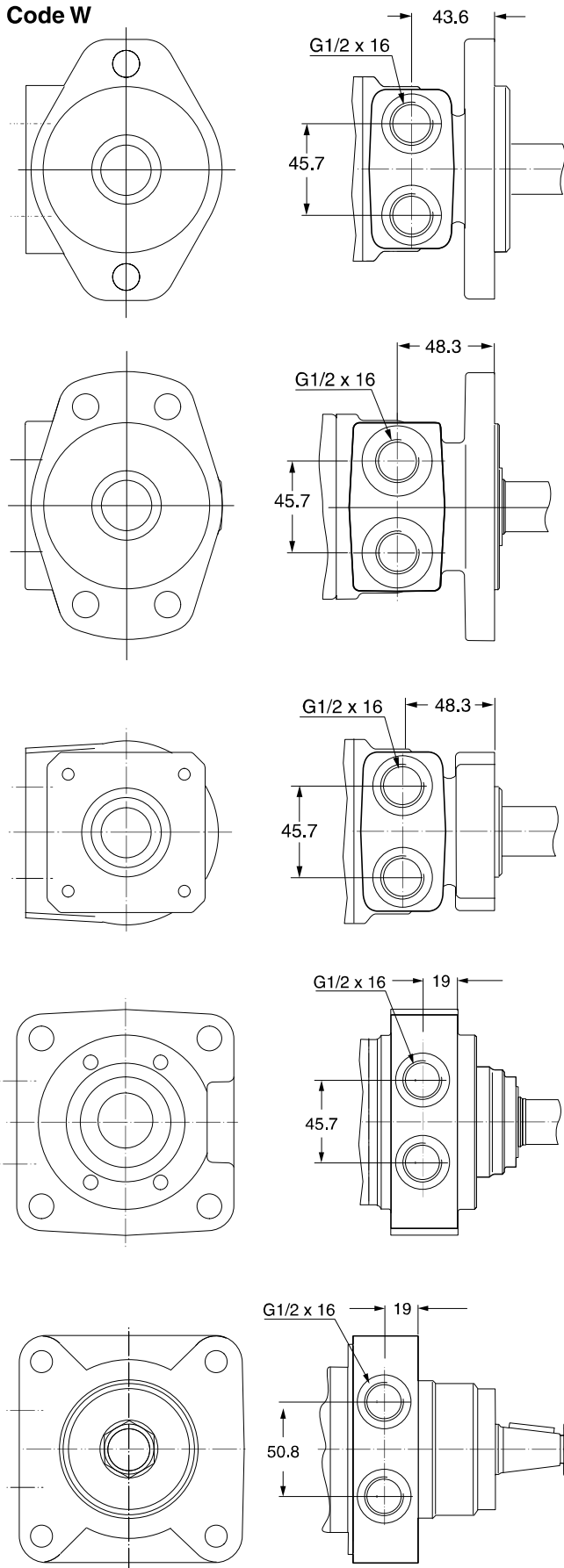

Code N

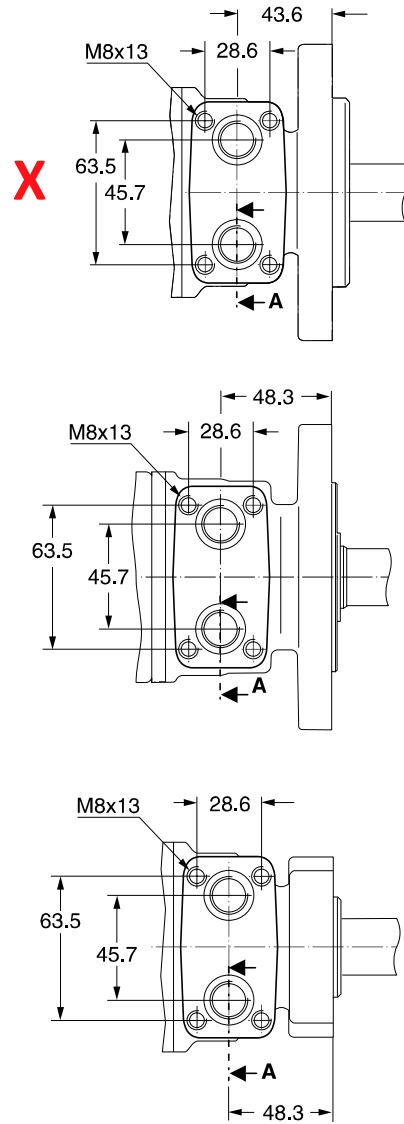

Section A

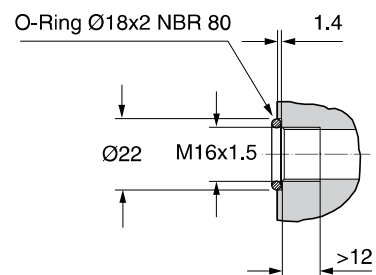

Zum Motor mit Universalanschluss werden 2 O-Ringe geliefert.

Motor with manifold mount is supplied with 2 O-rings.

Deux joints toriques sont livrés avec les moteurs au plan de raccordement universel.

Il blocchetto connessioni è corredato da 2 OR.

Code 08

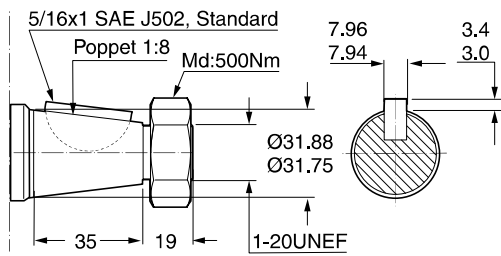

Code 10³⁾

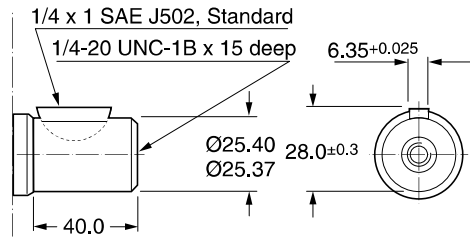

Code 12

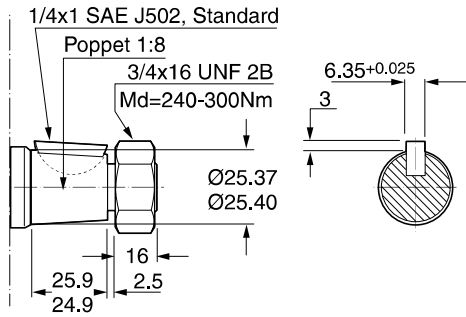

Code 25

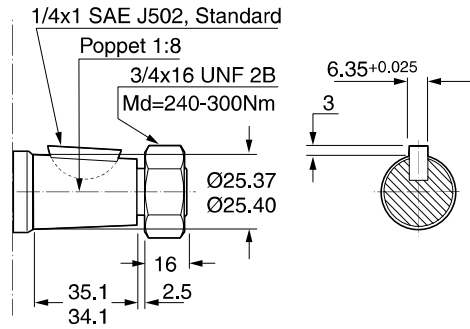

Code 26²⁾

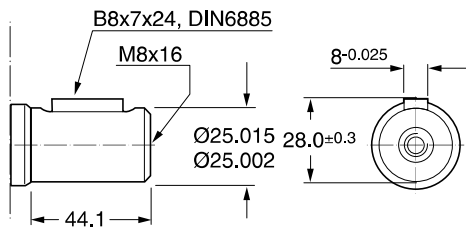

Code 41

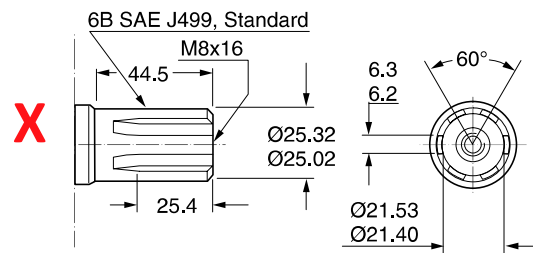

²⁾ **Code 69** = Rostfreie Ausführung
 Stainless steel version
 Version en acier inoxydable
 Versione in acciaio inossidabile
 230 Nm (2100lb in) Max. Drehmoment/
 Max Torque/ Couple maxi/ Coppia max

³⁾ **Code 70** = 25,4 mm - Rostfreie Ausführung
 25,4 mm - Stainless steel version
 25,4 mm - Version en acier inoxydable
 25,4 mm - Versione in acciaio inossidabile
 230 Nm (2100lb in) Max. Drehmoment/
 Max Torque/ Couple maxi/ Coppia max

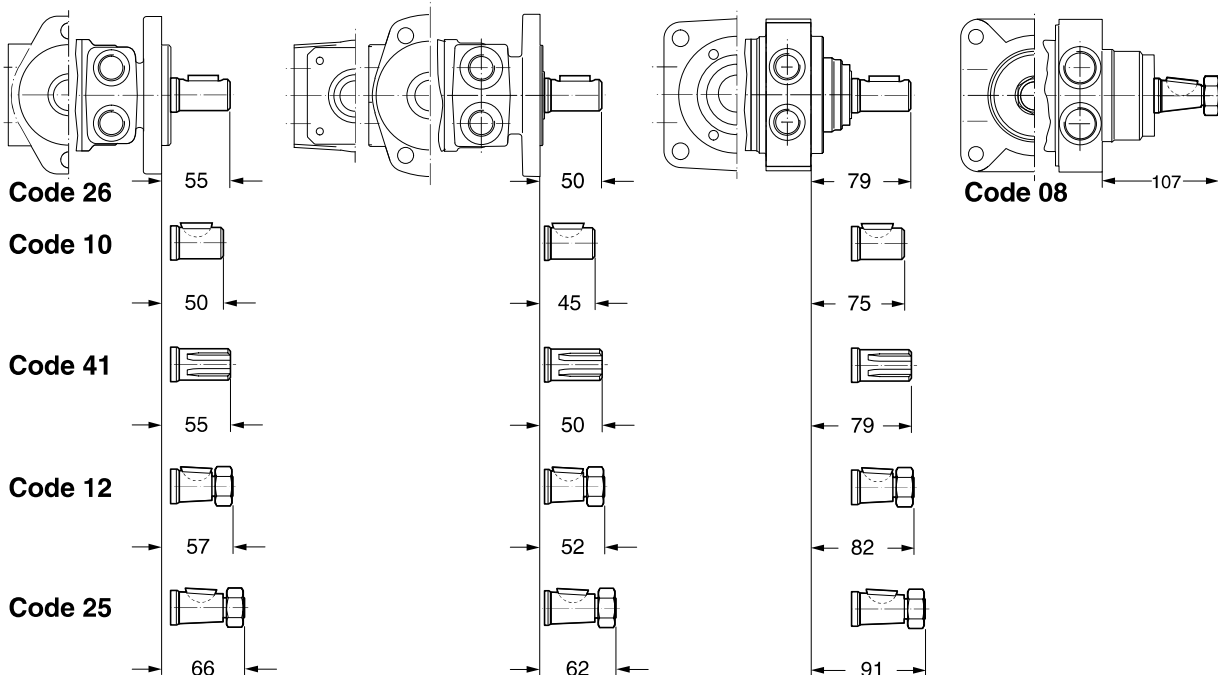

TE/TJ 130

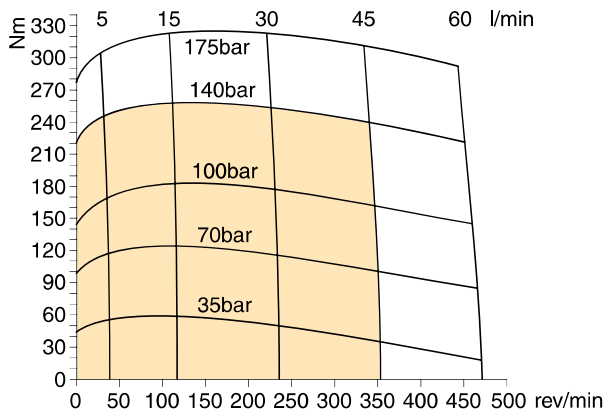

TE/TJ 165

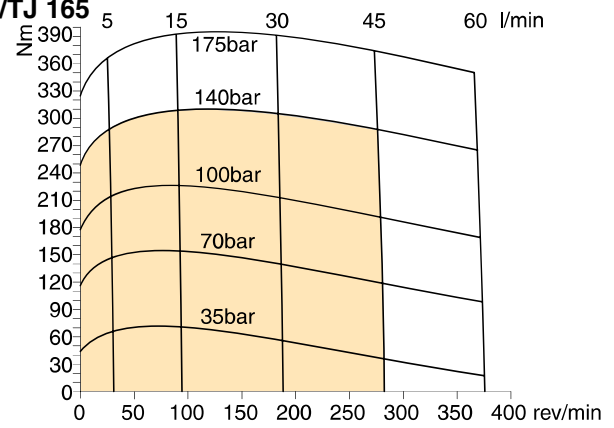

TE/TJ 195

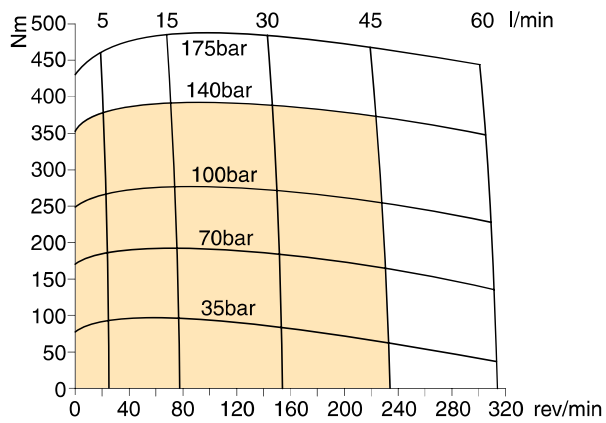

TE/TJ 230

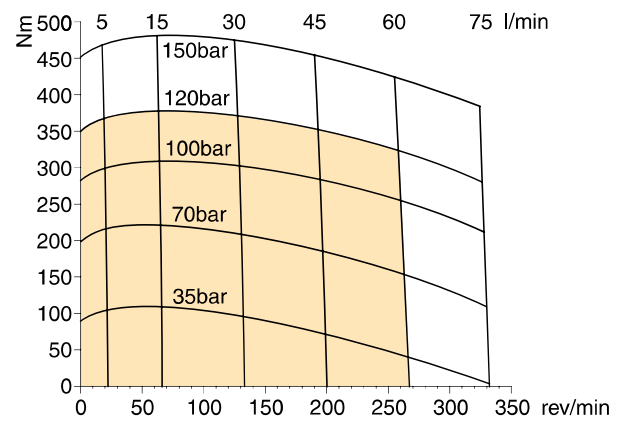

TE/TJ 260

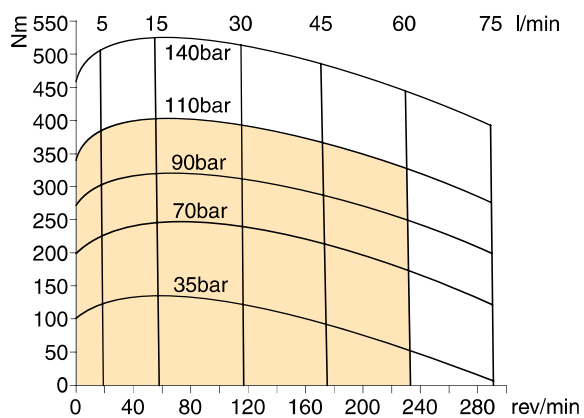

TE/TJ 295

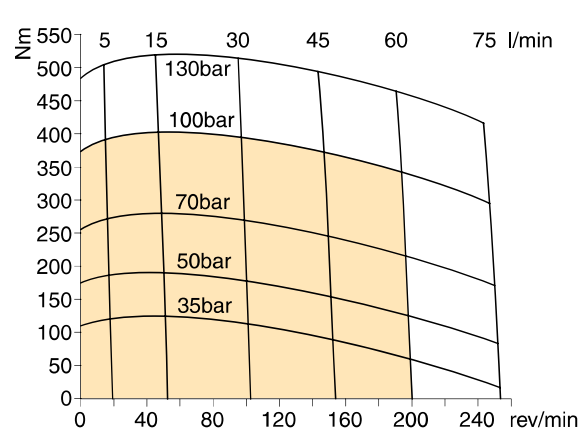

■ Cont. □ Int.

int. =
 Intermittierende Werte maximal 10% von jeder Betriebsminute.
 Fonctionnement interm. 10% max. de chaque minute d'utilisation.
 Intermittent operation rating applies to 10% of every minute.
 Servizio intermittente 10% max di ogni minuto di utilizzazione.

TE Code D

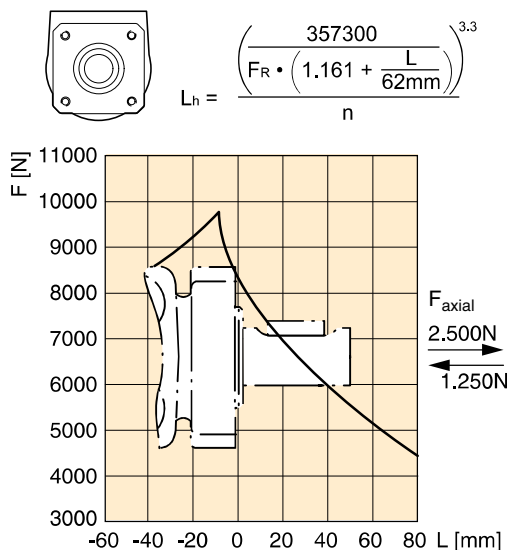

TE Code C

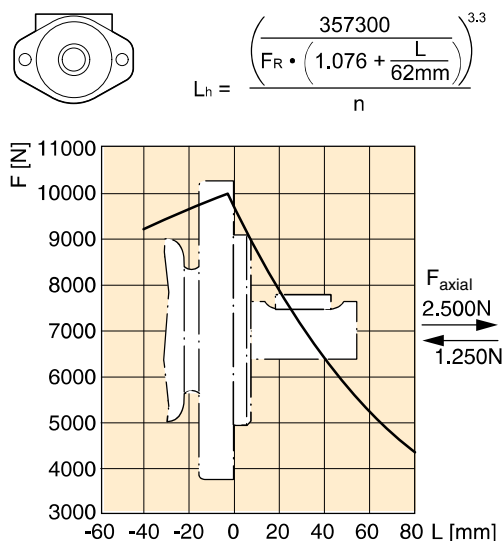

TE Code L

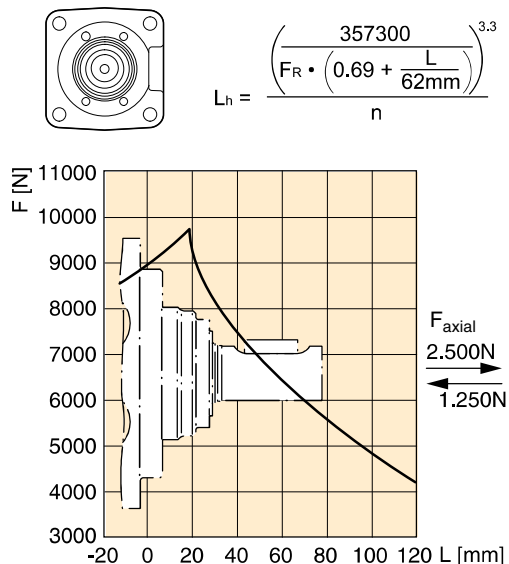

TJ Code U

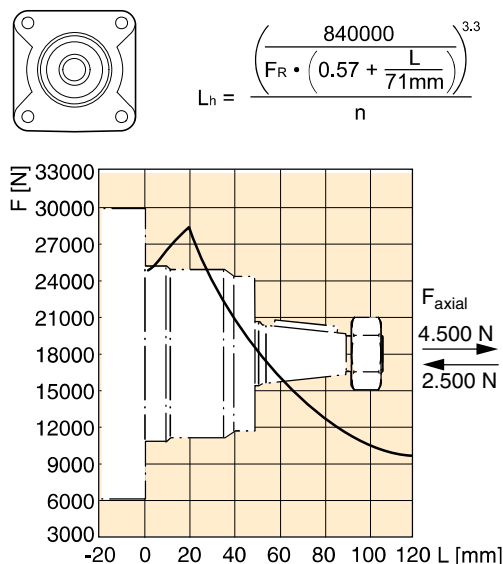

Die Lebensdauer der Radiallager (L_h in Stunden) lässt sich nach folgender Formel berechnen. Die Größe F_R ist durch die mechanische Festigkeit der Abtriebswelle begrenzt (siehe Diagramm). Das Maß "L" ist das Längenmaß vom Gehäuseflansch bis zum Angriffspunkt der Radialkraft F_R .

La durée de vie des roulements radiaux (L_h en heures) peut être calculée par les formules suivantes. La grandeur F_R est limitée par les résistances mécaniques de l'arbre de sortie (voir diagramme). La cote "L" est la longueur entre la bride du carter jusqu'au point d'appui de l'effort radial F_R .

Life time (L_h in hours) of the radial bearings can be calculated with the following formula. The value F_R is limited by the mechanical strength of the shaft (see diagram). The measurement "L" is the length from the housing flange up to the point of impact of the radial force F_R .

La durata dei cuscinetti (L_h in ore) può essere calcolata con la seguente formula. Il valore F_R è limitato dalla resistenza meccanica dell'albero (vedi diagramma). La quota "L" è la distanza tra la flangia del corpo ed il punto di applicazione della forza radiale F_R .

Vorstehende Formeln gelten für eine B10-Lebensdauer.	$L_h = [h]$
The preceding formulas are valid for a B10 duration of life.	$L = [mm]$
Les formules précédentes sont valables pour une durée de vie B10.	$n = [rev/min]$
Le formule precedenti sono valide per una durata della vita B10.	

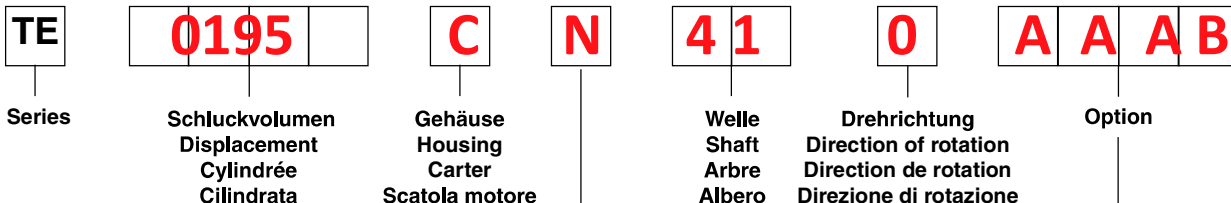

Code	cm ³ /rev
0036	36
0045	41
0050	50
0065	66
0080	82
0100	98
0130	130
0165	163
0195	196
0230	228
0260	261
0295	293
0330	326
0365	370
0390	392

Code	Housing
C	
C	
D	
L	

Code	Port
W	G 1/2
N¹⁾	universal port M8x13
Y	rear port G 1/2 axial

**Anschluss
 Ports
 Plan de raccordement
 Connessioni**

Code	Option
AAAB	standard
AANC	shuttle valve
BBCP ²⁾	internal relief valve 100 bar
BBCN ²⁾	internal relief valve 140 bar
HAAP	external relief valve 100 bar
HAAU	external relief valve 140 bar

²⁾ Nicht verfügbar für Anschluss Y
 Not available for port code Y
 Pas disponible pour raccordement
 code Y
 Non Disponibile per connessioni
 codice Y

Code	Direction
0	 Standard
1	

Code	Shaft
26 69 ³⁾	
26 69 ³⁾	
41	 6B SAE
12	
25	

¹⁾ Nicht verfügbar für Ge-
 häuse L
 Not available for housing
 code L
 Pas disponible pour carter
 code L
 Non Disponibile per Allog-
 giamento codice L

³⁾ 230 Nm (2100lb in) Max. Drehmoment/
 Max Torque/ Couple maxi/ Coppia max

Option Codes

X

Option Code	Description	Series	TE/TJ	TF	TL	TG	TH	TK
AAAA	black paint		x	x	x	x	x	x
AAAB	standard (no paint)		x	x	x	x	x	x
AAAH	FPM seals (no paint)		x	x		x	x	x
AABP	castle nut (no paint)		x	x		x	x	x
AAFX	shuttle valve			x		x	x	
BBBF	internal relief valve 200bar			x		x	x	
BBBJ	internal relief valve 100bar			x		x	x	
BBBM	internal relief valve 70bar			x		x	x	
BBBN	internal relief valve 140bar			x		x	x	
BBCG	internal relief valve 170bar			x		x	x	
HAAF	external relief valve 100bar (M6)			x		x		
HAAP	external relief valve 100bar (M8)		x	x		x	x	
HAAH	external relief valve 140bar (M6)			x		x		
HAAU	external relief valve 140bar (M8)		x	x		x	x	
HAAK	external relief valve 170bar (M6)			x		x		
HAAX	external relief valve 170bar (M8)			x		x	x	
HAAM	external relief valve 200bar (M6)			x		x		
HABA	external relief valve 200bar (M8)			x		x	x	
FSAB	Speedsensor		X	x		x		
FSAA	Speedsensor + black paint		x	x		x		
FSAN	Int Short Speed Sensor, 1500 psi Int Bidirectional Relief, No paint			x		x		