

Performance Information

Series PVP 23/33 Pressure Compensated, Variable Volume, Piston Pumps

Features

- High Strength Cast-Iron Housing for Reliability and Quiet Operation
- Vickers Porting Interchange
- Optional Inlet/Outlet Locations for Ease of Installation
- Replaceable Bronze Port Plate
- Replaceable Piston Slipper Plate
- Thru-Shaft Capability SAE AA, A and B Pilots Offered
- Low Noise Levels
- Fast Response Times
- Metric Pilot Shaft and Ports Available

Controls

- Pressure Compensation
- Remote Pressure Compensation
- Load Sensing
- Torque (Power) Limiting
- Adjustable Maximum Volume Stop
- Low Pressure Standby

Schematic Symbol

(Basic Pump)

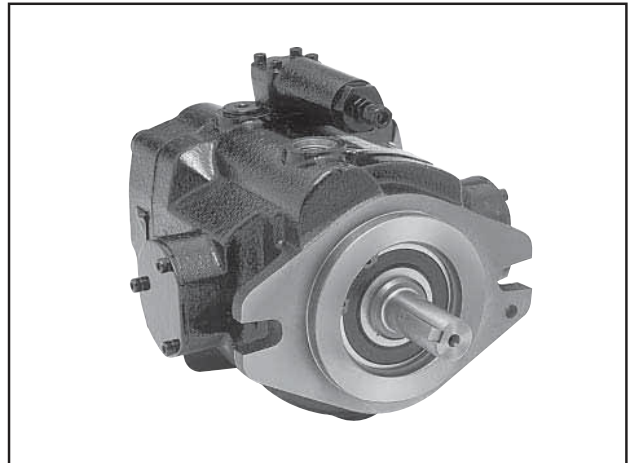
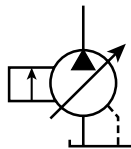

Specifications

Pressure Ratings

Outlet Port: 248 bar (3600 PSI) Continuous (P1)
 310 bar (4500 PSI) Peak (P3)

Inlet Port: 1.72 bar (25 PSI) Maximum
 .17 bar (5 In. Hg.) Vacuum Minimum @ 1800 RPM (See inlet chart for other speeds)

Speed Ratings: 600 to 3000 RPM

Operating Temperature Range: - 40°C to 71°C
 (- 40°F to 160°F)

Housing Material: Cast-Iron

Filtration: Maintain SAE Class 4,
 ISO 16/13,
 ISO 18/15 Maximum

Mounting: SAE "B" or Metric 2-Bolt
 Flange Mount

Installation Data: See page 42 of this catalog for specific recommendations pertaining to system cleanliness, fluids, start-up, inlet conditions, shaft alignment, drain line restrictions and other important factors relative to the proper installation and use of these pumps.

Quick Reference Data Chart

Pump Model	Displacement cc/rev (In ³ /rev)	Pump Delivery @ 21 bar (300 PSI) in LPM (GPM)		† Approx. Noise Levels dB(A) @ Full Flow 1800 RPM (1200 RPM)					Input Power At 1800 RPM, Max. Displacement & 248 bar (3600 PSI)
		1200 RPM	1800 RPM	34 bar	69 bar	138 bar	207 bar	248 bar	
				(500 PSI)	(1000 PSI)	(2000 PSI)	(3000 PSI)	(3600 PSI)	
PVP23	23.0 (1.4)	28.0 (7.4)	42.0 (11.1)	61 (57)	64 (59)	67 (63)	69 (65)	70 (65)	19.7 kw (26.5 hp)
PVP33	33.0 (2.0)	39.4 (10.4)	59.0 (15.6)	64 (59)	66 (59)	68 (62)	70 (64)	71 (65)	27.2 kw (36.5 hp)

† Measured in an anechoic chamber to DIN 45635, measuring error ± 2 dB(A).
 Fluid used: petroleum oil to ISO VG 46; temperature = 50°C (122°F).

Since many variables such as mounting, tank style, plant layout, etc., effect noise levels, it cannot be assumed that the above readings will be equal to those in the field. The above values are for guidance in selecting the proper pump.

hpm102-1.p65, lw, jk

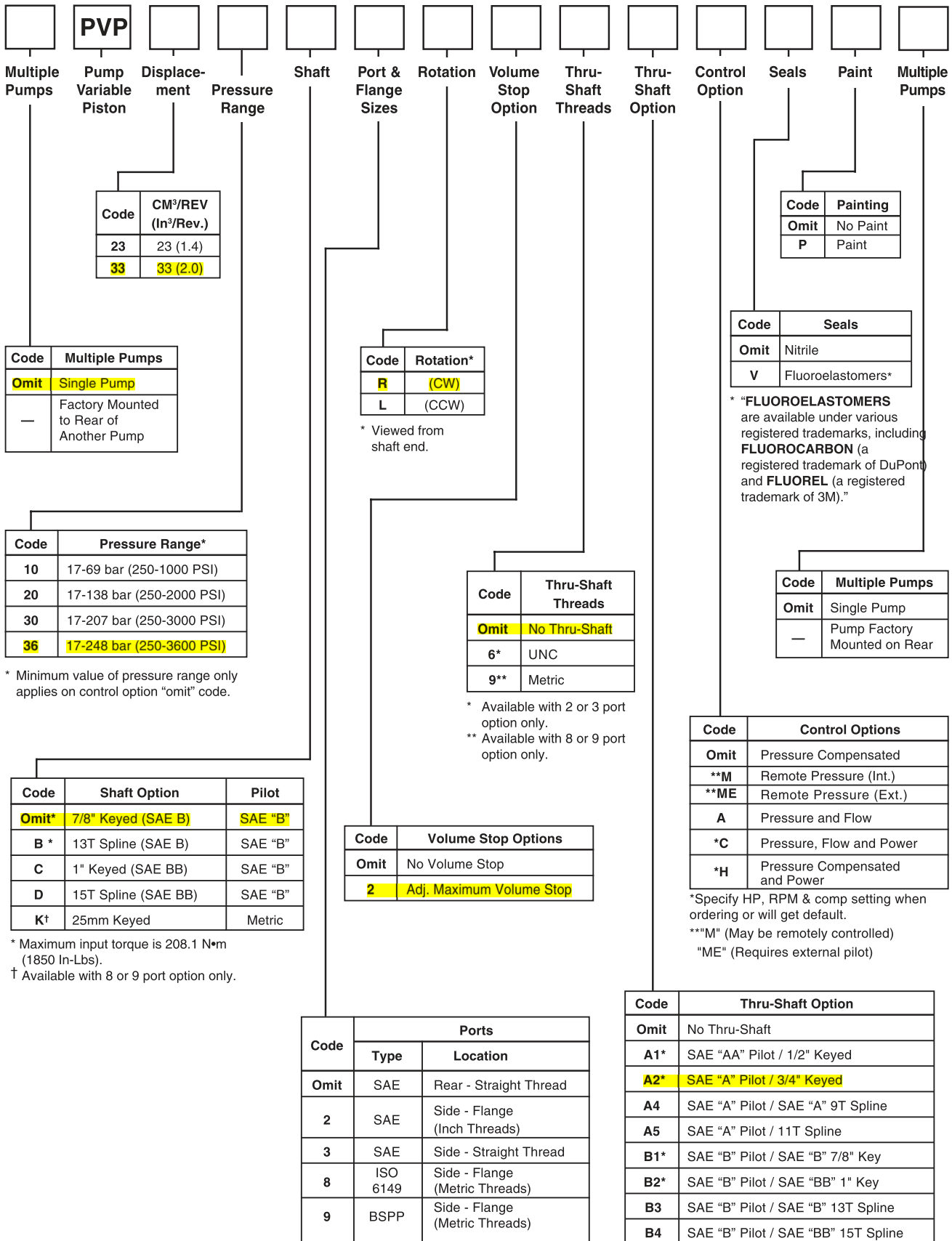

* Minimum value of pressure range only applies on control option "omit" code.

* Maximum input torque is 208.1 N*m (1850 In-Lbs).

† Available with 8 or 9 port option only.

* Viewed from shaft end.

* Available with 2 or 3 port option only.

** Available with 8 or 9 port option only.

*Specify HP, RPM & comp setting when ordering or will get default.

**"M" (May be remotely controlled)

"ME" (Requires external pilot)

* Keyed option only available with UNC threads.

Typical Performance Data - Fluid: Standard Hydraulic Oil 100 SSU @ 49°C (120°F)

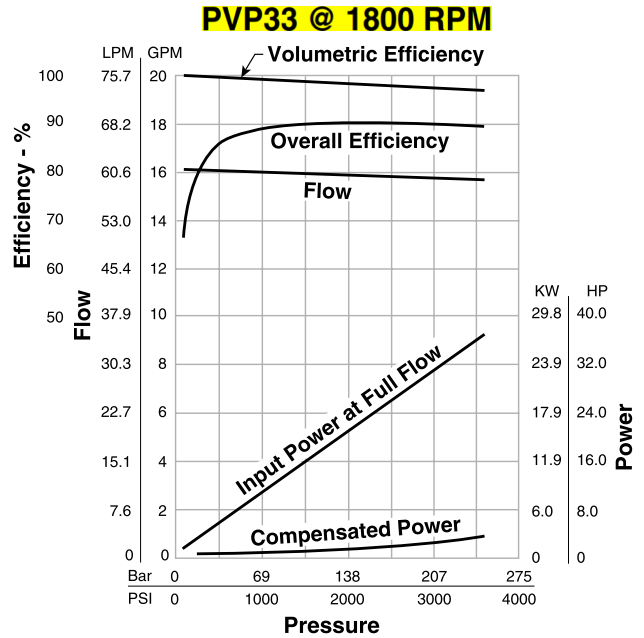
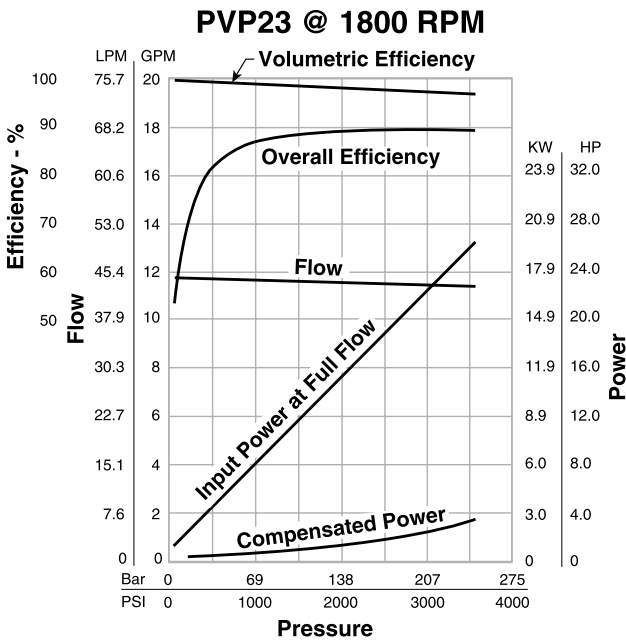

NOTE: The efficiencies and data in the graph are good only for pumps running at 1800 RPM and stroked to maximum. To calculate approximate horsepower for the other conditions, use the following formula:

$$HP = \left[\frac{Q \times (PSI)}{1714} \right] + (CHp)$$

Actual GPM is directly proportional to drive speed and maximum volume setting. Flow loss, however, is a function of pressure only.

WHERE:

Q = Actual Output Flow in GPM

PSI = Pressure At Pump Outlet

CHp = Input Horsepower @ Full Compensation @ 1800 RPM (from graph read at operating pressure)

**PVP 23/33
 Inlet Characteristics at Full Displacement**
 (Graph only valid at sea level)

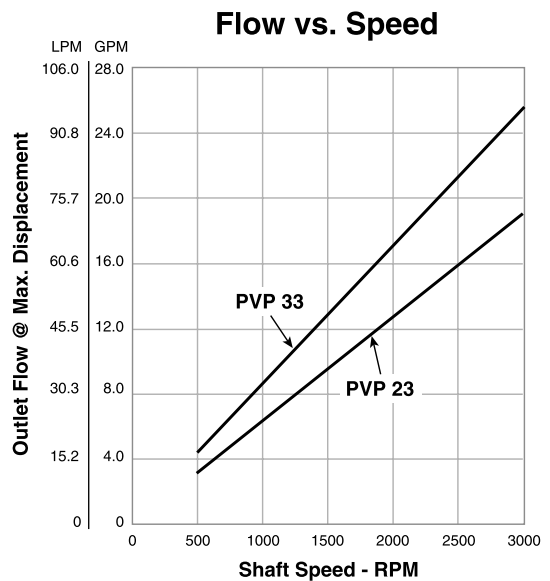
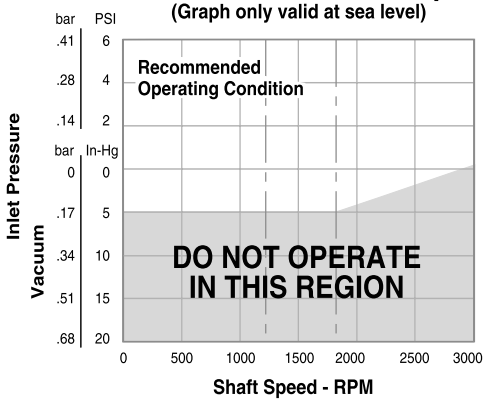

Typical Performance Data - Fluid: Standard Hydraulic Oil 100 SSU @ 49°C (120°F)

Power Control

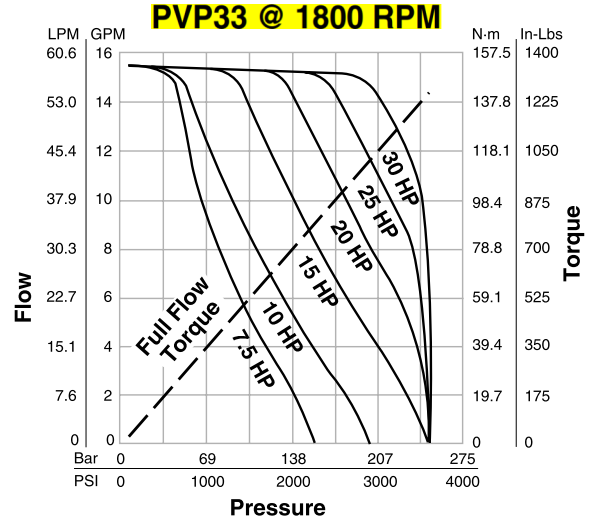
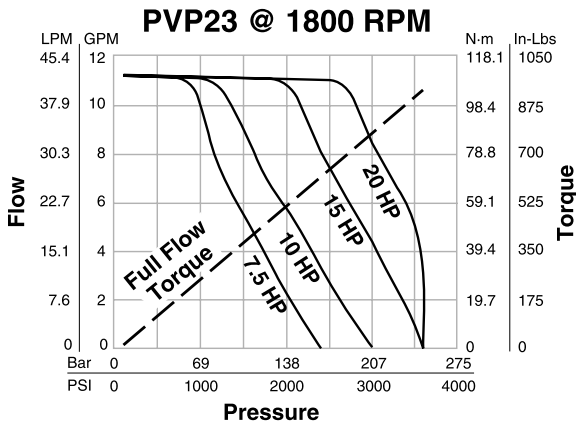

Response Times

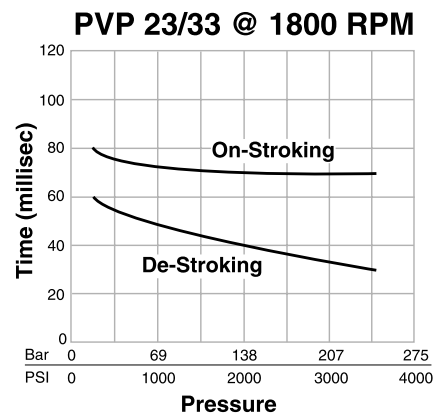
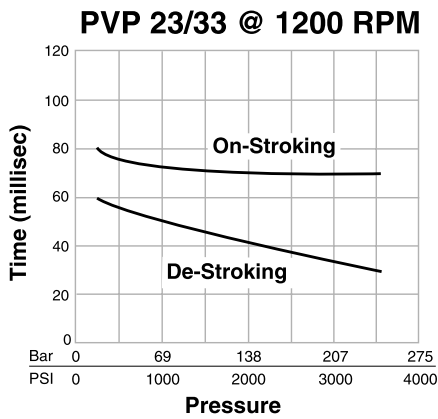

**PVP 23/33
 Approximate Case Drain Flow
 @ 1800 RPM**

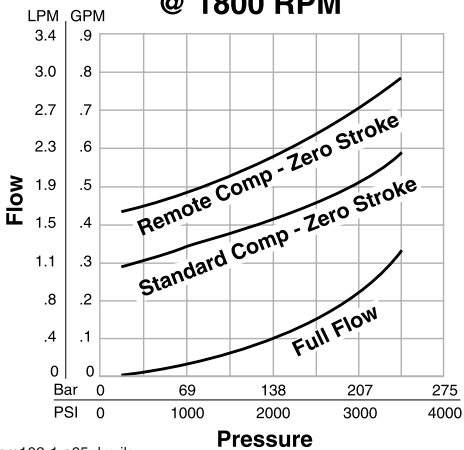

**PVP 23/33
 Compensated Power
 @ 1800 RPM**

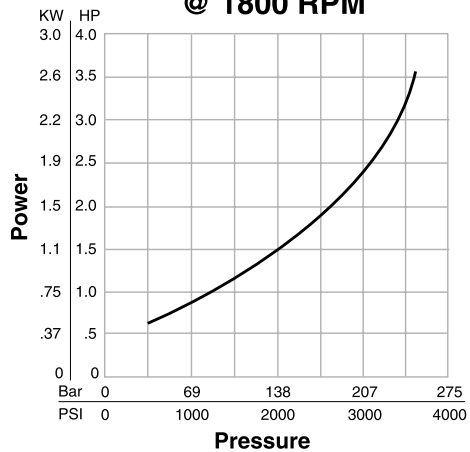

hpm102-1.p65, lw, jk



Rear Ported Pump Dimensions

* Inch equivalents for millimeter dimensions are shown in (**).

NOTES:

1. Righthand (CW) rotation pump shown. Lefthand (CCW) pumps have inlet and outlet ports reversed.
2. Pump shown with standard pressure compensator (control option "omit").

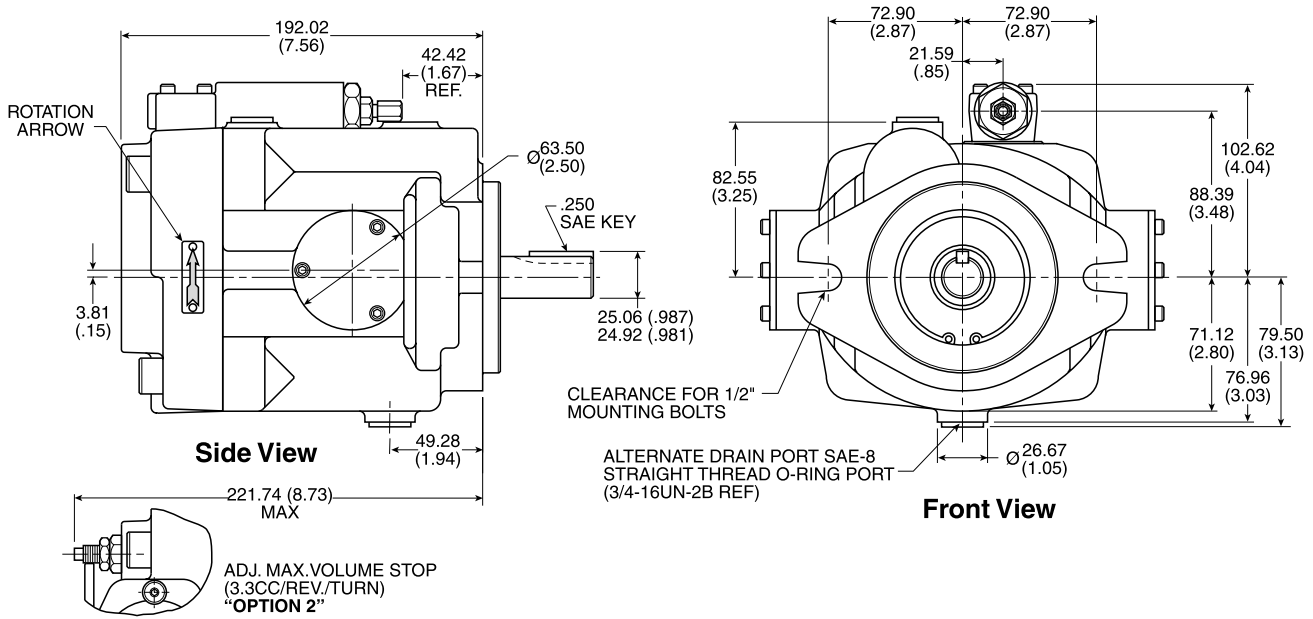
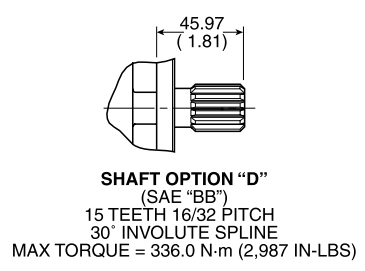
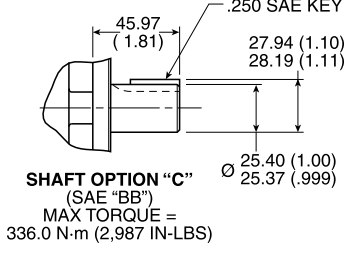
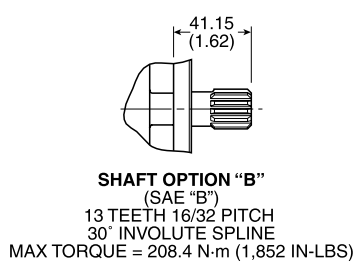
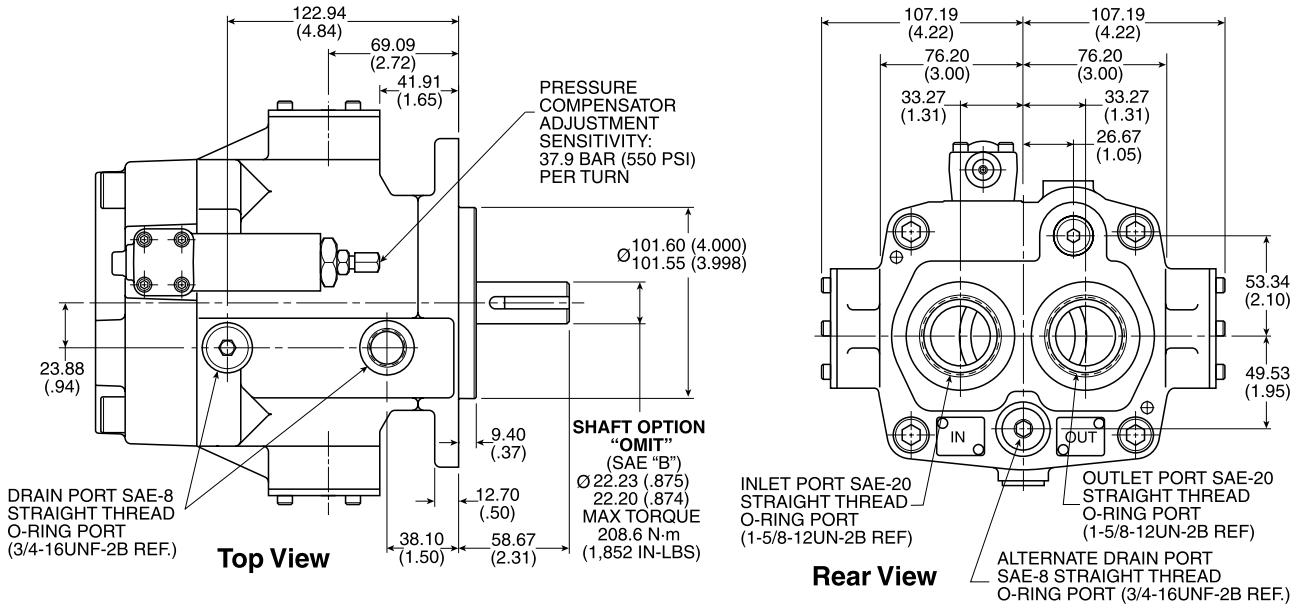

hpm102-1.p65, lw, jk



Side Ported – Options 2 & 3 Dimensions

* Inch equivalents for millimeter dimensions are shown in (**).

NOTES:

1. Righthand (CW) rotation pump shown. Lefthand (CCW) pumps have inlet and outlet ports reversed.
2. Pump shown with standard pressure compensator (control option "omit").

Port Location		
Option	A	Inlet and Outlet Port
2	148.84 (3.10)	1-1/4" SAE 4-Bolt Flange 7/16-14 Threads Standard Pressure Series (Code 61)
3	152.40 (3.22)	SAE-20 Straight Thread (1-5/8-12UN-2B)

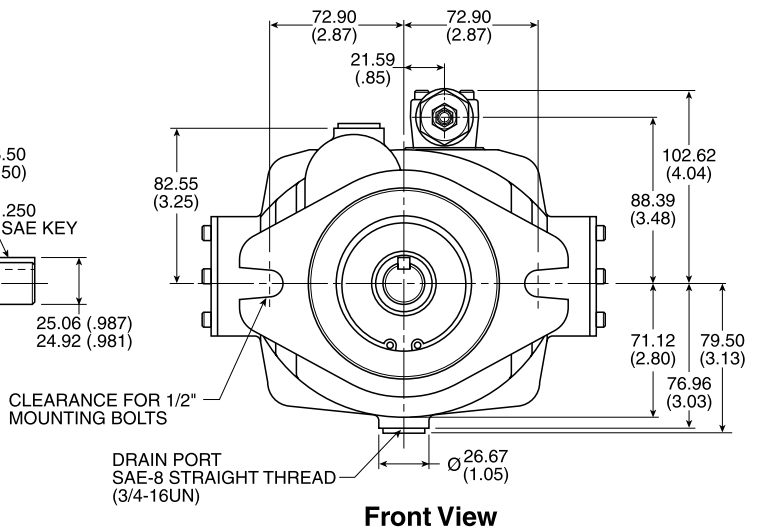
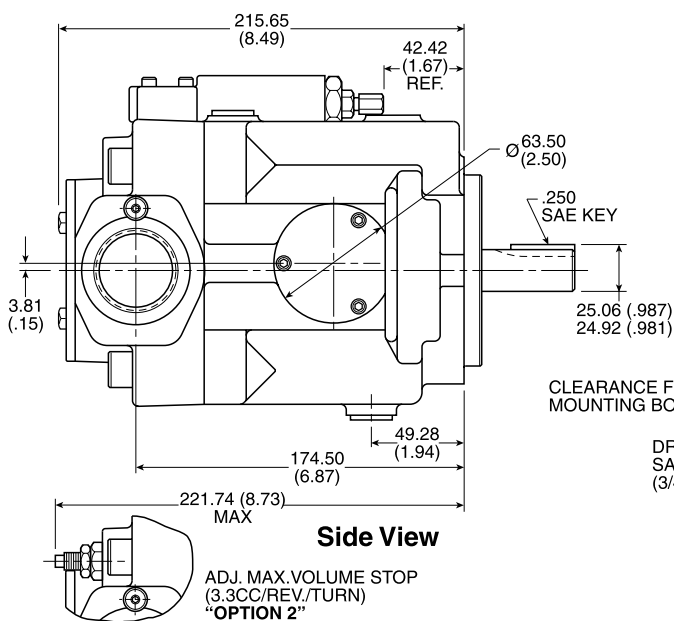
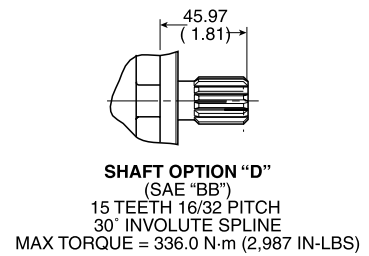
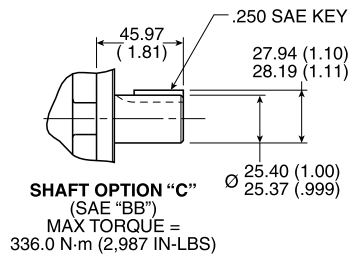
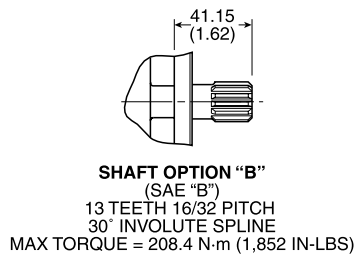
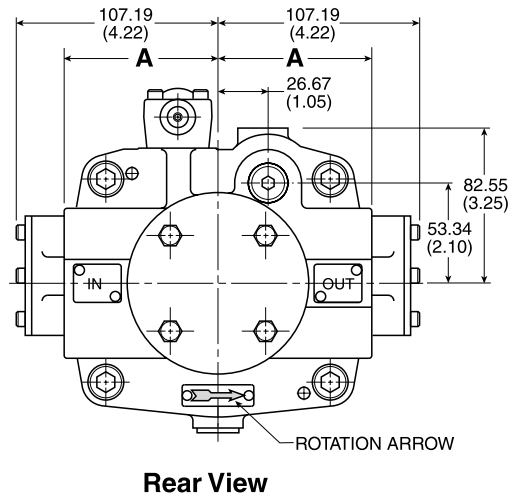
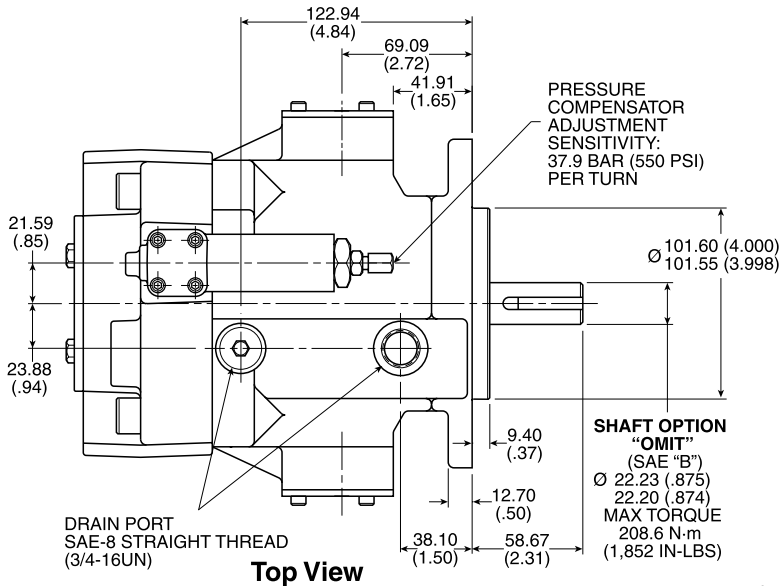

Side Ported – Options 8 & 9 Dimensions

* Inch equivalents for millimeter dimensions are shown in (**).

NOTES:

1. Righthand (CW) rotation pump shown. Lefthand (CCW) rotation pump will have inlet and outlet ports reversed.
2. Pump shown with standard pressure compensator (control option "omit").

Shaft Option	Pilot Dimensions			
	A	B	C	D
Omit B, C, D	101.60/101.55 (4.000/3.998)	9.40 (.37)	72.90 (2.87)	ø 12.70 (.50)
K	100.00/99.95 (3.937/3.935)	9.14 (.36)	69.85 (2.75)	ø 12mm

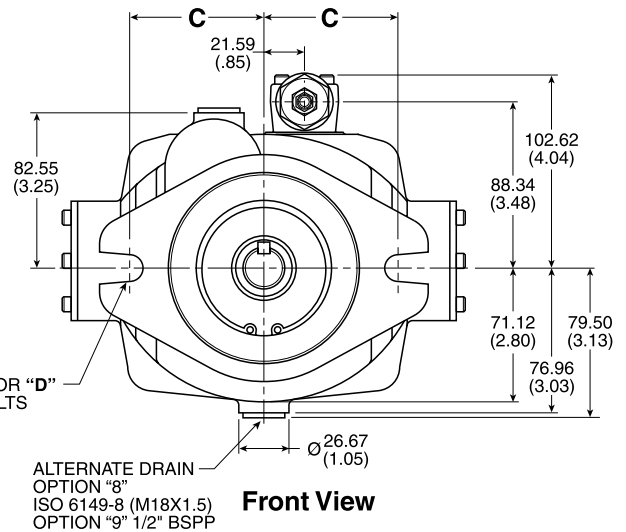
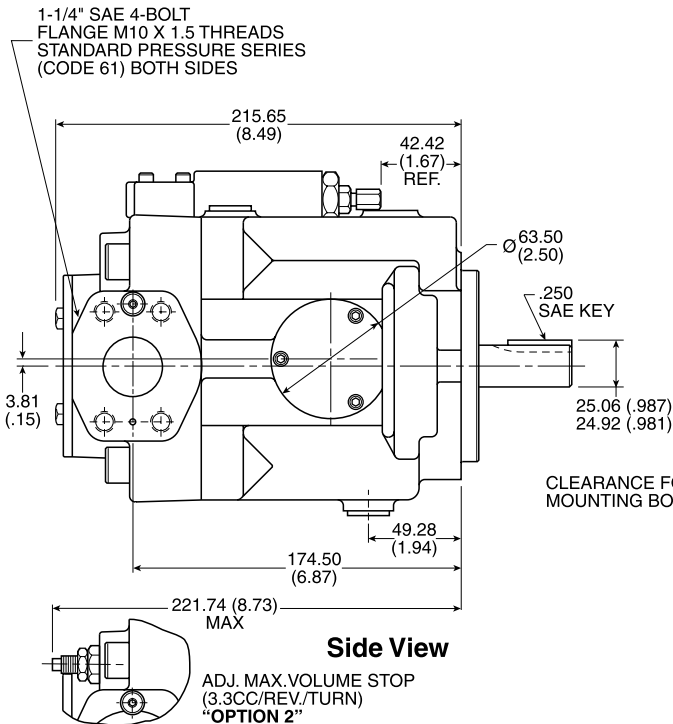
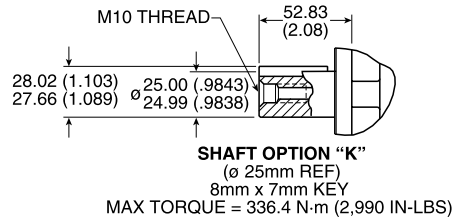
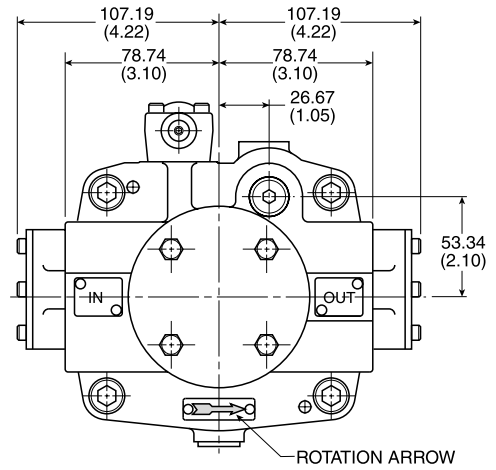
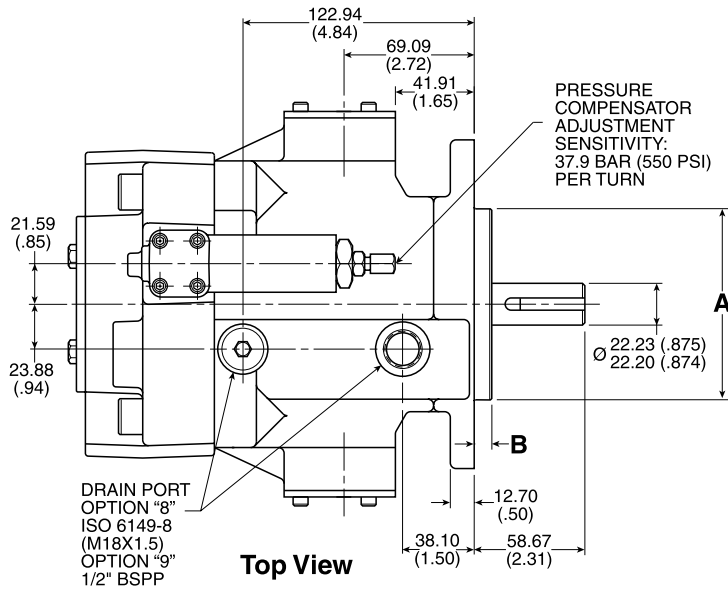

Thru-Shaft Pump Dimensions

* Inch equivalents for millimeter dimensions are shown in (**).

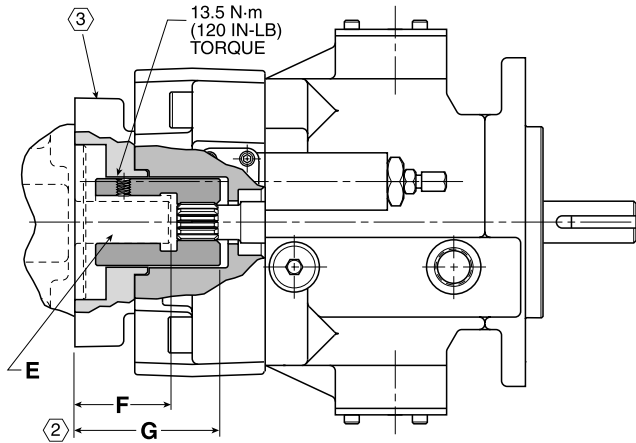

Top View

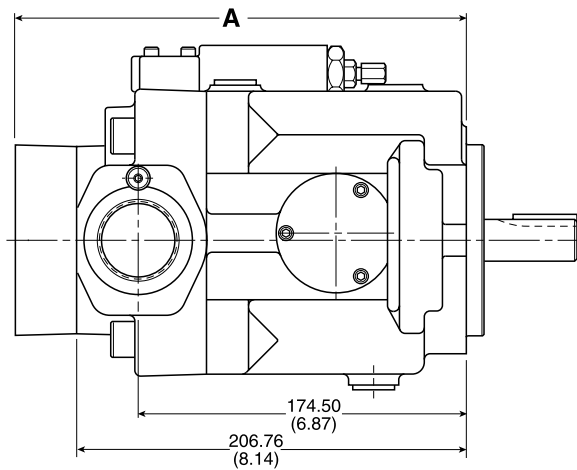

Side View

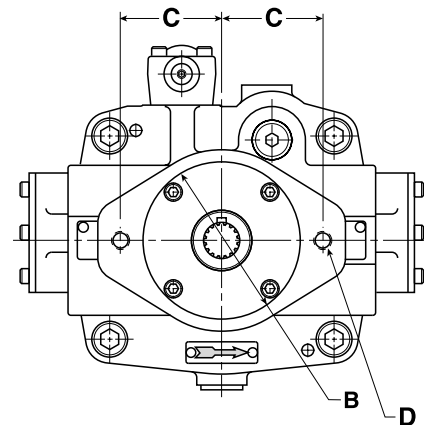

Rear View

NOTES:

1. Righthand (CW) rotation side ported pump shown. Lefthand (CCW) pump will have inlet and outlet ports reversed.
- ②. Install coupler on shaft of rear pump to dimension shown then lock down coupler using set screws.
- ③. Options, 6A2, 6A4, 9A4 and 9A5 Design Series 20 have a gasket seal, all other thru-shaft options incorporate an o-ring seal and have an o-ring groove.
4. Maximum torque transmitting capacity 209 N•m (1850 in-lbs).

Thru-Shaft Options							
Variation	A	B	C	D	E	F	G
6A1	232.16 (9.14)	50.83/50.85 (2.001/2.002)	41.28 (1.63)	5/16-18UNC-2B	12.70 x 3.18 (.50 x .125) Key	38.10 (1.50)	69.09 (2.72)
6A2	238.51 (9.39)	82.58/82.60 (3.251/3.252)	53.19 (2.09)	3/8-16UNC-2B	19.05 x 4.76 (.75 x .188) Key	44.45 (1.75)	75.44 (2.97)
6A4	238.51 (9.39)	82.58/82.60 (3.251/3.252)	53.19 (2.09)	3/8-16UNC-2B	9 Tooth 16/32 Pitch	31.75 (1.25)	N/A
6A5	238.51 (9.39)	82.58/82.60 (3.251/3.252)	53.19 (2.09)	3/8-16UNC-2B	11 Tooth 16/32 Pitch	31.75 (1.25)	N/A
6B1	252.48 (9.94)	101.63/101.65 (4.001/4.002)	73.03 (2.88)	1/2-13UNC-2B	22.23 x 6.35 (.875 x .25) Key	58.67 (2.31)	89.41 (3.52)
6B2	252.48 (9.94)	101.63/101.65 (4.001/4.002)	73.03 (2.88)	1/2-13UNC-2B	25.40 x 6.35 (1.00 x .25) Key	45.97 (1.81)	89.41 (3.52)
6B3	252.48 (9.94)	101.63/101.65 (4.001/4.002)	73.03 (2.88)	1/2-13UNC-2B	13 Tooth 16/32 Pitch	41.15 (1.62)	N/A
6B4	252.48 (9.94)	101.63/101.65 (4.001/4.002)	73.03 (2.88)	1/2-13UNC-2B	15 Tooth 16/32 Pitch	45.97 (1.81)	N/A
9A4	238.51 (9.39)	82.58/82.60 (3.251/3.252)	53.19 (2.09)	M10 x 1.50	9 Tooth 16/32 Pitch	31.75 (1.25)	N/A
9A5	238.51 (9.39)	82.58/82.60 (3.251/3.252)	53.19 (2.09)	M10 x 1.50	11 Tooth 16/32 Pitch	31.75 (1.25)	N/A
9B3	252.48 (9.94)	101.63/101.65 (4.001/4.00)	73.03 (2.88)	M12 x 1.75	13 Tooth 16/32 Pitch	41.15 (1.62)	N/A
9B4	252.48 (9.94)	101.63/101.65 (4.001/4.00)	73.03 (2.88)	M12 x 1.75	15 Tooth 16/32 Pitch	45.97 (1.81)	N/A

Remote Compensator Control Pump Dimensions

* Inch equivalents for millimeter dimensions are shown in (**).

NOTES:

1. Righthand (CW) rotation rear ported pump shown. Lefthand (CCW) pumps will have inlet and outlet ports reversed.
2. When controlling pump compensator pressure with remote relief valve, size relief valve to pass a minimum of 1.89 LPM (.5 GPM).
3. Remote compensator shown on rear ported pump. Also available on side ported or thru-shaft option pumps.

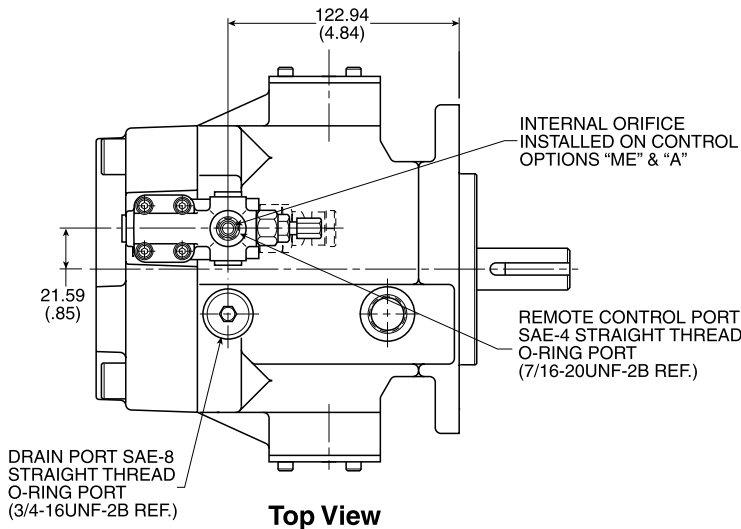

Top View

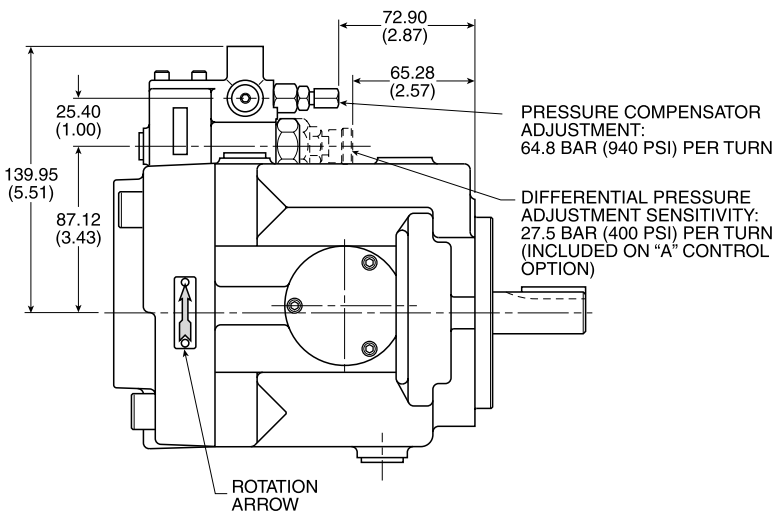
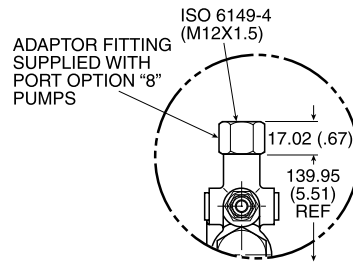
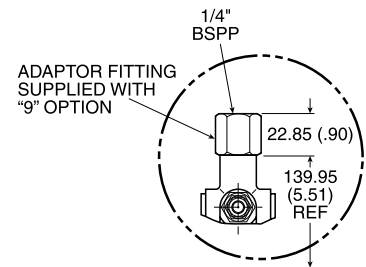

Side View

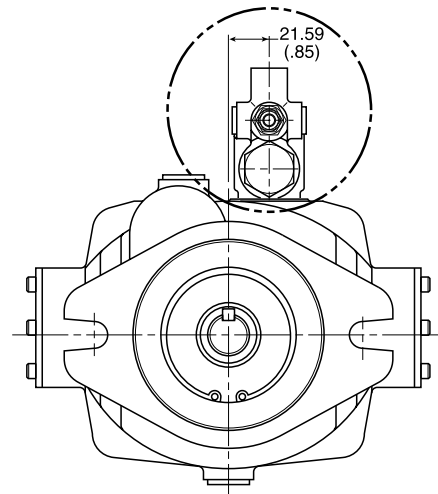

Front View

Power (Torque) Control Pump Dimensions

* Inch equivalents for millimeter dimensions are shown in (**).

NOTES:

1. Righthand (CW) rotation rear ported pump shown. Lefthand (CCW) pumps will have inlet and outlet ports reversed.
2. Power control shown on rear ported pump. Also available on side ported or thru-shaft option pumps.

