

**Dimensions** Millimeters (Inches)

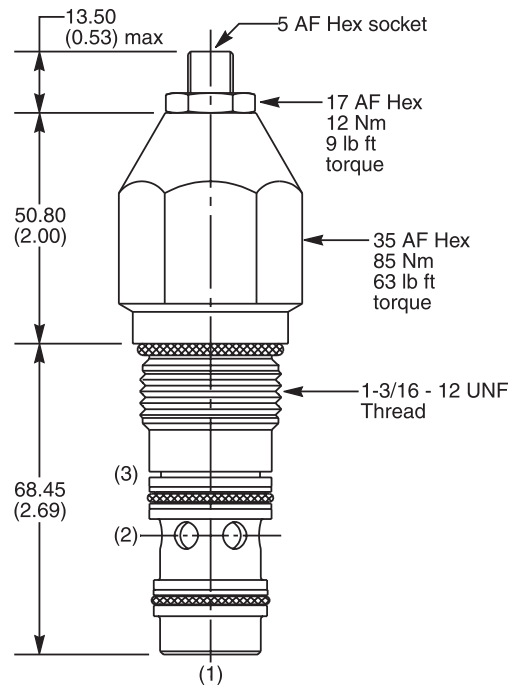

**Ordering Information**

<b>E6</b>	<b>B</b>	<b>060</b>	<b>Z</b>	<b>N</b>	<b>409</b>
Load Control Valve	Pilot Ratio		Adjustment Style	Seals	Suffix Number

**Highlighted** represents preferred options that offer the shortest lead times. Other options may be available, but at extended lead times.

Code	Pilot Ratio
B	3:1

Code	Adjustment Style
Z	Screw Adjust (Standard)

Code	Seals / Kit No.
N	Nitrile, Buna-N (Std.) / (SK30008N-1)

Code	Suffix Number
409	High flow design with extra dampening

*Standard valve is set to crack at 215 Bar (3120 PSI). Valve to be set to 1.3 times maximum load induced pressure.*  
*Other settings are available, please contact Parker Sales.*

Order Bodies Separately  
 See section BC

<b>LB10</b>	<input type="checkbox"/>	<input type="checkbox"/>
Line Body	Porting	Body Material

Code	Porting
069	1" SAE (main) 1/4" SAE (aux)
234	3/4" SAE Dual Cavity

Code	Body Material
S	Steel
A	Aluminium

CV
Check Valves
SH
Shuttle Valves
LM
Load/Motor Controls
FC
Flow Controls
PC
Pressure Controls
LE
Logic Elements
DC
Directional Controls
MV
Manual Valves
SV
Solenoid Valves
PV
Proportional Valves
CE
Coils & Electronics
CB
Carpak Bodies
BC
Bodies & Cavities
TD
Technical Data