

© THIS DRAWING IS THE PROPERTY OF BOSCH REXROTH AG. MITHER REPRODUCTION OR NOT BE REPRODUCED OR TRANSMITTED IN ANY FORM OR BY ANY MEANS, ELECTRONIC OR MECHANICAL, INCLUDING PHOTOCOPYING, RECORDING, OR BY ANY INFORMATION STORAGE AND RETRIEVAL SYSTEM.

© Alle Rechte bei Bosch Rexroth AG, auch für den Fall von Schutzrechtsverletzungen. Jede Vervielfältigung, wie Kopieren- und Weitergeben, ist ohne schriftliche Genehmigung von Bosch Rexroth AG.

Weil: Fremdspr. Angebotszeichnungen FURTHER FOREIGN LANGUAGE OFFER DINGS

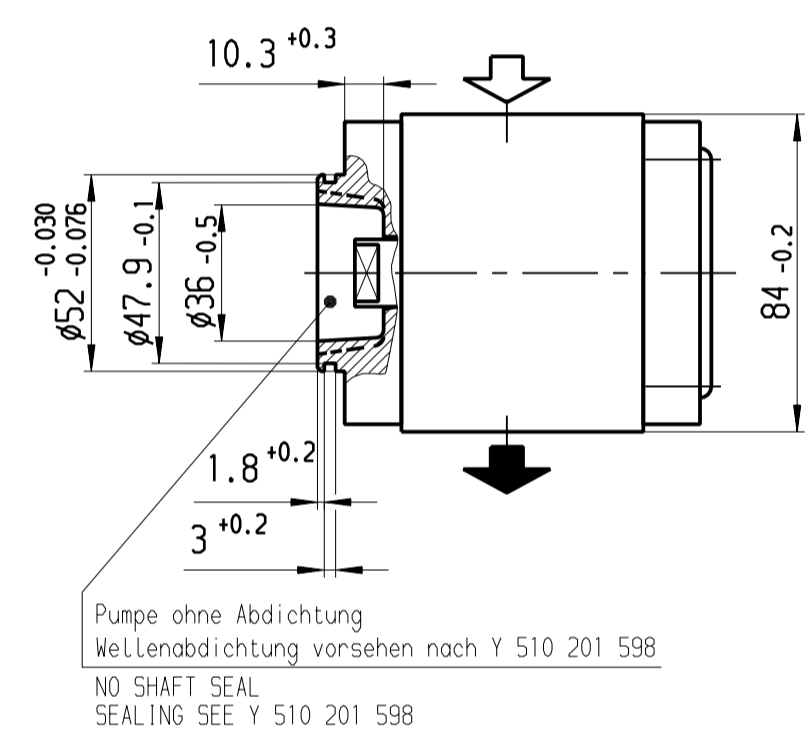
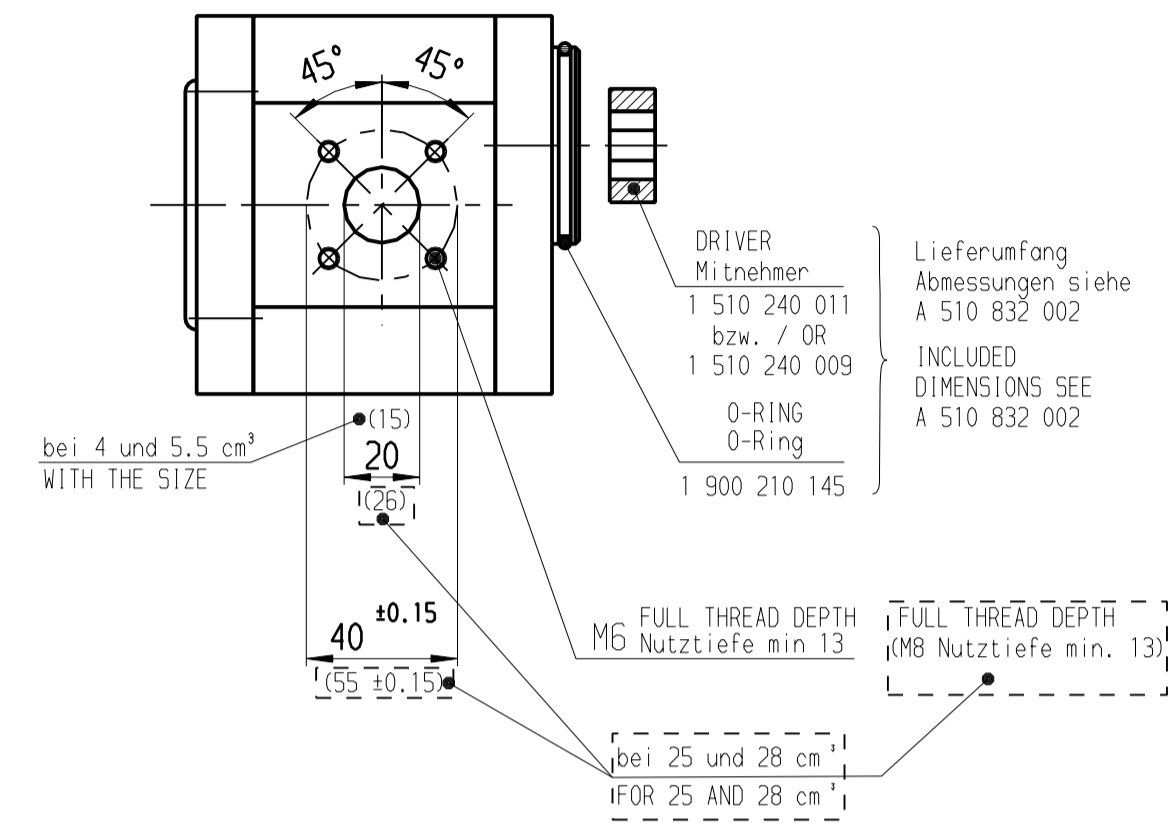
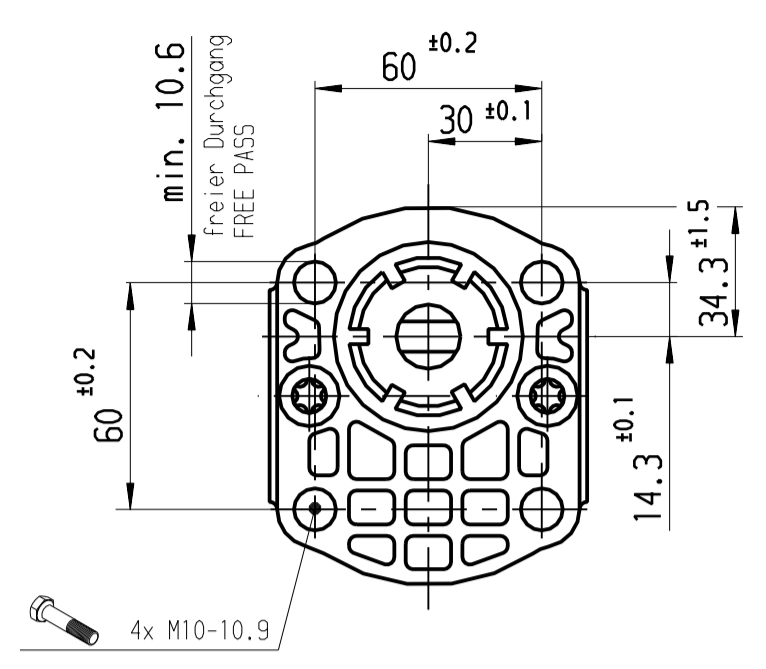
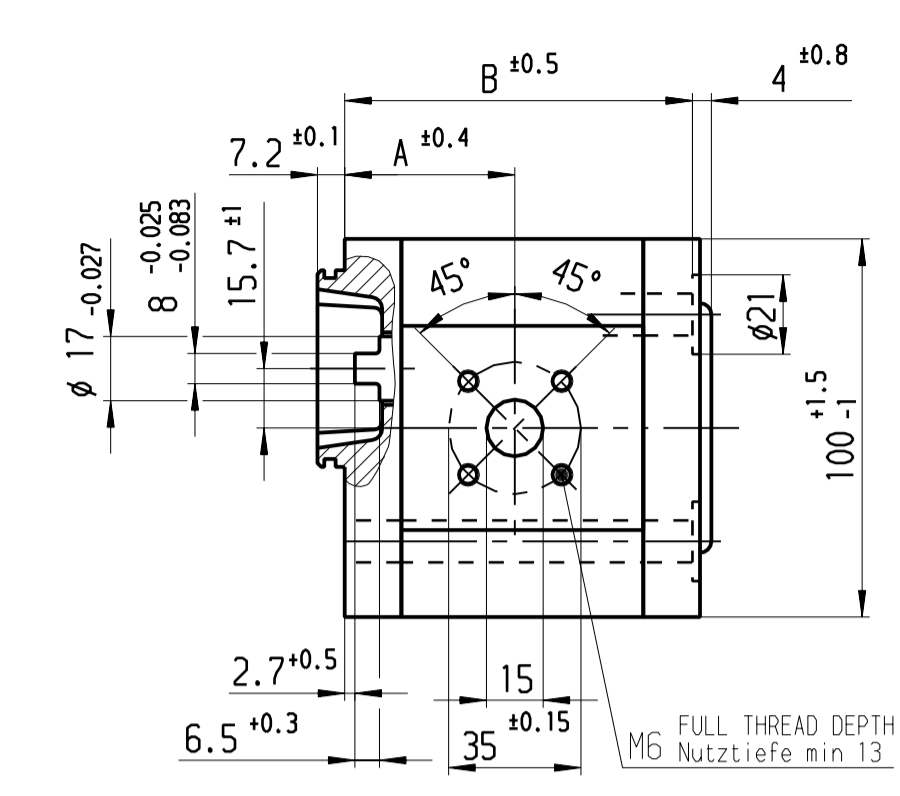

HINWEISE UND ANGABEN

Betriebsbedingungen siehe Y 510 201 598

Die Darstellung zeigt eine rechtsdrehende Pumpe (Auf Antriebswelle gesehen). Bei linksdrehender Pumpe ist Druck- und Sauganschluß vertauscht. Die Pumpe darf nur in angegebener Drehrichtung drehen.

Alle Ölanschlüsse für Transport und Lagerung staubdicht verschlossen, z.B. mit Kunststoffstopfen

ADDITIONAL INFORMATION

WORKING CONDITIONS SEE Y 510 201 598

CCW ROTATION SHOWN. CCW ROTATION PUMPS HAVE PRESSURE AND SUCTION PORT ON OPPOSITE SIDE. PUMP MUST BE DRIVEN IN PROPER DIRECTION ONLY.

ALL OIL PORTS CLOSED PROPERLY AGAINST DUST FOR TRANSPORT AND STORAGE, E.G. WITH PLASTIC CLOSURE CAPS.

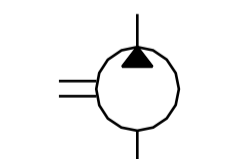

B 510-E32-023	0 510 715 323	...-22-028 LNT 20 MB-50033	Links/CCW	28	3000	130	63.1	125.3	Mitnehmer / Driver	1 510 240 011
B 510-E32-024	0 510 715 018	...-22-028 RNT 20 MB-50033	rechts/CW	28	3000	130	63.1	125.3	Mitnehmer / Driver	1 510 240 011
B 510-E32-021	0 510 715 322	...-22-025 LNT 20 MB-50033	Links/CCW	25	3000	150	60.7	120.5	Mitnehmer / Driver	1 510 240 011
B 510-E32-022	0 510 715 017	...-22-025 RNT 20 MB-50033	rechts/CW	25	3000	150	60.7	120.5	Mitnehmer / Driver	1 510 240 011
B 510-232-016	0 510 715 307	...-12-022 LNT 20 MB	Links/CCW	22.5	2500	160	52.6	104.1	Mitnehmer / Driver	1 510 240 011
B 510-232-015	0 510 715 004	...-12-022 RNT 20 MB	rechts/CW	22.5	2500	160	52.6	104.1	Mitnehmer / Driver	1 510 240 011
B 510-232-034	0 510 615 321	...-12-019 LNT 20 MB	Links/CCW	19	3000	190	45.0	98.7	Mitnehmer / Driver	1 510 240 011
B 510-232-033	0 510 615 008	...-12-019 RNT 20 MB	rechts/CW	19	3000	190	45.0	98.7	Mitnehmer / Driver	1 510 240 011
B 510-232-032	0 510 615 315	...-12-016 LNT 20 MB	Links/CCW	16	3000	230	45.0	93.7	Mitnehmer / Driver	1 510 240 011
B 510-232-031	0 510 615 007	...-12-016 RNT 20 MB	rechts/CW	16	3000	230	45.0	93.7	Mitnehmer / Driver	1 510 240 011
B 510-232-030	0 510 515 340	...-12-014 LNT 20 MB	Links/CCW	14	3000	280	45.0	90.3	Mitnehmer / Driver	1 510 240 011
B 510-232-029	0 510 515 019	...-12-014 RNT 20 MB	rechts/CW	14	3000	280	45.0	90.3	Mitnehmer / Driver	1 510 240 011
B 510-232-028	0 510 515 311	...-12-011 LNT 20 MB	Links/CCW	11	3500	280	44.5	85.3	Mitnehmer / Driver	1 510 240 009
B 510-232-027	0 510 515 005	...-12-011 RNT 20 MB	rechts/CW	11	3500	280	44.5	85.3	Mitnehmer / Driver	1 510 240 009
B 510-232-005-12-010 LNT 20 MB	Links/CCW	10	3500	280	44.5	83.6	Mitnehmer / Driver	1 510 240 009
B 510-232-026	0 510 415 314	...-12-008 LNT 20 MB	Links/CCW	8	4000	280	40.7	80.3	Mitnehmer / Driver	1 510 240 009
B 510-232-025	0 510 415 006	...-12-008 RNT 20 MB	rechts/CW	8	4000	280	40.7	80.3	Mitnehmer / Driver	1 510 240 009
B 510-232-024	0 510 315 305	...-12-005 LNT 20 MB	Links/CCW	5.5	4000	280	38.6	76.2	Mitnehmer / Driver	1 510 240 009
B 510-232-023	0 510 315 005	...-12-005 RNT 20 MB	rechts/CW	5.5	4000	280	38.6	76.2	Mitnehmer / Driver	1 510 240 009
B 510-232-022	0 510 215 307	...-12-004 LNT 20 MB	Links/CCW	4	4000	280	37.4	73.7	Mitnehmer / Driver	1 510 240 009
B 510-232-021	0 510 215 007	...-12-004 RNT 20 MB	rechts/CW	4	4000	280	37.4	73.7	Mitnehmer / Driver	1 510 240 009

DRAWING	PART NUMBER	DESIGNATION	DIR. OF ROTATION	DISPLACEMENT	MAX. SPEED	MAX. PRESSURE	DIMENSIONS		REMARKS
				[cm ³ /U]	[U/min]	[bar]	A	B	
							Maß	Maß	
							[mm]	[mm]	

Dokumententyp / DOCUMENT TYPE		AGZ	Nicht toL. Maße NON-TOLERANCED DIM. ± 0.3 mm, ± 1°		ISO E	Maßstab SCALE 1:2	Gewicht WEIGHT OFFER DRAWING
14 51 DRENE 0846		Bs	02.05.2005	Bd	Gr.St.	Benennung/ TITLE	
13 510/04/74V		Fr	15.09.2004	.	VOLUME	Hydrozahnradpumpe	
12 51 AZENG 0352		Wr	24.02.2004	.	gez/DWN	Baureihe "AZPF"	
11 51 AZENG 0264		Wr	13.01.2004	.	gez/CHK	Original: DC-MA/EPE	
17 51 DRENE 2386		Bs	13.10.2009	Ko	gez/APP	Nr./ NO. A 510 232 021	
16 51 DRENE 2378		We	15.07.2009	.	DIN A2	de/en	
15 51 DRENE 0954		Ko	19.07.2005	.	Original: DC-MA/EPE	Blatt SHEET 1	
Nr. Änderung CHANGE		gez. DWN.	gültig VALID	gepr. CHK.	MED	3 BL/SH	
Ers.f./ REPLACES		A 510 232 021		02.02.1979/Ers.d./ REPLAC.BY		Ausfuellanleitung N12A D11/1 beachten!	

OBSERVE INSTRUCTIONS FOR FILLING OUT N12A D11/1