

PUMP DATA	
DISPLACEMENT	45.0 ccm
MAX. PRESSURE	260 bar
SPEED RATE	500 TO 2600 rpm
MAX. INPUT SHAFT TORQUE	460 Nm
ROTATION	CLOCKWISE

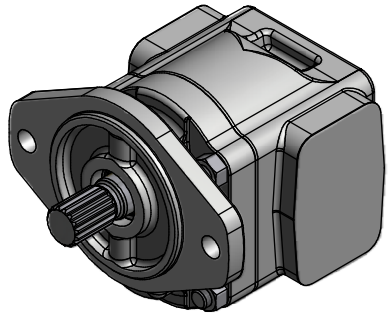

SAE INVOLUTE SPLINE  
15 TEETH - 16/32 PITCH  
FLAT ROOT SIDE FIT  
MAJOR DIA. 24.87 - 24.97  
MINOR DIA. 21.793 MAX.

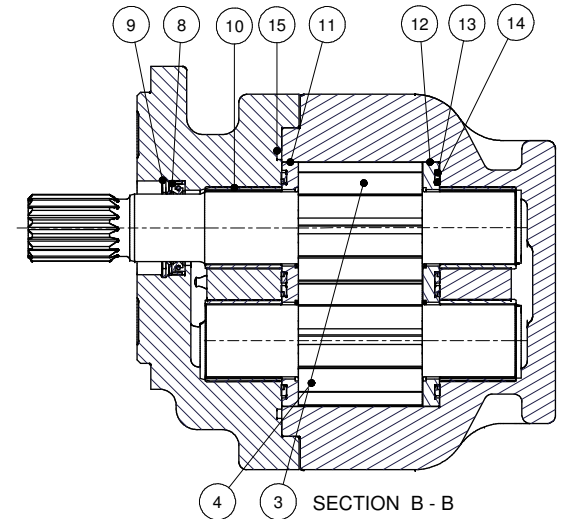
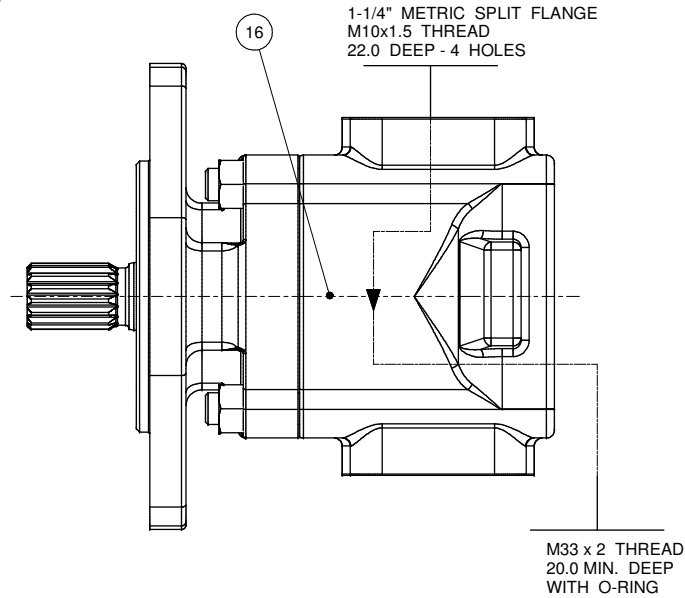
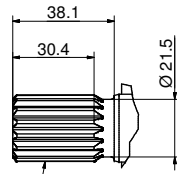

NOTE

- 1 FOR ASSEMBLY INSTRUCTIONS SEE DWG. NO. "625-B1" "PGP625 PUMP ASSEMBLY INSTRUCTIONS".
- 2 NAMEPLATE LOCATION MAY VARY DUE TO DESIGN CRITERIA OR MANUFACTURING LOCATION.

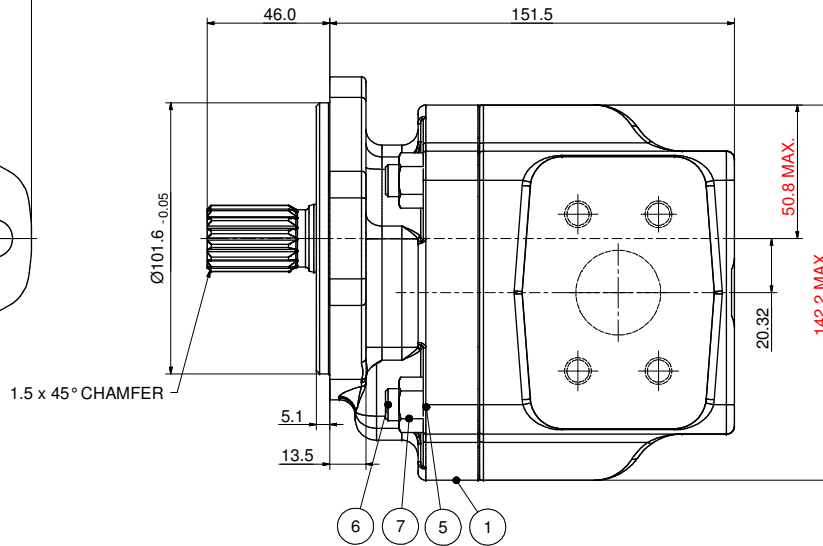
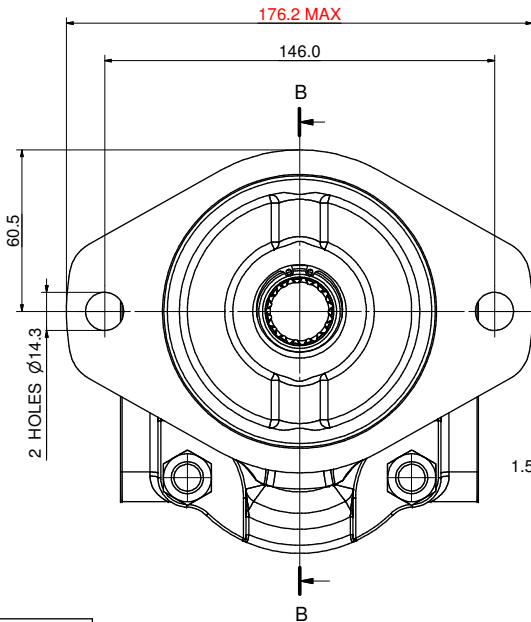

ITEM	PART NO	REQ'D	DESCRIPTION
16	391 2183 396	1	IDENTIFICATION STICKER
15	9312-641-004	1	SECTION SEAL
14	391 2882 162	2	SEAL. BK - UP
13	391 2882 161	2	SEAL. CHAN.
12	391 2185 152	1	BALANCE PLATE
11	391 2185 151	1	BALANCE PLATE
10	391 0482 203	4	BUSHING
9	9211-530-006	1	CIRCLIP
8	8682-119-00W	1	SEAL LIP.
7	391 1451 149	4	M12 NUT
6	8682-007-00M	4	FASTENER M12
5	9222-575-009	4	WASHER
4	705 2745 000	1	DRIVEN GEAR
3	705 1245 800	1	DRIVE GEAR
2	705 8945 001	1	BODY
1	705 5121 000	1	FLANGE

THIRD ANGLE PROJECTION
EXP. NO.
FIRST USED
12-01-628
705 9111 009

WITH EXCEPTION OF DRIVE SHAFT, FLANGE SPIGOT AND MTG. FACE PLUS AREAS AROUND PORTS ALL SURFACES ARE PAINTED BLACK ZSS - A1 (AA-O-05.2)

MATERIAL	ADM CTR	P	TOLERANCES UNLESS OTHERWISE SPECIFIED	DR BY	DATE	CHK BY	DATE	SCALE
			WHOLE NUMBER - REF. DIMENSIONS	TG	25JAN12	JS	25JAN12	
			1 PLACE DECIMALS	705 9111 009				
			2 PLACE DECIMALS					
			3 PLACE DECIMALS					
			4 PLACE DECIMALS					
			5 PLACE DECIMALS					
			6 PLACE DECIMALS					
			7 PLACE DECIMALS					
			8 PLACE DECIMALS					
			9 PLACE DECIMALS					
			10 PLACE DECIMALS					
			11 PLACE DECIMALS					
			12 PLACE DECIMALS					
			13 PLACE DECIMALS					
			14 PLACE DECIMALS					
			15 PLACE DECIMALS					
			16 PLACE DECIMALS					
			17 PLACE DECIMALS					
			18 PLACE DECIMALS					
			19 PLACE DECIMALS					
			20 PLACE DECIMALS					
			21 PLACE DECIMALS					
			22 PLACE DECIMALS					
			23 PLACE DECIMALS					
			24 PLACE DECIMALS					
			25 PLACE DECIMALS					
			26 PLACE DECIMALS					
			27 PLACE DECIMALS					
			28 PLACE DECIMALS					
			29 PLACE DECIMALS					
			30 PLACE DECIMALS					
			31 PLACE DECIMALS					
			32 PLACE DECIMALS					
			33 PLACE DECIMALS					
			34 PLACE DECIMALS					
			35 PLACE DECIMALS					
			36 PLACE DECIMALS					
			37 PLACE DECIMALS					
			38 PLACE DECIMALS					
			39 PLACE DECIMALS					
			40 PLACE DECIMALS					
			41 PLACE DECIMALS					
			42 PLACE DECIMALS					
			43 PLACE DECIMALS					
			44 PLACE DECIMALS					
			45 PLACE DECIMALS					
			46 PLACE DECIMALS					
			47 PLACE DECIMALS					
			48 PLACE DECIMALS					
			49 PLACE DECIMALS					
			50 PLACE DECIMALS					
			51 PLACE DECIMALS					
			52 PLACE DECIMALS					
			53 PLACE DECIMALS					
			54 PLACE DECIMALS					
			55 PLACE DECIMALS					
			56 PLACE DECIMALS					
			57 PLACE DECIMALS					
			58 PLACE DECIMALS					
			59 PLACE DECIMALS					
			60 PLACE DECIMALS					
			61 PLACE DECIMALS					
			62 PLACE DECIMALS					
			63 PLACE DECIMALS					
			64 PLACE DECIMALS					
			65 PLACE DECIMALS					
			66 PLACE DECIMALS					
			67 PLACE DECIMALS					
			68 PLACE DECIMALS					
			69 PLACE DECIMALS					
			70 PLACE DECIMALS					
			71 PLACE DECIMALS					
			72 PLACE DECIMALS					
			73 PLACE DECIMALS					
			74 PLACE DECIMALS					
			75 PLACE DECIMALS					
			76 PLACE DECIMALS					
			77 PLACE DECIMALS					
			78 PLACE DECIMALS					
			79 PLACE DECIMALS					
			80 PLACE DECIMALS					
			81 PLACE DECIMALS					
			82 PLACE DECIMALS					
			83 PLACE DECIMALS					
			84 PLACE DECIMALS					
			85 PLACE DECIMALS					
			86 PLACE DECIMALS					
			87 PLACE DECIMALS					
			88 PLACE DECIMALS					
			89 PLACE DECIMALS					
			90 PLACE DECIMALS					
			91 PLACE DECIMALS					
			92 PLACE DECIMALS					
			93 PLACE DECIMALS					
			94 PLACE DECIMALS					
			95 PLACE DECIMALS					
			96 PLACE DECIMALS					
			97 PLACE DECIMALS					
			98 PLACE DECIMALS					
			99 PLACE DECIMALS					
			100 PLACE DECIMALS					

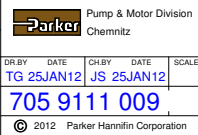

© 2012 Parker Hannifin Corporation