

PUMP DATA	
DISPLACEMENT	19,0 ccm
MAX. PRESSURE	190 bar
SPEED RATE	500 TO 2500 min ⁻¹
MAX. INPUT SHAFT TORQUE	144 Nm
ROTATION	CLOCKWISE

SEAL KIT
8682-023-00N

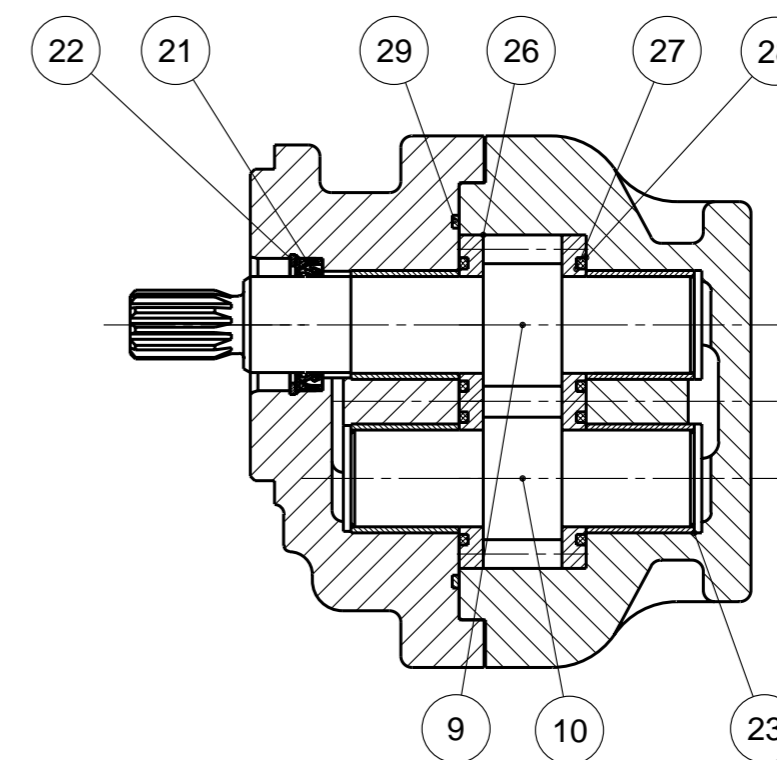
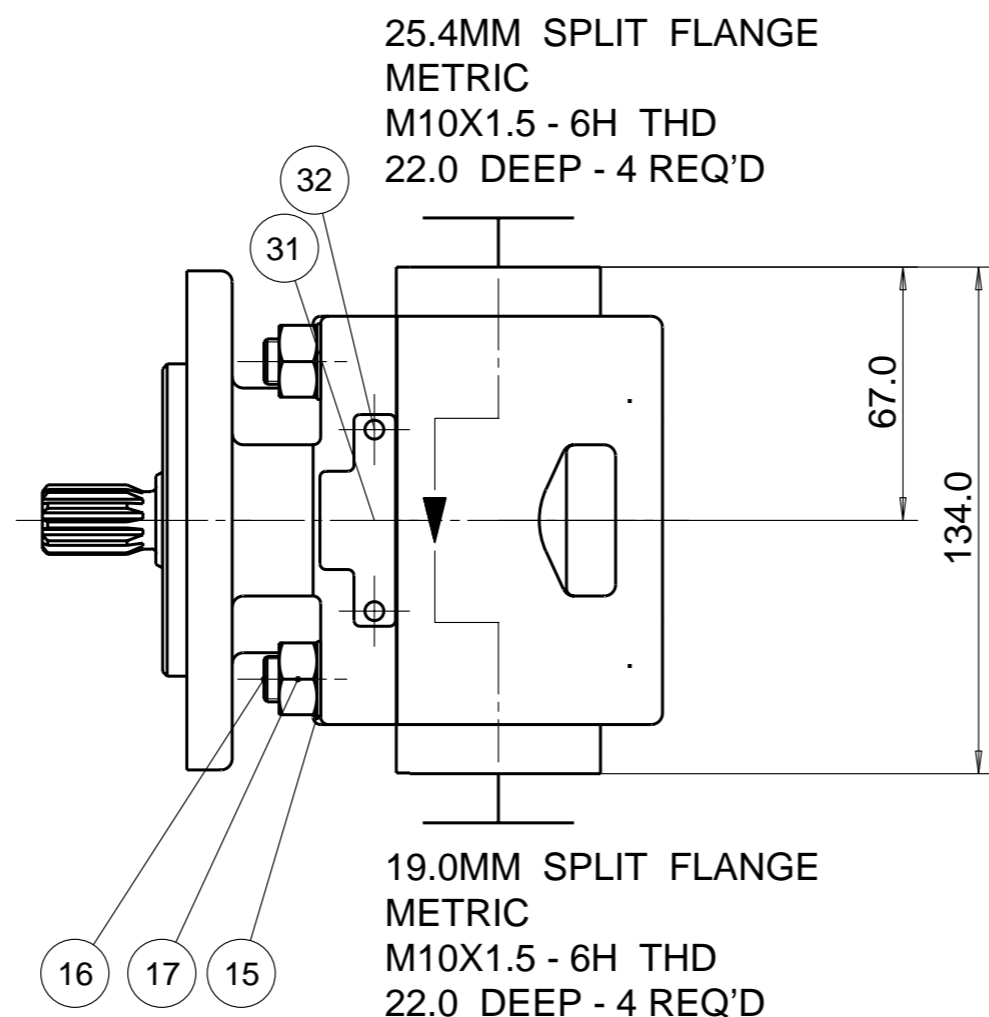
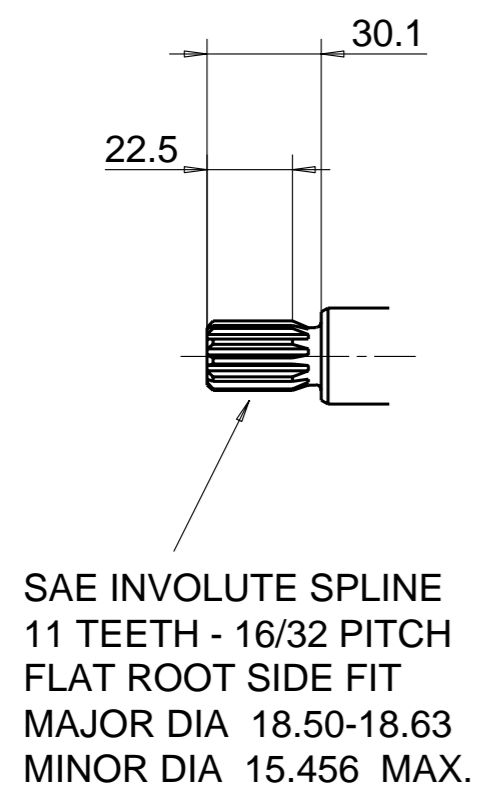

NOTE

- FOR ASSEMBLY INSTRUCTIONS SEE DWG. NO. "620-B1" "PGP620 PUMP ASSEMBLY INSTRUCTIONS".
- NAMEPLATE LOCATION MAY VARY DUE TO DESIGN CRITERIA OR MANUFACTURING LOCATION. STICKER OPTIONAL FOR #31 & #32

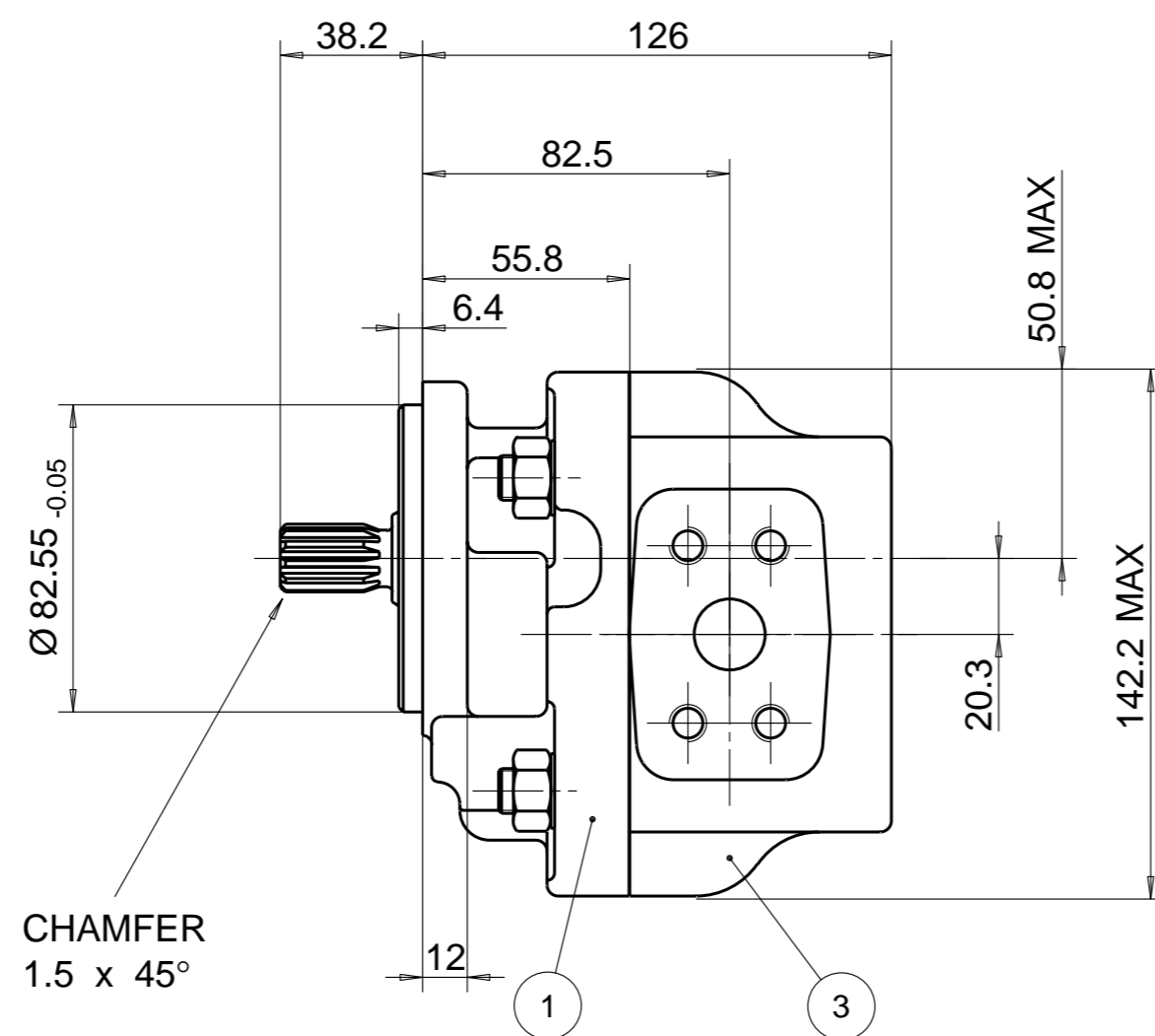
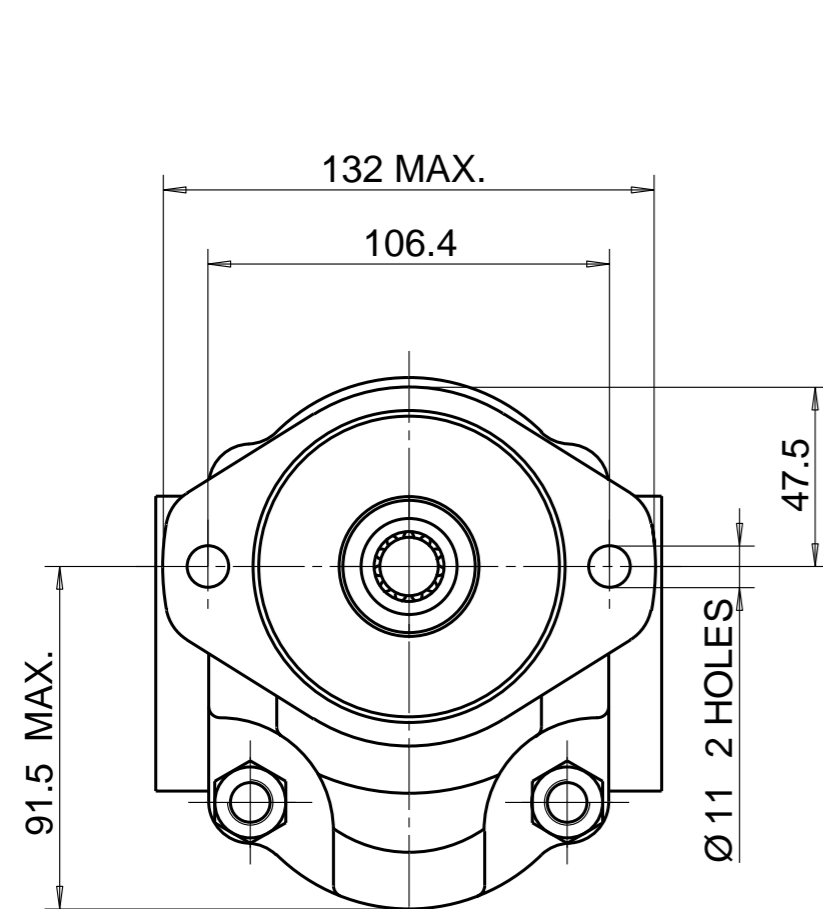

28	8682-015-00Q	2	SEAL. ELEM.	36		
27	8682-016-00L	2	SEAL. ENERG	35		
26	391 2185 150	2	BAL. PLATE	34		
25				33		
24				32	391 1432 004	2 SCREW. DR.
23	391 0482 237	4	BUSH	31	391 2183 227	1 NAMEPLATE
22	9211-530-006	1	CIRCLIP	30		
21	8682-019-00Z	1	SEAL. LIP	29	9312-641-004	1 SEAL. SECT.
ITEM	PART NO	REQD		ITEM	PART NO	REQD

20						
19						
18						
17	391 1451 149	4	M12 NUT			
16	8682-007-00M	4	M12 SCREW			
15	9222-575-009	4	WASHER			
14						
13						
12						
11						
10	702 2719 000	1	DRIVEN GEAR			
9	702 1219 300	1	DRIVE GEAR			
8						
7						
6						
5						
4						
3	702 8119 518	1	BODY			
2						
1	2PRF03A1B	1	FLANGE			
ITEM	PART NO	REQ'D		DESCRIPTION		

WITH EXCEPTION OF DRIVE SHAFT, FLANGE SPIGOT AND MTG. FACE PLUS AREAS AROUND PORTS, ALL SURFACES ARE PAINTED BLACK ZSS - A1 (AA-O-05.2)

THIRD ANGLE PROJECTION

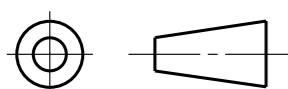

EXP NO.

FIRST USED

15 - 06 - 632

702 9111 322

SYM.

REVISIONS

THIS DOCUMENT CONTAINS INFORMATION THAT IS CONFIDENTIAL AND PROPRIETARY TO PARKER-HANNIFIN CORPORATION ("PARKER"). THIS DOCUMENT IS FURNISHED ON THE UNDERSTANDING THAT THE DOCUMENT AND THE INFORMATION IT CONTAINS WILL NOT BE COPIED OR DISCLOSED TO OTHERS OR USED FOR ANY PURPOSE OTHER THAN CONDUCTING BUSINESS WITH PARKER, AND WILL BE RETURNED AND ALL FURTHER USE DISCONTINUED UPON REQUEST BY PARKER. ALL RIGHTS RESERVED.

PGP620A0190CC1H2NT3T2B1B1

MATERIAL

ADM CTR P
REV DTE 000000

H.E.-STD:

WT 12.1 kg

DIMENSIONS ARE MM

Parker Pump & Motor Division
Chemnitz

DR.BY DATE CH.BY DATE SCALE
AS 24JUN15 JS 24JUN15 1/2

702 9111 322

© 2015 Parker Hannifin Corporation