



Bulletin MSG30-3207/EU



Visit our homepage for additional support
parker.com/pmde

Torqmotor™ Service

Langsamlaufender Hydraulik-Motor
Low speed hydraulic motor
Moteur lent système hydraulique
Motore idraulico a bassa velocità

Effective: March 06, 2018
Supersedes: July 02, 2012

Torqmotor

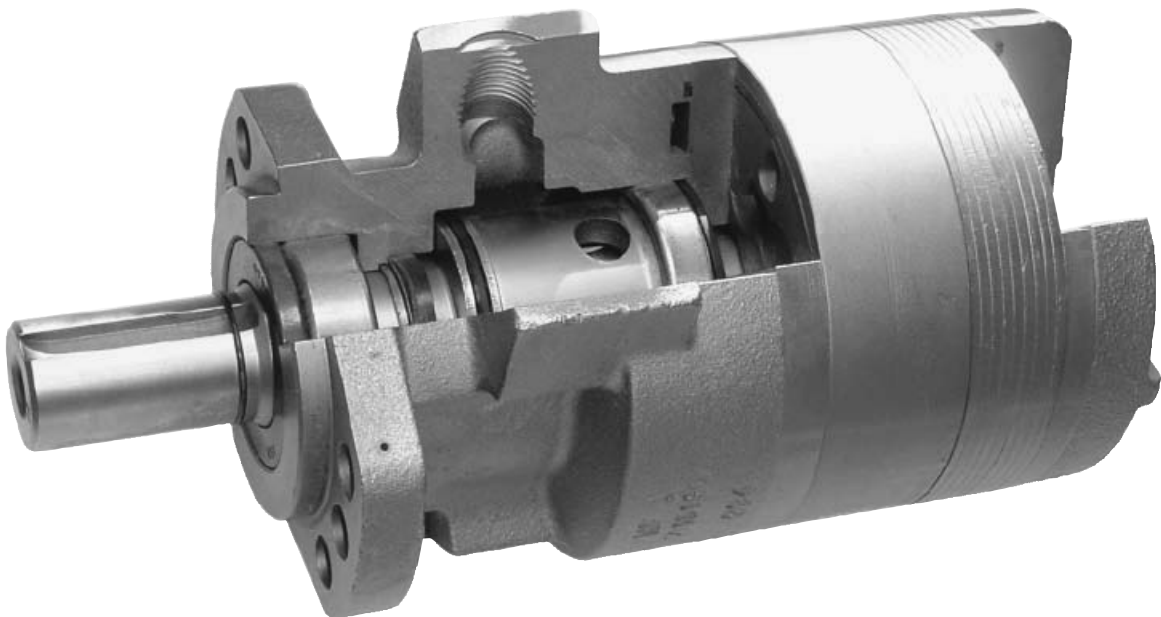

DE Hinweis

Die in diesem Katalog oder in Form anderer Informationen durch die Parker Hannifin GmbH, ihre Niederlassungen, Vertriebsbüros oder ihre autorisierten Werksvertretungen gemachten Angaben sind für Anwender mit Sachkenntnissen bestimmt. Vom Anwender ist eine Überprüfung der über das ausgewählte Produkt gemachten Angaben auf Eignung für die geforderten Funktionen erforderlich. Bedingt durch die unterschiedlichen Aufgaben und Arbeitsabläufe in einem System muss der Anwender prüfen und sicherstellen, dass durch die Eigenschaften des Produkts alle Forderungen hinsichtlich Funktion und Sicherheit des Systems erfüllt werden.

UK Note

This document and other information from Parker Hannifin GmbH, its subsidiaries, sales offices and authorized distributors provide product or system options for further investigation by users having technical expertise. Before you select or use any product or system it is important that you analyse all aspects of your application and review the information concerning the product or system in the current product catalogue. Due to the variety of operating conditions and applications for these products or systems, the user, through his own analysis and testing, is solely responsible for making the final selection of the products and systems and assuring that all performance and safety requirements of the application are met. The products are subject to change by Parker Hannifin GmbH at any time without notice.

FR Note



Les indications données dans le présent catalogue ainsi que toutes autres informations fournies par Parker Hannifin GmbH, ses succursales, ses bureaux de vente ou ses représentations d'usine autorisées sont destinées aux utilisateurs ayant des connaissances techniques en la matière. L'utilisateur devra procéder à une vérification des indications faites sur le produit sélectionné pour savoir s'il est bien approprié aux fonctions demandées. Dû aux conditions environnementales variées dans les quelles ces composants et ces systèmes doivent opérer, l'utilisateur doit vérifier et s'assurer que les propriétés du produits répondent bien à toutes les exigences relatives au fonctionnement et à la sécurité du système.

IT Avvertenza

Le indicazioni fatte nel presente catalogo o sotto forma di altre informazioni dalla Parker Hannifin GmbH, dalle sue filiali, uffici di vendita o dalle sue consociate autorizzate, sono destinate a utenti con conoscenze tecniche. L'utente è tenuto a verificare che le indicazioni fatte sul prodotto scelto siano conformi alle funzioni richieste. A causa delle diverse applicazioni e condizioni d'impiego, l'utente deve verificare e assicurare che le proprietà del prodotto soddisfino tutte le esigenze relative al funzionamento e alla sicurezza del sistema.

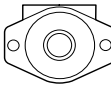
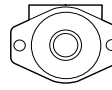

Contents

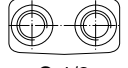
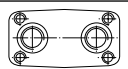
Description DE	UK	FR	IT	Page
Ersatzteile TE	Spare parts TE	Pièces de rechange TE	Pezzi di ricambio TE	4
Montage TE	Assembly TE	Assemblage TE	Assemblaggio TE	5
Ersatzteile TJ	Spare parts TJ	Pièces de rechange TJ	Pezzi di ricambio TJ	6
Montage TJ	Assembly TJ	Assemblage TJ	Assemblaggio TJ	7
Ersatzteile TF	Spare parts TF	Pièces de rechange TF	Pezzi di ricambio TF	8
Montage TF	Assembly TF	Assemblage TF	Assemblaggio TF	9
Ersatzteile TL	Spare parts TL	Pièces de rechange TL	Pezzi di ricambio TL	10
Montage TL	Assembly TL	Assemblage TL	Assemblaggio TL	11
Ersatzteile TG	Spare parts TG	Pièces de rechange TG	Pezzi di ricambio TG	12
Montage TG	Assembly TG	Assemblage TG	Assemblaggio TG	13
Ersatzteile TH	Spare parts TH	Pièces de rechange TH	Pezzi di ricambio TH	14
Montage TH	Assembly TH	Assemblage TH	Assemblaggio TH	15
Betriebsempfehlung	Operating recom- mendation	Instructions de mise en service	Consigli d'impiego	16

Pos. 1				
Gehäuse komplett Housing assembly Carter Scatola motore				
	MF012237J3 CODE CW	MF012256J3 CODE MW	MF012231J3 CODE DW	MF012260J3 CODE LW
	MF012253J3 CODE CN	MF012252J3 CODE MN	MF012254J3 CODE DN	-----
Endanschluss Rear port Orifices arrière Alim. laterale	MF012032J3 CODE CY	MF012021J3 CODE MY	MF012033J3 CODE DY	MF012041J3 CODE LY

Pos. 6	
Dichtsatz komplett Seal kit Jeu de joints Kit guarnizioni	SK000090 Standard
Dichtsatz komplett Seal kit Jeu de joints Kit guarnizioni	SK000091 FPM
Dichtsatz komplett Seal kit Jeu de joints Kit guarnizioni	SK000100 Vespel

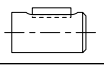
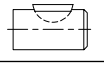
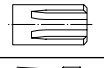
Pos. 9	
Zwischenscheibe Wear plate Plaque d'usure Piastra d'usura	477376

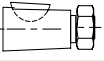
Pos. 2			Pos. 14	
Abtriebswelle / Coupling shaft Arbre / Albero uscita			Passfeder / Key Clavette / Chiavetta	Scheibenfeder Woodruff key Clavette / Chia- vetta
	Ø 25.00	MF 019 012 CODE 26	52510700	-----
	Ø 25.40	MF 019 006 CODE 10	-----	G124553
	6B SAE	MF 019 024 CODE 41	-----	-----
	1:8 25.4 mm	MF 019 004 CODE 12	-----	G124553
	1:8 35.0 mm	MF 019 011 CODE 25	-----	G124553

Pos. 10		
Verteiler Manifold Plan de pose Distributore	TE015000 Standard	CODE 0
Verteiler Manifold Plan de pose Distributore	TE015001 Reverse	CODE 1

Pos. 12	
Kommutator komplett Commutator assembly Ensemble commutateur Assieme distributore	TE018000A1
Für Endanschluss For rear port Pour orifices arrière Per alimentazione laterale	TE018001A1

	Pos. 3	Pos. 4	Pos. 5
Baugröße Size Taille Grandezza	Schraube / Bolt Vis / Vite	Rotor komplett Rotor set Jeu rotor Rotore	Zwischenwelle Drive link Abre d'entrain Albero entrata
36	021311	TE017003	MF013000
45	021311	TE027003	MF023000
50	021311	TE037003	MF033000
65	021306	TE047003	MF043000
80	021382	TE057003	MF053000
100	021357	TE067003	MF063000
130	021307	TE087003	MF083000
165	021358	TE107003	MF103000
195	021308	TE127003	MF123000
230	021359	TE147003	MF143000
260	021310	TE167003	MF163000
295	021383	TE187003	MF183000
330	021384	TE207003	MF203000
390	021414	TE247003	MF243000

Pos. 13		
Abschlussplatte End cover Couvercle Coperchio post.	TE016000 Standard	
Für Endanschluss For rear port Pour orifices arrière Per alimentazione laterale	TE016005 G 1/2 Axial	CODE Y

Pos. 15	
Selbstsichernde Mutter Self-locking nut Ecrrou nyl-stop Dado autobloccante	025136
Kronenmutter Castle nut Ecrrou crénéle Tuerca	025156

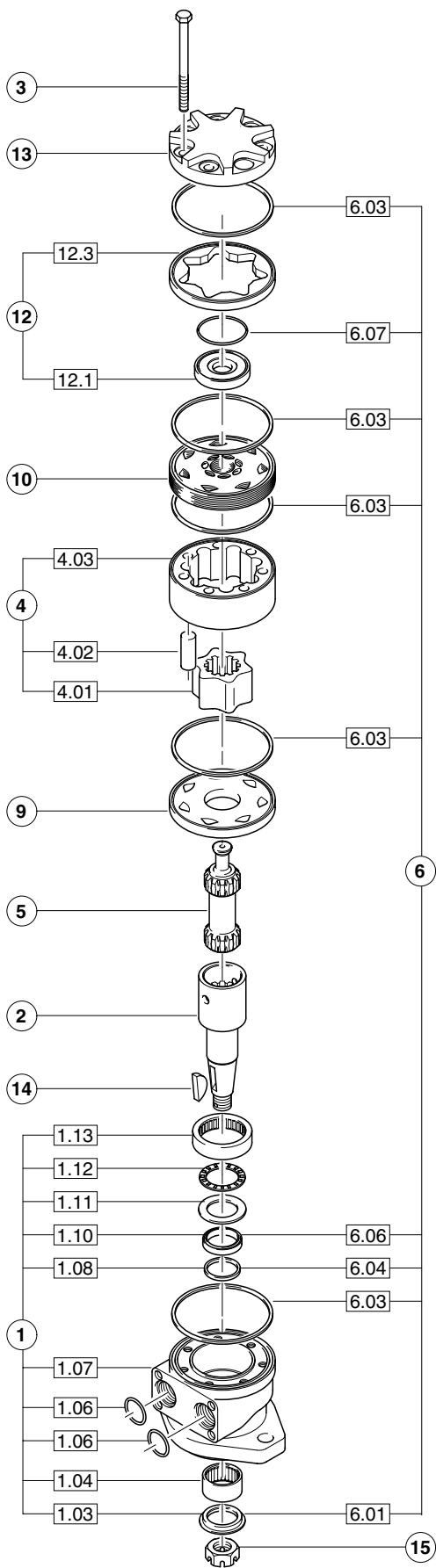

Kommutator komplett mit neuer Dichtung einsetzen. Die flache Seite der Dichtung zeigt nach außen.

Fit commutator assembly with new seals. Assemble seal flat side out.

Remonter l'ensemble commutateur avec un nouveau joint côté plat à l'extérieur.

Montare il distributore con la nuova guarnizione con il lato piano verso l'esterno.

30...35Nm Anziehmoment wechselseitig an 5 oder 6 Schrauben.

30...35Nm torque max. 5 or 6 bolts crosswise.

30...35Nm couple moteur max. 5 ou 6 boulons réciproquement.

30...35Nm coppia di serraggio 5 o 6 bulloni.

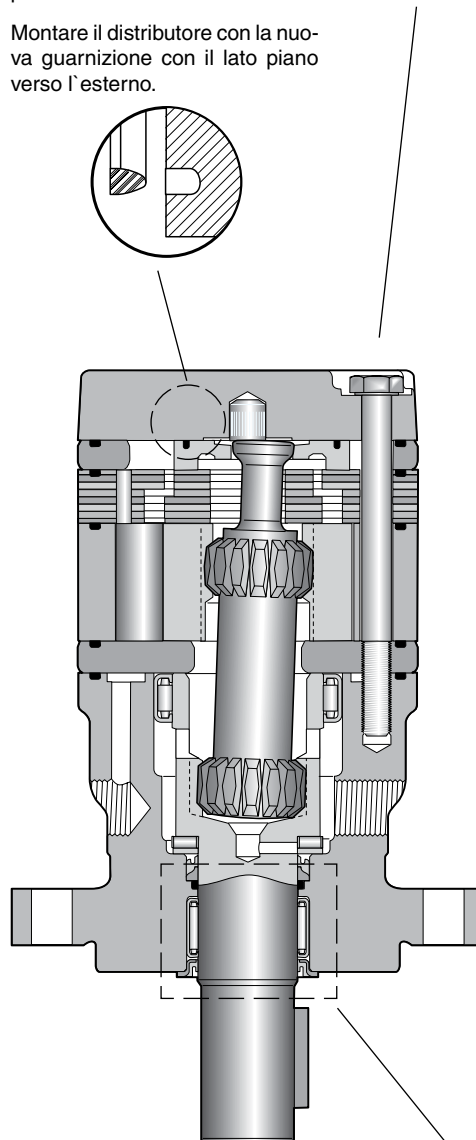

Vor dem Einbau der Abtriebswelle den Raum zwischen den gestrichelten Linien befeuchten.

Apply grease to shaft OD. and ID. in area designated by dotted lines.

Avant l'assemblage de l'arbre veuillez graisser l'espace situé entre les lignes en tirets.

Prima del montaggio dell'albero pregasi lubrificare la zona evidenziata con linee tratteggiate.

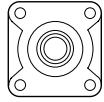
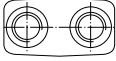
Pos. 1	
Gehäuse komplett Housing assembly Carter Scatola motore	
	MP012003J3 CODE UW
G 1/2	

Pos. 6	
Dichtsatz komplett Seal kit Jeu de joints Kit guarnizioni	SK000146 Standard

Pos. 9	
Zwischenscheibe Wear plate Plaque d'usure Piastra d'usura	477376

Pos. 2			Pos. 14
Abtriebswelle / Coupling shaft Arbre / Albero uscita			Scheibenfeder Woodruff key Clavette / Chiavetta
	1:8 1.25 inch	MP019000 CODE 08	G124554

Pos. 10		
Verteiler Manifold Plan de pose Distributore	TE015000 Standard	CODE 0
Verteiler Manifold Plan de pose Distributore	TE015001 Reverse	CODE 1

	Pos. 3	Pos. 4	Pos. 5
Baugröße Size Taille Grandezza	Schraube / Bolt Vis / Vite	Rotor komplett Rotor set Jeu rotor Rotore	Zwischenwelle Drive link Arbre d'entrain Albero entrata
36	021311	TE017003	MF013000
45	021311	TE027003	MF023000
50	021311	TE037003	MF033000
65	021306	TE047003	MF043000
80	021382	TE057003	MF053000
100	021357	TE067003	MF063000
130	021307	TE087003	MF083000
165	021358	TE107003	MF103000
195	021308	TE127003	MF123000
230	021359	TE147003	MF143000
260	021310	TE167003	MF163000
295	021383	TE187003	MF183000
330	021384	TE207003	MF203000
390	021414	TE247003	MF243000

Pos. 12	
Kommutator komplett Commutator assembly Ensemble commutateur Assieme distributore	TE018000A1

Pos. 13	
Abschlussplatte End cover Couvercle Coperchio post.	TE016000

Pos. 15	
Selbstsichernde Mutter Self-locking nut Ecrou nyl-stop Dado autobloccante	025126
Kronenmutter Castle nut Ecrou crénéle Tuerca	025132

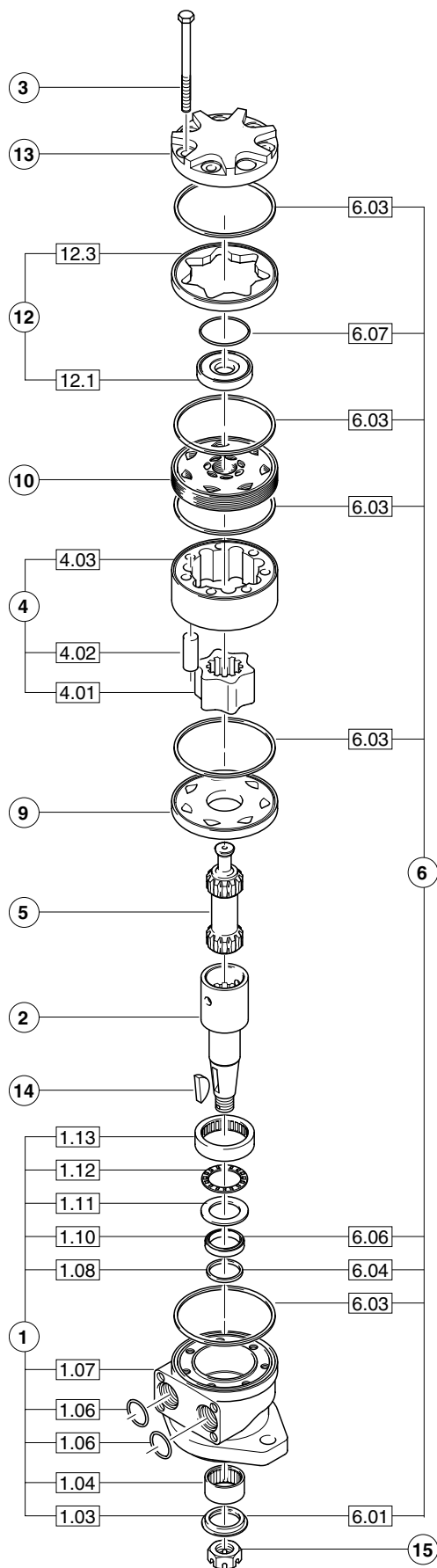

Kommutator komplett mit neuer Dichtung einsetzen. Die flache Seite der Dichtung zeigt nach außen.

Fit commutator assembly with new seals. Assemble seal flat side out.

Remonter l'ensemble commutateur avec un nouveau joint côté plat à l'extérieur.

Montare il distributore con la nuova guarnizione con il lato piano verso l'esterno.

30...35Nm Anziehmoment wechselseitig an 5 oder 6 Schrauben.

30...35Nm torque max. 5 or 6 bolts crosswise.

30...35Nm couple moteur max. 5 ou 6 boulons réciproquement.

30...35Nm coppia di serraggio 5 o 6 bulloni.

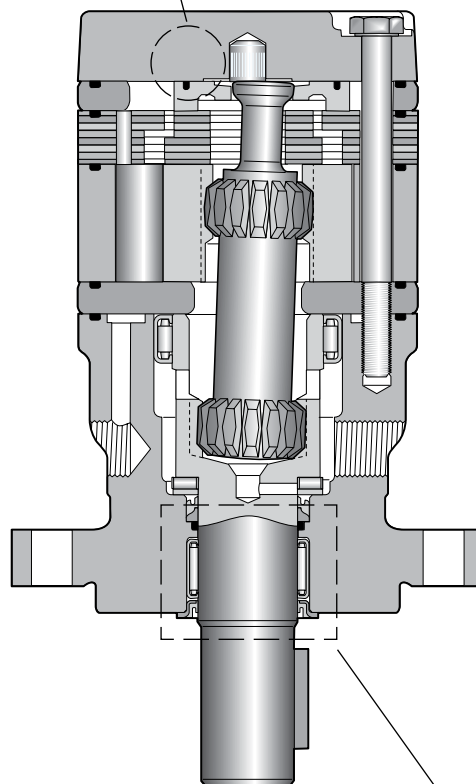
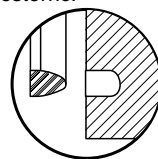









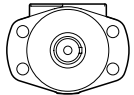
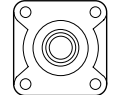

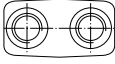
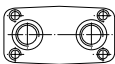
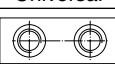
Vor dem Einbau der Abtriebswelle den Raum zwischen den gestrichelten Linien befeuchten.

Apply grease to shaft OD. and ID. in area designated by dotted lines.

Avant l'assemblage de l'arbre veuillez graisser l'espace situé entre les lignes en tirets.

Prima del montaggio dell'albero pregasi lubrificare la zona evidenziata con linee tratteggiate.

Pos. 1				
Gehäuse komplett Housing assembly Carter Scatola motore				
	ME012015J3 CODE EW	ME012041J3 CODE MW	ME012032J3 CODE HW	-----
	ME012037J3 CODE EN	ME012039J3 CODE MN	ME012030J3 CODE HK	-----
	ME012034J3 CODE EV	ME012038J3 CODE MV	ME012042J3 CODE HV	-----
Endanschluss Rear port Orifices arrière Alim. laterale	ME012036J3 CODE E*	ME012004J3 CODE M*	ME012055J3 CODE H*	ME012049J3 CODE V*

Pos. 2			Pos. 14	
Abtriebswelle / Coupling shaft Arbre / Albero uscita			Passfeder / Key Clavette / Chiavetta	Scheibenfeder Woodruff key Clavette / Chiavetta
	Ø 25.00	MB019017* CODE 26	52510700	-----
	Ø 25.40	MB019014* CODE 47	-----	G124553
	6B SAE	MB019013* CODE 41	-----	-----
	Ø 31.75	MB019015* CODE 45	52530507	-----
	1:8 1.25 inch	MB019000* CODE 08	-----	G124554
	Ø 32.00	MB019016* CODE 46	039044	-----
	12/24 pitch 14 teeth	MB019024* CODE 44	-----	-----

* Shafts only until 280cc - otherwise use TG shafts !

	Pos. 3		Pos. 4	Pos. 5
Baugröße Size Taille Grandezza	Schraube / Bolt Vis / Vite	Für Endanschluss For rear port Pour orifices arrière Per alimentazione laterale	Rotor komplett Rotor set Jeu rotor Rotore	Zwischenwelle Drive link Abre d'entrain Albero entrata
80	021271	021386	MB057003	MB063000
100	021271	021386	MB067003	MB063000
130	021271	021273	MB087003	MB083000
140	021390	021273	MB097003	MB093000
170	021376	021387	MB107003	MB103000
195	021352	021379	MB127003	MB123000
240	021272	021291	MB157003	MB153000
280	021340	021392	MB187003	MB183000
360	021387	021366	ME237003	ME233000
405	021379	021415	ME247003	ME243000
475	021392	021394	ME297003	ME293000

Pos. 6	
Dichtsatz komplett Seal kit Jeu de joints Kit guarnizioni	SK000092

Pos. 8	
Axiallager Thrust bearing Roulement Cuscinetto reggispinta	068024

Pos. 9	
Zwischenscheibe Wear plate Plaque d'usure Piastra d'usura	477342

Pos. 10		
Verteiler Manifold Plan de pose Distributore	ME015000 Standard	CODE 0
Verteiler Manifold Plan de pose Distributore	ME015001 Reverse	CODE 1

Pos. 12	
Kommutator komplett Commutator assembly Ensemble commutateur Assieme distributore	ME018000A1
Für Endanschluss For rear port Pour orifices arrière Per alimentazione laterale	ME018001A1

Pos. 13		
Abschlussplatte / End cover Couvercle / Coperchio posteriore ME016000 Standard		
Für Endanschluss / For rear port Pour orifices arrière Per alimentazione laterale		
ME016009	7/8-14 UNF Axial	CODE A
ME016002	7/8-14 UNF Radial	CODE B
ME016007	Universal	CODE L
ME016010	G 1/2 Radial	CODE X
ME016011	G 1/2 Axial	CODE Y

Pos. 15	
Selbstsichernde Mutter Self-locking nut Ecrou nyl-stop Dado autobloccante	025126
Kronenmutter Castle nut Ecrou crénelé Tuerca	025132

Pos. 16	
Wellenring Circlip Circlips Anello seeger	401333

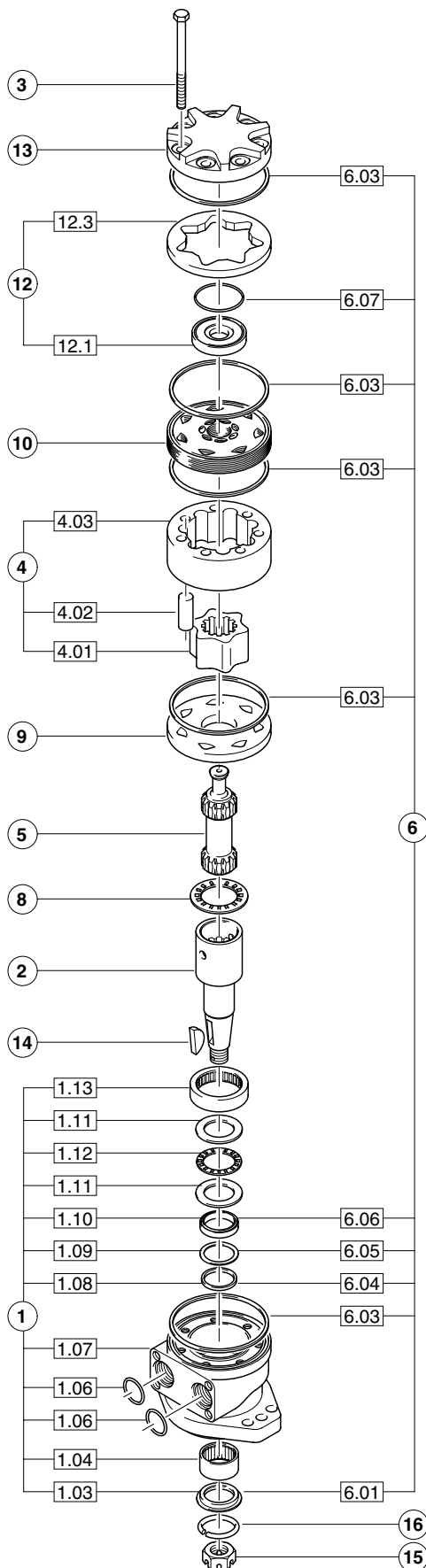

61...75Nm Anziehmoment wechselseitig an 7 Schrauben.

61...75Nm torque max. 7 bolts crosswise.

61...75Nm couple moteur max. 7 boulons réciproquement.

61...75Nm coppia di serraggio 7 bulloni.

Kommutator komplett mit neuer Dichtung einsetzen. Die flache Seite der Dichtung zeigt nach außen.

Fit commutator assembly with new seals. Assemble seal flat side out.

Remonter l'ensemble commutateur avec un nouveau joint côté plat à l'extérieur.

Montare il distributore con la nuova guarnizione con il lato piano verso l'esterno.

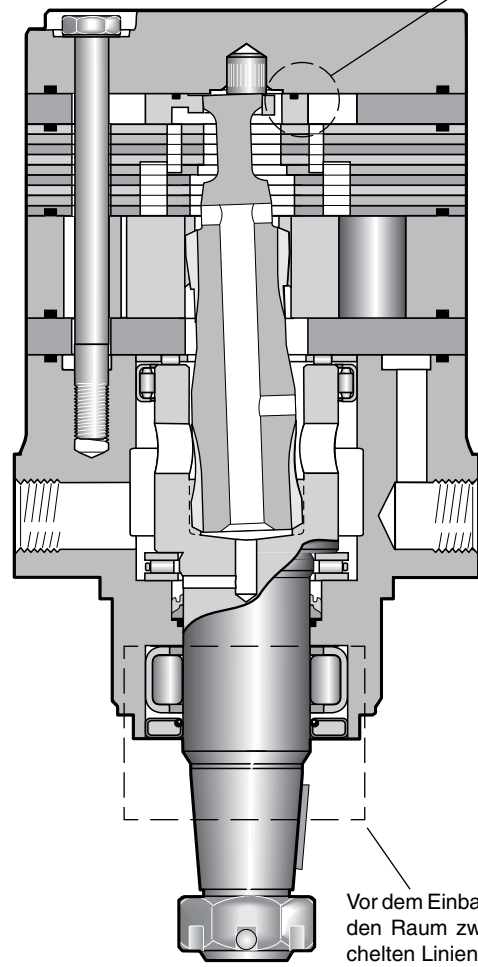
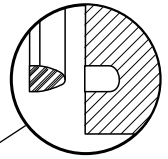

Vor dem Einbau der Abtriebswelle den Raum zwischen den gestrichelten Linien befeuchten.

Apply grease to shaft OD. and ID. in area designated by dotted lines.

Avant l'assemblage de l'arbre veuillez graisser l'espace situé entre les lignes en tirets.

Prima del montaggio dell'albero pregasi lubrificare la zona evidenziata con linee tratteggiate.

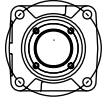
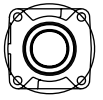
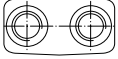
Pos. 1		
Gehäuse komplett Housing assembly Carter Scatola motore		
	TL012001J4 CODE LS	TL012000J4 CODE US
7/8-14 SAE		

Pos. 6	
Dichtsatz komplett Seal kit Jeu de joints Kit guarnizioni	SK000092 Standard

Pos. 9	
Zwischenscheibe Wear plate Plaque d'usure Piastra d'usura	477342*

*477014 for TL0140; 477366 for TL0170

Pos. 2		Pos. 14	
Abtriebswelle / Coupling shaft Arbre / Albero uscita		Scheibenfeder Woodruff key Clavette / Chiavetta	
	1:8 1.25 inch	TL019000 CODE 08	G124554

Pos. 10		
Verteiler Manifold Plan de pose Distributore	TL015000 Standard	CODE 0
Verteiler Manifold Plan de pose Distributore	TL015001 Reverse	CODE 1

	Pos. 3	Pos. 4	Pos. 5
Baugröße Size Taille Grandezza	Schraube / Bolt Vis / Vite	Rotor komplett Rotor set Jeu rotor Rotore	Zwischenwelle Drive link Arbre d'entrain Albero entrata
140	021271	ME097003	TL123000
170	021271	TL107003	TL123000
195	021271	TL127003	TL123000
240	021390	TL157003	TL153001
280	021352	ME187003	TL183000
310	021272	TL197003	TL193000
360	021340	TL237003	TL233000

Pos. 12	
Kommutator komplett Commutator assembly Ensemble commutateur Assieme distributore	ME018000A1

Pos. 13	
Abschlussplatte End cover Couvercle Coperchio post.	ME016000

Pos. 15	
Selbstsichernde Mutter Self-locking nut Ecrou nyl-stop Dado autobloccante	025126
Kronenmutter Castle nut Ecrou crèné Tuerca	025132

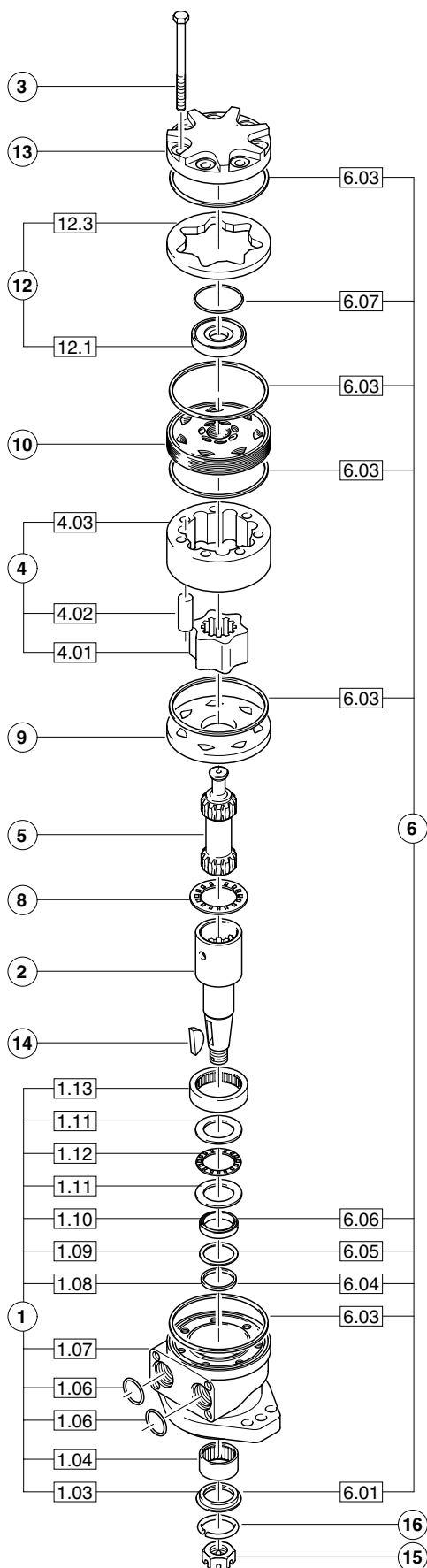

61...75Nm Anziehmoment wechselseitig an 7 Schrauben.

61...75Nm torque max. 7 bolts crosswise.

61...75Nm couple moteur max. 7 boulons réciproquement.

61...75Nm coppia di serraggio 7 bulloni.

Kommutator komplett mit neuer Dichtung einsetzen. Die flache Seite der Dichtung zeigt nach außen.

Fit commutator assembly with new seals. Assemble seal flat side out.

Remonter l'ensemble commutateur avec un nouveau joint côté plat à l'extérieur.

Montare il distributore con la nuova guarnizione con il lato piano verso l'esterno.

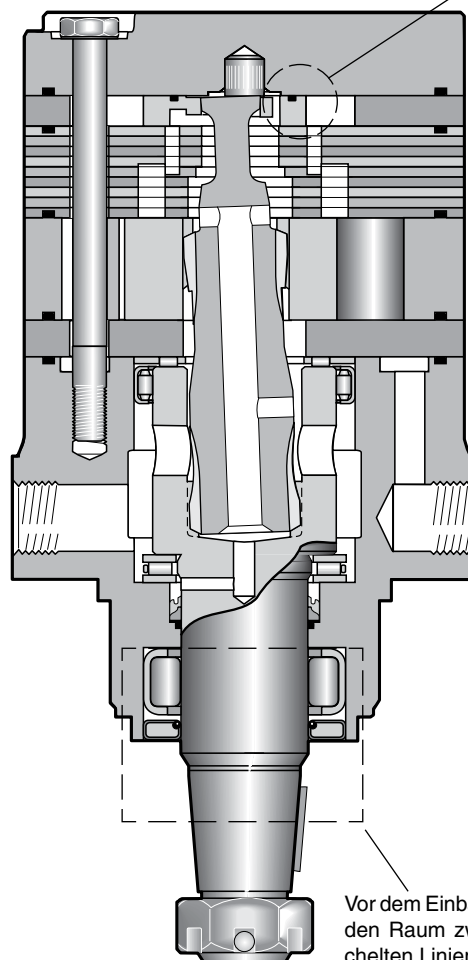
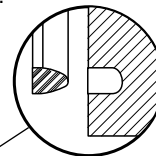

Vor dem Einbau der Abtriebswelle den Raum zwischen den gestrichelten Linien be fetten.

Apply grease to shaft OD. and ID. in area designated by dotted lines.

Avant l'assemblage de l'arbre veuillez graisser l'espace situé entre les lignes en tirets.

Prima del montaggio dell'albero pregasi lubrificare la zona evidenziata con linee tratteggiate.

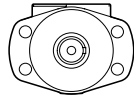
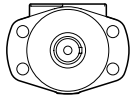
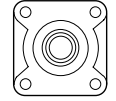
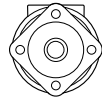
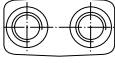
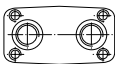
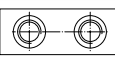
Pos. 1				
Gehäuse komplett Housing assembly Carter Scatola motore				
 G 1/2	ME012015J4 CODE EW	ME012041J4 CODE MW	ME012032J4 CODE HW	-----
 Universal	ME012037J4 CODE EN	ME012039J4 CODE MN	ME012030J4 CODE HK	-----
 7/8 UNF	ME012034J4 CODE EV	ME012038J4 CODE MV	ME012042J4 CODE HV	-----
Endanschluss Rear port Orifices arrière Alim. laterale	ME012036J4 CODE E*	ME012004J4 CODE M*	ME012055J4 CODE H*	ME012049J4 CODE V*

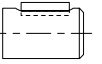
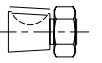
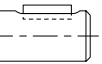
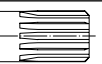
Pos. 2			Pos. 14	
Abtriebswelle / Coupling shaft Arbre / Albero uscita			Passfeder / Key Clavette / Chiavetta	Scheibenfeder Woodruff key Clavette / Chiavetta
	Ø 31.75	ME019012 CODE 45	52530507	-----
	1:8 1.25 inch	ME019000 CODE 08	-----	G124554
	Ø 32.00	ME019024 CODE 46	039044	-----
	12/24 pitch 14 teeth	ME019013 CODE 44	-----	-----

	Pos. 3		Pos. 4	Pos. 5
Baugröße Size Taille Grandezza	Schraube / Bolt Vis / Vite	Für Endanschluss For rear port Pour orifices arrière Per alimentazione laterale	Rotor komplett Rotor set Jeu rotor Rotore	Zwischenwelle Drive link Abre d'entrain Albero entrata
140	021390	021273	ME097003	ME093000
170	021376	021387	ME107003	ME103000
195	021352	021379	ME127003	ME123000
240	021272	021291	ME157003	ME153000
280	021340	021392	ME187003	ME183000
335	021273	021385	ME217003	ME213000
405	021379	021415	ME247003	ME243000
475	021392	021394	ME297003	ME293000
530	021385	021393	ME337003	ME333000
625	021366	021329	ME377003	ME373000
785	021395	021388	ME487003	ME483000
960	021396	021389	ME587003	ME583000

Pos. 6	
Dichtsatz komplett Seal kit Jeu de joints Kit guarnizioni	SK000092

Pos. 8	
Axiallager Thrust bearing Roulement Cuscinetto reggispinta	068024

Pos. 9	
Zwischenscheibe Wear plate Plaque d'usure Piastra d'usura	477342

Pos. 10		
Verteiler Manifold Plan de pose Distributore	ME015000 Standard	CODE 0
Verteiler Manifold Plan de pose Distributore	ME015001 Reverse	CODE 1

Pos. 12	
Kommutator komplett Commutator assembly Ensemble commutateur Assieme distributore	ME018000A1
Für Endanschluss For rear port Pour orifices arrière Per alimentazione laterale	ME018001A1

Pos. 13		
Abschlussplatte / End cover Couvercle / Coperchio posteriore ME016000 Standard		
Für Endanschluss / For rear port Pour orifices arrière Per alimentazione laterale		
ME016009 ME016002 ME016007 ME016010 ME016011	7/8-14 UNF Axial 7/8-14 UNF Radial Universal G 1/2 Radial G 1/2 Axial	CODE A CODE B CODE L CODE X CODE Y

Pos. 15	
Selbstsichernde Mutter Self-locking nut Ecrou nyl-stop Dado autobloccante	025126
Kronenmutter Castle nut Ecrou crénelé Tuerca	025132

Pos. 16	
Wellenring Circlip Circlips Anello seeger	401333

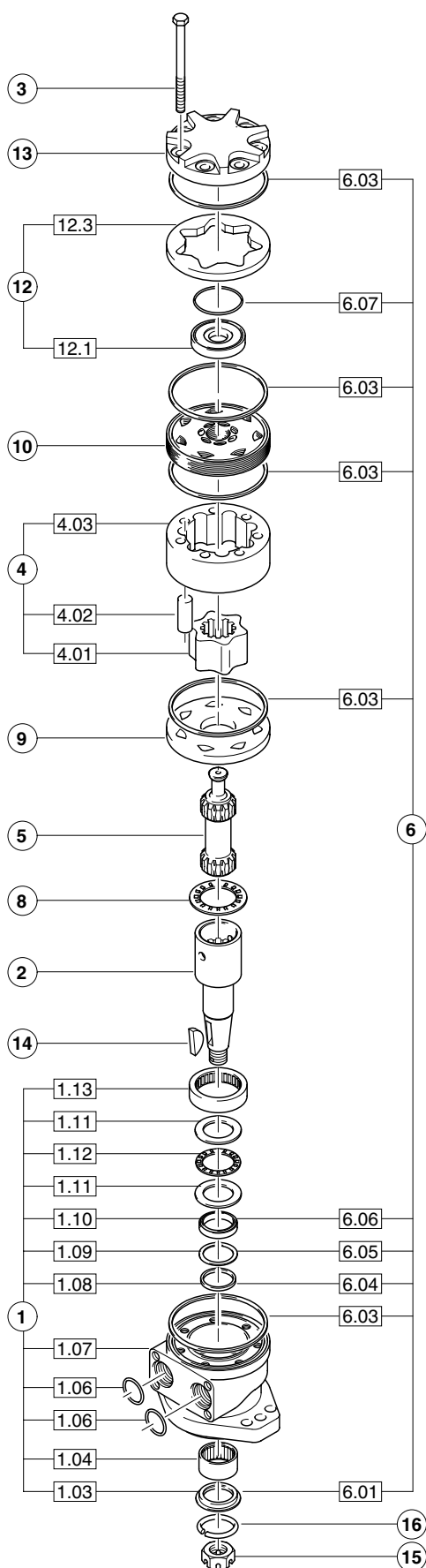

61...75Nm Anziehmoment wechselseitig an 7 Schrauben.

61...75Nm torque max. 7 bolts crosswise.

61...75Nm couple moteur max. 7 boulons réciproquement.

61...75Nm coppia di serraggio 7 bulloni.

Kommutator komplett mit neuer Dichtung einsetzen. Die flache Seite der Dichtung zeigt nach außen.

Fit commutator assembly with new seals. Assemble seal flat side out.

Remonter l'ensemble commutateur avec un nouveau joint côté plat à l'extérieur.

Montare il distributore con la nuova guarnizione con il lato piano verso l'esterno.

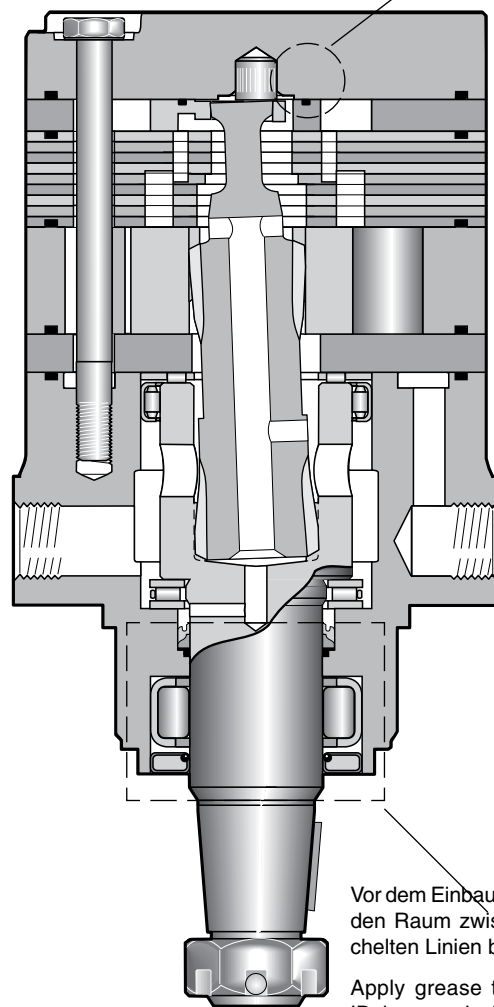
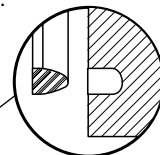



Vor dem Einbau der Abtriebswelle den Raum zwischen den gestrichelten Linien befeuchten.

Apply grease to shaft OD. and ID. in area designated by dotted lines.

Avant l'assemblage de l'arbre veuillez graisser l'espace situé entre les lignes en tirets.

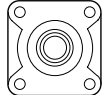
Prima del montaggio dell'albero pregasi lubrificare la zona evidenziata con linee tratteggiate.

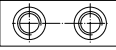
Pos. 1		
Gehäuse komplett Housing assembly Carter Scatola motore		
	MJ012007J4 CODE MW	-----
	MJ012002J4 CODE MS	MJ012001J4 CODE US
Endanschluss Rear port Orifices arrière Alim. laterale	MJ012004J4 CODE M*	MJ012003J4 CODE U*

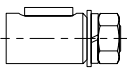
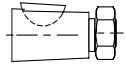
Pos. 2		Pos. 14	
Abtriebswelle / Coupling shaft Arbre / Albero uscita		Passfeder / Key Clavette / Chiavetta	
	Ø 1.5 inch MJ019001 CODE 32	039040	
	1:8 1.5 inch MJ019000 CODE 31	039046	

	Pos. 3		Pos. 4	Pos. 5
Baugröße Size Taille Grandezza	Schraube / Bolt / Bolt Vis / Vite	Für Endanschluss For rear port Pour orifices arrière Per alimentazione laterale	Rotor komplett Rotor set Jeu rotor Rotore	Zwischenwelle Drive link Abre d'entrain Albero entrata
140	021390	021273	ME097003	ME093000
170	021376	021387	ME107003	ME103000
195	021352	021379	ME127003	ME123000
240	021272	021291	ME157003	ME153000
280	021340	021392	ME187003	ME183000
335	021273	021385	ME217003	ME213000
405	021379	021415	ME247003	ME243000
475	021392	021394	ME297003	ME293000
530	021385	021393	ME337003	ME333000
625	021366	021329	ME377003	ME373000
785	021395	021388	ME487003	ME483000
960	021396	021389	ME587003	ME583000

Pos. 19	
Federring / Spring washer Rondelle grower Rondella elastica	G103327

Pos. 18	
Scheibe / Washer Rondelle / Rondella	401464

Pos. 17	
Schraube / Bolt Vis / Vite	G426477

Pos. 6	
Dichtsatz komplett Seal kit Jeu de joints Kit guarnizioni	SK000115

Pos. 8	
Axiallager Thrust bearing Roulement Cuscinetto reggispinta	068024

Pos. 9	
Zwischenscheibe Wear plate Plaque d'usure Piastra d'usura	477342

Pos. 10		
Verteiler Manifold Plan de pose Distributore	ME015000 Standard	CODE 0
Verteiler Manifold Plan de pose Distributore	ME015001 Reverse	CODE 1

Pos. 12	
Kommutator komplett Commutator assembly Ensemble commutateur Assieme distributore	ME018000A1
Für Endanschluss For rear port Pour orifices arrière Per alimentazione laterale	ME018001A1

Pos. 13		
Abschlussplatte / End cover Couvercle / Coperchio posteriore ME016000 Standard		
Für Endanschluss / For rear port Pour orifices arrière Per alimentazione laterale		
ME016009	7/8-14 UNF Axial	CODE A
ME016002	7/8-14 UNF Radial	CODE B
ME016007	Universal	CODE L
ME016010	G 1/2 Radial	CODE X
ME016011	G 1/2 Axial	CODE Y

Pos. 15	
Selbstsichernde Mutter Self-locking nut Ecrou nyl-stop Dado autobloccante	025131
Kronenmutter Castle nut Ecrou crénelé Tuerca	025133

Pos. 16	
Wellenring Circlip Circlips Anello seeger	401464

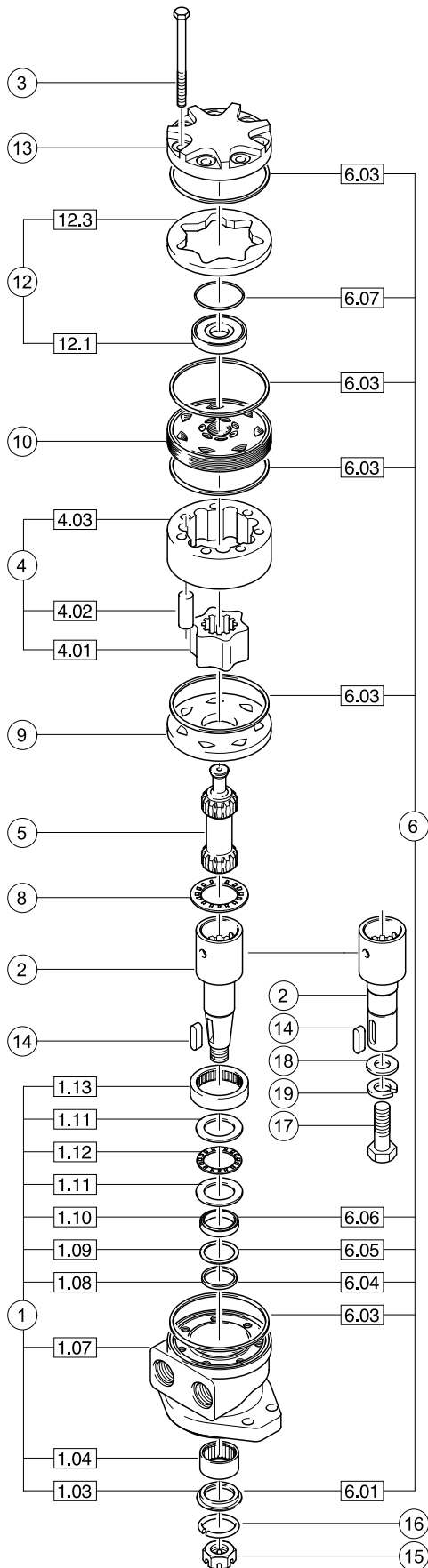

61...75Nm Anziehmoment wechselseitig an 7 Schrauben.

61...75Nm torque max. 7 bolts crosswise.

61...75Nm couple moteur max. 7 boulons réciproquement.

61...75Nm coppia di serraggio 7 bulloni.

Kommutator komplett mit neuer Dichtung einsetzen. Die flache Seite der Dichtung zeigt nach außen.

Fit commutator assembly with new seals. Assemble seal flat side out.

Remonter l'ensemble commutateur avec un nouveau joint côté plat à l'extérieur.

Montare il distributore con la nuova guarnizione con il lato piano verso l'esterno.

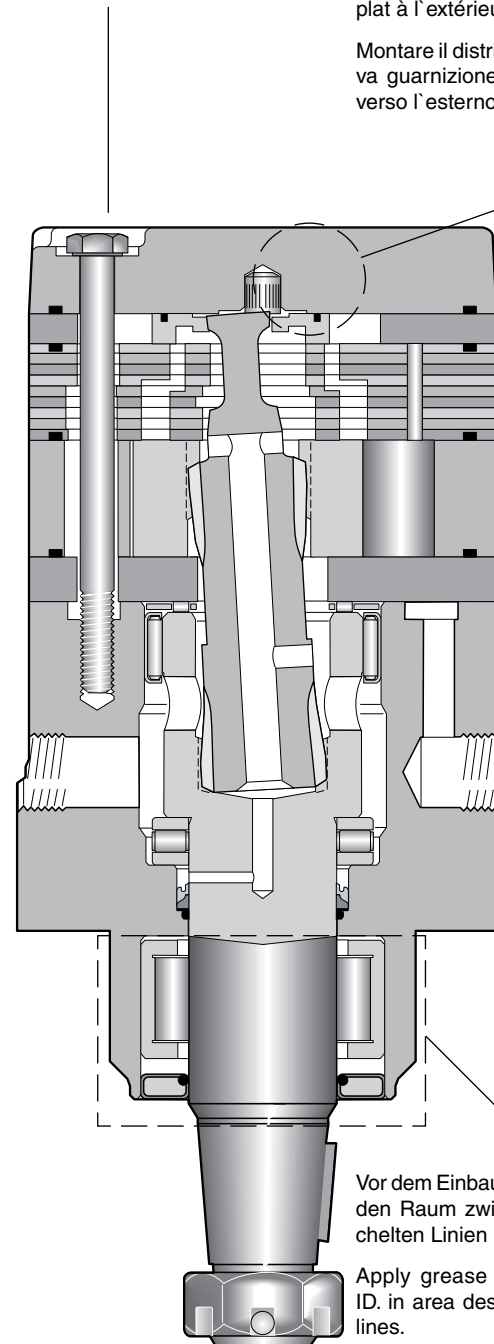

Vor dem Einbau der Abtriebswelle den Raum zwischen den gestrichelten Linien be fetten.

Apply grease to shaft OD. and ID. in area designated by dotted lines.

Avant l'assemblage de l'arbre veuillez graisser l'espace situé entre les lignes en tirets.

Prima del montaggio dell'albero pregasi lubrificare la zona evidenziata con linee tratteggiate.

Empfohlen wird die Verwendung eines Hydrauliköls auf Mineralölbasis mit mindestens 0,1% Zinkadditiv als Anti-verschleißzusatz. Vor Einsatz anderer Flüssigkeiten bitten wir um Rücksprache mit unserer Technik.

Die normale Arbeitstemperatur sollte im Bereich von +30 °C bis +60 °C liegen.

Die Maximaltemperatur darf +90 °C nicht überschreiten, während die Mindesttemperatur auf -30 °C begrenzt ist. Wird die normale Arbeitstemperatur wesentlich überschritten, wird die Lebensdauer des Öls stark verkürzt.

Die Viskosität im Arbeitstemperaturbereich sollte 20 bis 120 mm²/s betragen.

Zweckmäßig ist eine Filtereinheit von 20 bis 50 µm.

Die im Katalog angegebenen technischen Daten gelten für den Motorbetrieb.

Arbeitet der Motor als Pumpe, ist das auf die Antriebswelle wirkende Moment auf den angegebenen kontinuierlichen Maximalwert zu begrenzen. Dabei muss ein Vorspanndruck von 5 - 10 bar, abhängig vom Förderstrom, vorhanden sein (Kavitationsgefahr).

It is recommended to use a mineral based hydraulic oil with minimum 0.1% of zinc as anti-wear additive.

Before using other liquids, please consult our engineering department.

Normal working temperatures should be in the range of between +30 °C and +60 °C.

Maximum temperatures must not exceed +90 °C whilst minimum temperatures should be limited to -30 °C.

If normal working temperatures are substantially exceeded this will result in reduced life duration of the oil used.

Viscosity in the range of working temperatures should be 20 to 120mm²/s.

It is advisable to use a filtering fineness of 20 to 50 µm.

The technical data are applicable to motor operation. If the motor is used as a pump, the input torque on the coupling shaft must be limited to the indicated continuous maximum value. For this, an inlet pressure of 5 -10 bar must be applied depending on oil flow (danger of cavitation).

Il est recommandé d'utiliser une huile hydraulique à base minérale contenant au minimum 0,1% d'additif zinc comme produit anti-usure. Contactez-nous avant d'utiliser d'autres huiles.

La température normale d'utilisation devrait être située entre +30 °C à +60 °C.

La température maximale d'utilisation ne doit pas être supérieure à +90 °C, alors que la température minimale est limitée à -30 °C.

Lorsque la température de service est largement dépassée, la durée de vie de l'huile est fortement diminuée.

Dans la plage de température de service, la viscosité devrait être située entre 20 et 120 mm²/s.

Dans ce but, la filtration est de 20 à 50 µm.

Les caractéristiques techniques indiquées dans le catalogue sont considérées pour une utilisation en fonction moteur.

Si le moteur fonctionne en pompe, il faut limiter le couple à la valeur maximale indiquée. Dans ce cas, en fonction du débit, il faut créer une contre-pression de 5 à 10 bar (danger de cavitation).

Come elemento antiusura aggiuntivo si consiglia l'impiego di olio idraulico a base di olio minerale con almeno 0,1% di additivo allo zinco. Prima dell'impiego di altri liquidi si prega di contattare il nostro ufficio tecnico.

La temperatura normale di esercizio dovrebbe essere da +30 °C a +60 °C.

La temperatura massima non deve superare +90 °C, mentre la temperatura minima è limitata a -30° C.

Se la temperatura normale di esercizio viene sostanzialmente superata, la durata dell'olio diminuisce sensibilmente.

La viscosità nel campo della temperatura di esercizio dovrebbe essere da 20 a 120 mm²/s.

Si deve prevedere un sistema filtrante per 20...50 µm.

I dati suesposti sono validi negli impieghi come motore. Se il motore viene usato come pompa, la coppia sull'albero deve essere limitata a quella massima ammessa. Pertanto il motore deve essere pressurizzato da 5...10 bar in funzione della portata d'olio per evitare cavitazione.

Position notification regarding Machinery Directive 2006/42/EC:

Products made by the Pump & Motor Division Europe (PMDE) of Parker Hannifin are excluded from the scope of the machinery directive following the “Cetop” Position Paper on the implementation of the Machinery Directive 2006/42/EC in the Fluid Power Industry.

All PMDE products are designed and manufactured considering the basic as well as the proven safety principles according to:

- ISO 13849-1:2015
- SS-EN ISO 4413:2010

so that the machines in which the products are incorporated meet the essential health and safety requirements.

Confirmations for components to be proven component, e. g. for validation of hydraulic systems, can only be provided after an analysis of the specific application, as the fact to be a proven component mainly depends on the specific application.

Dr. Hans Haas

General Manger

Pump & Motor Division Europe

**ACHTUNG — VERANTWORTUNG DES ANWENDERS**

VERSAGEN ODER UNSACHGEMÄßE AUSWAHL ODER UNSACHGEMÄßE VERWENDUNG DER HIERIN BESCHRIEBENEN PRODUKTE ODER ZUGEHÖRIGER TEILE KÖNNEN TOD, VERLETZUNGEN VON PERSONEN ODER SACHSCHÄDEN VERURSACHEN.

Dieses Dokument und andere Informationen von der Parker-Hannifin Corporation, seinen Tochtergesellschaften und Vertragshändlern enthalten Produkt- oder Systemoptionen zur weiteren Untersuchung durch Anwender mit technischen Kenntnissen. Der Anwender ist durch eigene Untersuchung und Prüfung allein dafür verantwortlich, die endgültige Auswahl des Systems und der Komponenten zu treffen und sich zu vergewissern, dass alle Leistungs-, Dauerfestigkeits-, Wartungs-, Sicherheits- und Warnanforderungen der Anwendung erfüllt werden. Der Anwender muss alle Aspekte der Anwendung genau untersuchen, geltenden Industrienormen folgen und die Informationen in Bezug auf das Produkt im aktuellen Produktkatalog sowie alle anderen Unterlagen, die von Parker oder seinen Tochtergesellschaften oder Vertragshändlern bereitgestellt werden, zu beachten. Soweit Parker oder seine Tochtergesellschaften oder Vertragshändler Komponenten oder Systemoptionen basierend auf technischen Daten oder Spezifikationen liefern, die vom Anwender beigestellt wurden, ist der Anwender dafür verantwortlich festzustellen, dass diese technischen Daten und Spezifikationen für alle Anwendungen und vernünftigerweise vorhersehbaren Verwendungszwecke der Komponenten oder Systeme geeignet sind und ausreichen.

Verkaufs-Angebot

Wenden Sie sich bitte wegen eines ausführlichen Verkaufs-Angebotes an Ihre Parker-Vertretung.

**WARNING - USER RESPONSIBILITY**

FAILURE OR IMPROPER SELECTION OR IMPROPER USE OF THE PRODUCTS DESCRIBED HEREIN OR RELATED ITEMS CAN CAUSE DEATH, PERSONAL INJURY AND PROPERTY DAMAGE.

This document and other information from Parker-Hannifin Corporation, its subsidiaries and authorized distributors provide product or system options for further investigation by users having technical expertise.

The user, through its own analysis and testing, is solely responsible for making the final selection of the system and components and assuring that all performance, endurance, maintenance, safety and warning requirements of the application are met. The user must analyze all aspects of the application, follow applicable industry standards, and follow the information concerning the product in the current product catalog and in any other materials provided from Parker or its subsidiaries or authorized distributors.

To the extent that Parker or its subsidiaries or authorized distributors provide component or system options based upon data or specifications provided by the user, the user is responsible for determining that such data and specifications are suitable and sufficient for all applications and reasonably foreseeable uses of the components or systems.

Offer of Sale

Please contact your Parker representation for a detailed "Offer of Sale".

**AVERTISSEMENT — RESPONSABILITE DE L'UTILISATEUR**

LA DÉFECTUOSITÉ OU LA SÉLECTION OU L'USAGE ABUSIF DES PRODUITS DÉCRITS DANS LE PRÉSENT DOCUMENT OU D'ARTICLES ASSOCIÉS PEUT ENTRAÎNER LA MORT, DES BLESSURES ET DES DOMMAGES MATÉRIELS.

Ce document et d'autres informations de Parker-Hannifin Corporation, ses filiales et distributeurs autorisés, proposent des options de produit et de système destinées aux utilisateurs possédant de solides connaissances techniques.

En procédant à ses propres analyses et essais, l'utilisateur est seul responsable de la sélection définitive du système et des composants, au même titre qu'il lui incombe de veiller à la satisfaction des exigences en matière de performances, endurance, entretien, sécurité et avertissement. L'utilisateur doit analyser tous les aspects de l'application, suivre les normes applicables de l'industrie et les informations concernant le produit dans le catalogue de produits actuel et dans tout autre document fourni par Parker, ses filiales ou distributeurs agréés.

Dans la mesure où Parker ou ses filiales ou distributeurs agréés fournissent des options de système ou de composant se basant sur les données ou les spécifications indiquées par l'utilisateur, c'est à celui-ci qu'incombe la responsabilité de déterminer si ces données et spécifications conviennent et sont suffisantes pour toutes les applications et utilisations raisonnablement prévisibles des composants ou des systèmes.

Offre de vente

Veillez contacter votre représentant Parker pour obtenir une « Offre de vente » détaillée.

**AVVERTENZA - RESPONSABILITÀ DELL'UTENTE**

UN Malfunzionamento, una scelta inappropriata o l'uso improprio dei prodotti ivi descritti o dei componenti correlati possono causare decesso, lesioni personali e danni al patrimonio.

- Il presente documento e le altre informazioni divulgate da Parker Hannifin Corporation, dalle sue consociate e dai distributori autorizzati forniscono opzioni di prodotti o sistemi che devono essere ulteriormente analizzate da utenti con competenze tecniche.
- L'utente, attraverso processi di analisi e verifica, si assume la responsabilità assoluta per la scelta finale del sistema e dei componenti e per garantire che vengano soddisfatti tutti i requisiti dell'applicazione in merito a performance, resistenza, manutenzione, sicurezza e avvertenze. L'utente ha l'obbligo di analizzare tutti gli aspetti dell'applicazione, attenersi agli standard di settore applicabili e seguire le informazioni sul prodotto incluse nel catalogo dei prodotti corrente e in qualsiasi altro materiale fornito da Parker o dalle sue consociate o dai distributori autorizzati.
- Nella misura in cui Parker o le sue consociate o i distributori autorizzati forniscono opzioni di componenti o sistemi in base alle informazioni o alle specifiche indicate dall'utente, l'utente ha la responsabilità di verificare che tali informazioni e specifiche siano appropriate e sufficienti per tutte le applicazioni e gli usi ragionevolmente prevedibili dei componenti o dei sistemi.

Preventivo

Rivolgersi al proprio rappresentante Parker per un "Preventivo" dettagliato.



Parker Hannifin Manufacturing Germany GmbH & Co KG
Pump & Motor Division Europe
Neefestr. 96
09116 Chemnitz
Germany
Tel.: +49 (0)371 39370
www.parker.com/pmde

MSG30-3207/EU

© Copyright 2018
All rights reserved