

EPF *iprotect*[®] (Ecological Pressure Filter)

High Pressure Filters
Max 700 l/min - 450 bar



A compact, cost effective pressure filter solution

Designed with the *iprotect*[®] patented filtration technology

The Parker EPF *iprotect*[®] (Ecological High Pressure Filter) is designed to provide high quality filtration of hydraulic systems, providing new possibilities to reduce the cost of ownership by improving their productivity and profitability.

A radical, innovative approach was applied with the design of the EPF *iprotect*[®], suitable for a flow capacity up to 700 l/min at 450 bar working pressure.

A new patented design of the filter element allows integration of the bypass valve and element core as re-usable parts in the filter bowl. This makes the product fool proof as there is no risk of forgetting to re-install re-usable parts.

With less space being available for filters, Parker has taken on board the requirement to provide more compact solutions. A unique feature is the filter element remains inside the filter bowl when changing the filter element. This can save over 500mm of space envelope in comparison with traditional high pressure filters.



Product Features:

The patented element design guarantees the quality of filtration, which directly impacts the oil cleanliness level as the usage of pirate type after market filters with unknown quality of filter media is excluded. This in-build safety has a direct, positive impact on the productivity and profitability of equipment.

- Guaranteed quality of filtration
- More compact solutions are possible
- Filter element remains in filter bowl during filter service
- Reduce waste of 50%
- No risk of installation mistakes due to a 'foolproof' design
- Unique OEM branding opportunities
- Easy to integrate into hydraulic manifold solutions

Features	Advantages	Benefits
Patented filter element	Avoid use of non-genuine parts	Guaranteed quality of filtration
Filter element remains in filter bowl	Less space needed to change/service filter	More compact solutions are possible Reduce service time for filter over 40%
Environmentally-friendly design	Reduces environmental waste over 50%	Lower disposal cost
Service-friendly product design	No handling of loose re-usable parts	No risk of making mistakes during change of element
Bypass valve integral part of filter bowl	Easy to integrate in manifold systems	More compact and lower cost of manifold (only one cavity is needed)
	Lower pressure lost across filter	Saving energy, improving system efficiency
Wide range of differential pressure indicators	Continuous feedback of condition filter elements	Optimizing filter element life
		Contributes to scheduled maintenance

Typical Applications

- Mobile working hydraulics
- Mobile drive system
- Pilot line filtration
- Servo controls
- Reverse flow valve applications
- Industrial working hydraulics
- Control systems

The Parker EPF *iprotect*[®] series patented bypass valve technology

Bypass settings are available up to 7 bar or completely blocked in conjunction with patented, high strength filter elements. The principle is

based on differential pressure measurement across the filter element. During bypass only a part of the mainflow is flowing through the bypass valve.

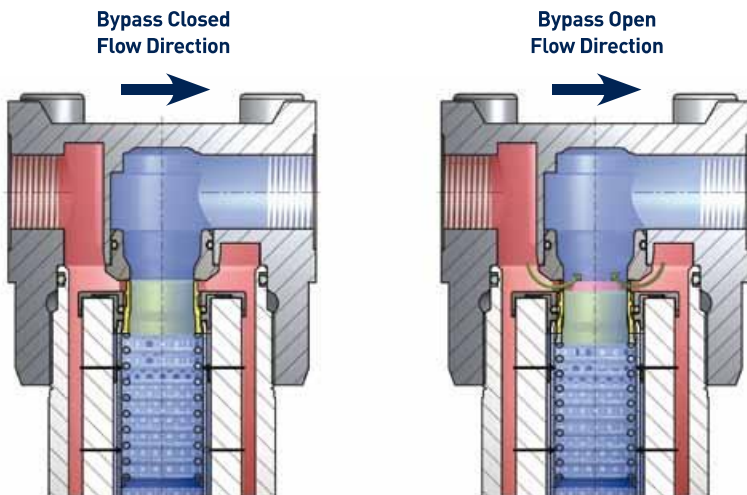

Epf *iprotect*[®] applies the latest generation of Microglass III filter media. The patented element design guarantees the quality of filtration.

EPF *iprotect*®

High Pressure Filters

Selecting the right EPF element

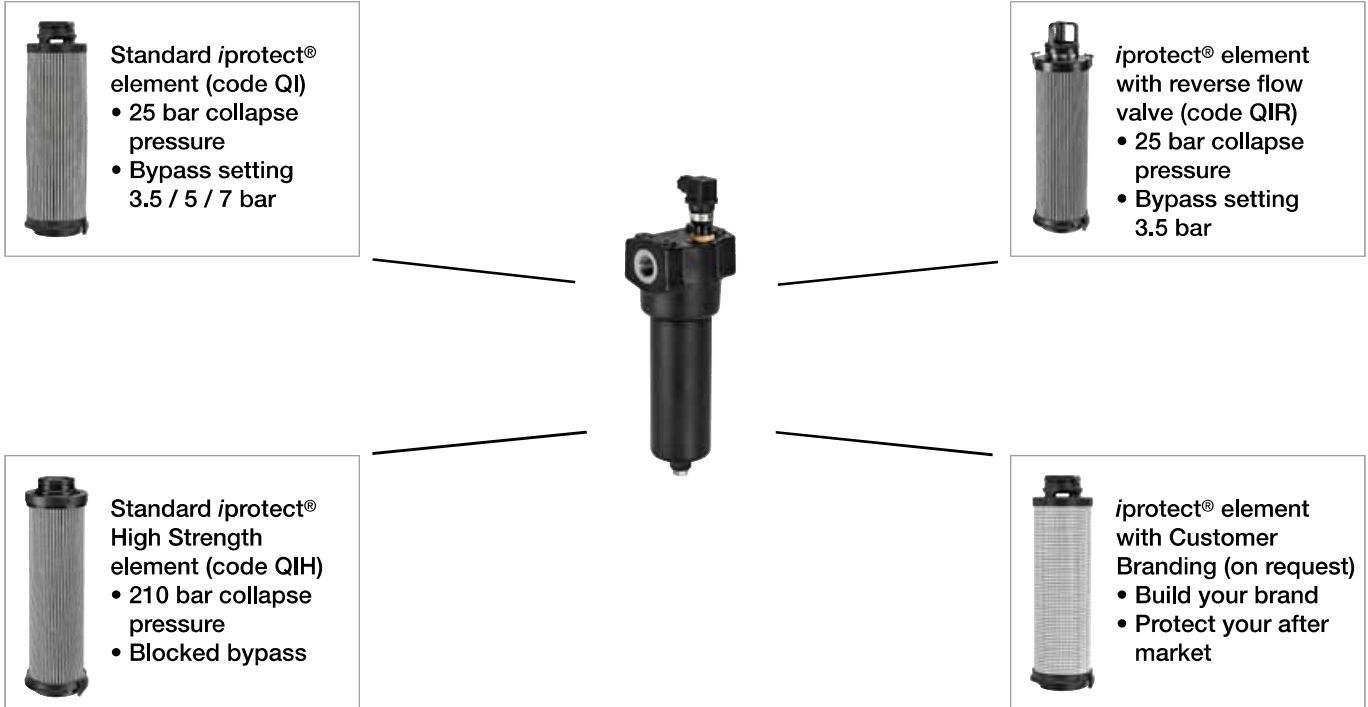

EPF Spare Element Information

Type QI

EPF Size1 L1 2 micron	944418Q
EPF Size1 L1 5 micron	944419Q
EPF Size1 L1 10 micron	944420Q
EPF Size1 L1 20 micron	944421Q
EPF Size 2 L1 2 micron	944426Q
EPF Size 2 L1 5 micron	944427Q
EPF Size 2 L1 10 micron	944428Q
EPF Size 2 L1 20 micron	944429Q
EPF Size 2 L2 2 micron	944430Q
EPF Size 2 L2 5 micron	944431Q
EPF Size 2 L2 10 micron	944432Q
EPF Size 2 L2 20 micron	944433Q
EPF Size 3 L1 2 micron	944434Q
EPF Size 3 L1 5 micron	944435Q
EPF Size 3 L1 10 micron	944436Q
EPF Size 3 L1 20 micron	944437Q
EPF Size 3 L2 2 micron	944438Q
EPF Size 3 L2 5 micron	944439Q
EPF Size 3 L2 10 micron	944440Q
EPF Size 3 L2 20 micron	944441Q
EPF Size 4 L1 2 micron	944442Q
EPF Size 4 L1 5 micron	944443Q
EPF Size 4 L1 10 micron	944444Q
EPF Size 4 L1 20 micron	944445Q
EPF Size 4 L2 2 micron	944446Q
EPF Size 4 L2 5 micron	944447Q
EPF Size 4 L2 10 micron	944448Q
EPF Size 4 L2 20 micron	944449Q
EPF Size 5 L1 2 micron	944450Q
EPF Size 5 L1 5 micron	944451Q
EPF Size 5 L1 10 micron	944452Q
EPF Size 5 L1 20 micron	944453Q

Type QIH

EPF High Strength Size1 L1 2 micron	944481Q
EPF High Strength Size1 L1 5 micron	944482Q
EPF High Strength Size1 L1 10 micron	944483Q
EPF High Strength Size1 L1 20 micron	944484Q
EPF High Strength Size 2 L1 2 micron	944489Q
EPF High Strength Size 2 L1 5 micron	944490Q
EPF High Strength Size 2 L1 10 micron	944491Q
EPF High Strength Size 2 L1 20 micron	944492Q
EPF High Strength Size 2 L2 2 micron	944493Q
EPF High Strength Size 2 L2 5 micron	944494Q
EPF High Strength Size 2 L2 10 micron	944495Q
EPF High Strength Size 2 L2 20 micron	944496Q
EPF High Strength Size 3 L1 2 micron	944497Q
EPF High Strength Size 3 L1 5 micron	944498Q
EPF High Strength Size 3 L1 10 micron	944499Q
EPF High Strength Size 3 L1 20 micron	944500Q
EPF High Strength Size 3 L2 2 micron	944501Q
EPF High Strength Size 3 L2 5 micron	944502Q
EPF High Strength Size 3 L2 10 micron	944503Q
EPF High Strength Size 3 L2 20 micron	944504Q
EPF High Strength Size 4 L1 2 micron	944505Q
EPF High Strength Size 4 L1 5 micron	944506Q
EPF High Strength Size 4 L1 10 micron	944507Q
EPF High Strength Size 4 L1 20 micron	944508Q
EPF High Strength Size 4 L2 2 micron	944509Q
EPF High Strength Size 4 L2 5 micron	944510Q
EPF High Strength Size 4 L2 10 micron	944511Q
EPF High Strength Size 4 L2 20 micron	944512Q
EPF High Strength Size 5 L1 2 micron	944513Q
EPF High Strength Size 5 L1 5 micron	944514Q
EPF High Strength Size 5 L1 10 micron	944515Q
EPF High Strength Size 5 L1 20 micron	944516Q

Type QIR

EPF Size1 L1 2 micron reverse flow	944561Q
EPF Size1 L1 5 micron reverse flow	944562Q
EPF Size1 L1 10 micron reverse flow	944563Q
EPF Size1 L1 20 micron reverse flow	944564Q
EPF Size 2 L1 2 micron reverse flow	944569Q
EPF Size 2 L1 5 micron reverse flow	944570Q
EPF Size 2 L1 10 micron reverse flow	944571Q
EPF Size 2 L1 20 micron reverse flow	944572Q
EPF Size 2 L2 2 micron reverse flow	944573Q
EPF Size 2 L2 5 micron reverse flow	944574Q
EPF Size 2 L2 10 micron reverse flow	944575Q
EPF Size 2 L2 20 micron reverse flow	944576Q
EPF Size 3 L1 2 micron reverse flow	944577Q
EPF Size 3 L1 5 micron reverse flow	944578Q
EPF Size 3 L1 10 micron reverse flow	944579Q
EPF Size 3 L1 20 micron reverse flow	944580Q
EPF Size 3 L2 2 micron reverse flow	944581Q
EPF Size 3 L2 5 micron reverse flow	944582Q
EPF Size 3 L2 10 micron reverse flow	944583Q
EPF Size 3 L2 20 micron reverse flow	944584Q
EPF Size 4 L1 2 micron reverse flow	944585Q
EPF Size 4 L1 5 micron reverse flow	944586Q
EPF Size 4 L1 10 micron reverse flow	944587Q
EPF Size 4 L1 20 micron reverse flow	944588Q
EPF Size 4 L2 2 micron reverse flow	944589Q
EPF Size 4 L2 5 micron reverse flow	944590Q
EPF Size 4 L2 10 micron reverse flow	944591Q
EPF Size 4 L2 20 micron reverse flow	944592Q
EPF Size 5 L1 2 micron reverse flow	944593Q
EPF Size 5 L1 5 micron reverse flow	944594Q
EPF Size 5 L1 10 micron reverse flow	944595Q
EPF Size 5 L1 20 micron reverse flow	944596Q

Protecting your system and the environment

Protect your system performance and profit

The new *iprotect*® generation of filter elements provide high filtration performance combined with Parker technology. The bespoke design prevents the use of pirate type alternatives.



Less space needed to accommodate the filter

More compact solutions are possible as the filter element remains in the filter bowl during change of filter element. Compared to traditional solutions it does not only save space, it also reduces the required manual handling during the filter change process.



Saving cost and our environment

What does it take to introduce a new ground-breaking design which saves the environment? Parker's EPF *iprotect*® applies a re-usable element core and bypass, both integral parts of the filter bowl. This solution avoids the handling of re-usable parts during element change and reduces over 50% disposal weight.



Smart valve technology

Parker hydraulic control valve technology is applied for the reusable bypass valve. This leakage-free valve has a patented interface with the filter element, which ensures that genuine parts are always applied. With bypass settings up to 7 bar filtration during cold start conditions, more compact solutions, can be realised. The valve also optimizes the flow path, reducing the pressure lost across the filter.



Easier to integrate

Parker has set the trend to integrate filtration into manifolds. With Parker's EPF *iprotect*® we have taken the design one step further. Only one cavity is needed to accommodate the filter instead of two, this is because the re-usable bypass valve is integrated into the filter bowl, reducing space and cost.



Customized solutions

Parker's motion & control technologies provide new opportunities for our customers. Customized manifolds or duplex filters, as in this example offer complete automatic change-over. The EPF *iprotect*® contributes to realizing new solutions, improving your productivity and profitability.



A protective 'gene'

The performance and profitability of systems directly depends upon the filter media.



It goes without saying that Parker's products aim to avoid the use of unknown filter performance, jeopardizing safety and performance. Our Microglass III media is continuously upgraded and acts as a protective 'gene' in the system.

When going into reverse

Parker's EPF can be equipped with an optional reverse flow. This valve assembly is integrated in the element end cap and isolates the filter medium during reverse flow conditions.



A new design of the filter element allows integration of the bypass valve and element core as re-usable parts in the filter bowl. This results in cost reduction when integrating the high pressure filter in manifold type solutions. But it also reduces the waste when changing the filter element by over 50% as the element core is an integral part of the filter bowl.

The design of the EPF *iprotect*®, is unique, there is no need to re-install any re-usable parts as with some other filters in the market. This makes the product fool proof as there is no risk of forgetting to re-install re-usable parts.



Replacing the filter element:

- Drain the filter housing using the plugged drain port.
- Thanks to the filter lock the element remains in the bowl.
- Pull out the old element. The re-usable element core and bypass valve are integral parts of the bowl.
- Filtration is from 'Out to In,' the element core is located in the clean oil side.
- Just drop the new element in the bowl.
- Screw the bowl, including element into the filter head.

EPF *iprotect*®

Size 3

Specification EPF *iprotect*® Size 3

Specification

Nominal flow >160 l/min

Pressure ratings

Maximum allowable operating pressure 450 bar

Filter housing pressure pulse fatigue tested

10⁶ pulses 0-414 bar

Connections

Inlet and outlet connections are threaded internally

Connection style

Thread G1

Thread SAE 16

Thread M33, ISO 6149

SAE flange 1 = 6000M

SAE flange 1 = 6000

Filter housing

Head material cast iron (GSI)

Bowl material steel

Seal material

Nitrile of Fluorelastomer

Operating temperature range

Seal material Nitrile : -40 °C to +100 °C

Seal material Fluorelastomer : -20 °C to +120 °C

Bypass valve & Indicator settings

Bypass Indicator

3.5 bar 2.5 bar

5.0 bar 3.5 bar

7.0 bar 5.0 bar

Blocked 5.0 bar

Filter element

Degree of filtration

Determined by multipass test in accordance to ISO16889

Flow fatigue characteristics

Filter media is supported so that the optimal fatigue life is achieved (ISO 3724)

Microglass III

Supported with epoxy coated metal wire mesh, end cap material reinforced composite and reusable metal inner core. Collapse pressure 25 bar (ISO 2941)

High collapse elements

To be used when bypass blocked option is selected

Collapse pressure 210 bar (ISO 2941)

Indicator options

Indicating differential pressure:

2.5 +/- 0.3 bar

3.5 +/- 0.3 bar

5.0 +/- 0.3 bar

Visual M3

Electrical T1

Electronic F1 (PNP)

Electronic F2 (NPN)

Atex versions are available on request

Weights (kg)

EPF Size 3 length 1: 6,7

EPF Size 3 length 2: 9,2

Fluid compatibility

- Hydraulic mineral oils H to class HLPD (DIN51524)
- Operating fluids DIN ISO 2943
- Lubrication fluids ISO6743, APJ, DIN 51517, ACEA, ASTM
- Vegetable oils
- 60/40 Water Glycols
- On request - Industrial grade phosphate esters
- Non aggressive synthetic oils
- Non aggressive bio-degradable oils (HETG, HEPG and HEES to VDMA 24568)

EPF *iprotect*® - Size 3 (Inline)

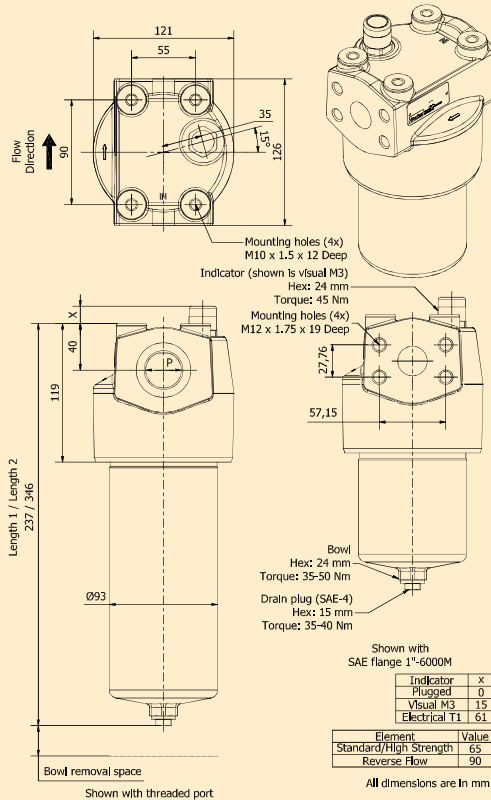

EPF *i*protect® Size 3 Pressure Drop Curves

With 3.5 bar bypass the recommended initial pressure drop max is 1.2 bar

With 7.0 bar bypass the recommended initial pressure drop max is 2.3 bar

If the medium used has a viscosity different from 30cSt, pressure drop over the filter can be estimated as follows:

The total $\Delta p = \text{housing } \Delta p_h + (\text{element } \Delta p_e \times \text{working viscosity}/30)$.

EPF Size 3 Empty Housing

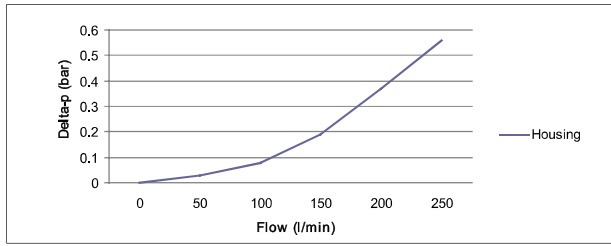

EPF Size 3 Length 1 Filter Elements

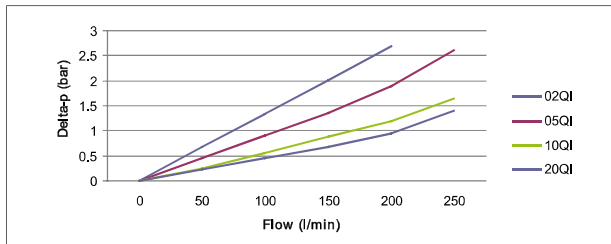

EPF Size 3 Length 2 Filter Elements

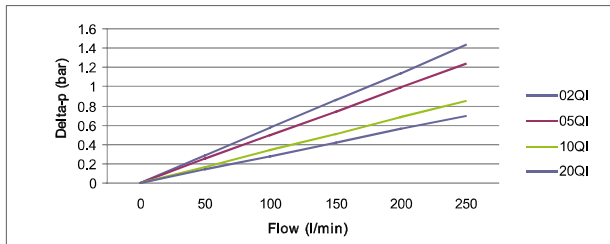

EPF Size 3 Length 1 Filter Elements with reverse flow valve

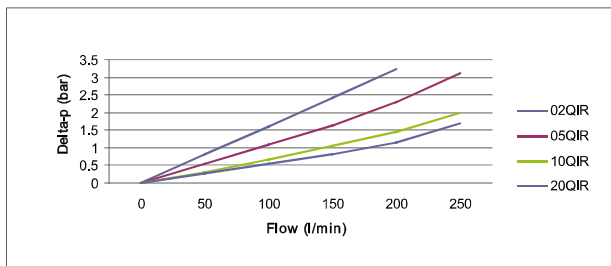

EPF Size 3 Length 2 Filter Elements with reverse flow valve

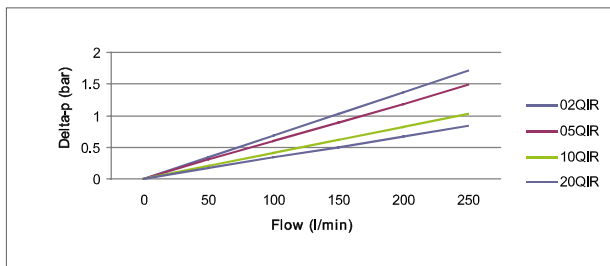

EPF Size 3 Length 1 High Strength Filter Elements

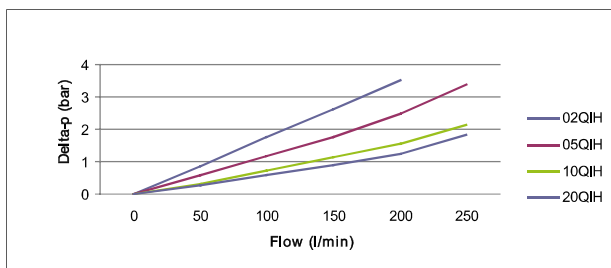

EPF Size 3 Length 2 High Strength Filter Elements

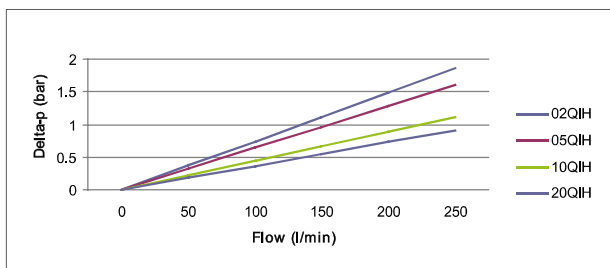

EPF *iprotect*[®]

High Pressure Filter

EPF3 1 10QI B M3 M G16 1

Ordering Information

Box 1	Box 2	Box 3	Box 4	Box 5	Box 6	Box 7	Box 8
EPF3	2	02QI	B	P	M	G16	1

Box 1

Capacity	
Model	Code
Size 1 (40 l/min)	EPF1
Size 2 (replaces 18P)	EPF2
Size 3 (replaces 28P)	EPF3
Size 4 (replaces 38P)	EPF4
Size 5	EPF5

Box 2

Filter Length	
	Code
Length 1	1
Length 2 (not for Size 1 and Size 5)	2

Highlights Key

(Denotes part number availability)

123	Item is standard
123	Item is standard green option
123	Item is semi standard
123	Item is non standard

Box 3

Degree of filtration				
	Media code			
<i>iprotect</i> [®] Glassfibre element	02QI	05QI	10QI	20QI
<i>iprotect</i> [®] with reverse flow valve(*)	02QIR	05QIR	10QIR	20QIR
<i>iprotect</i> [®] High Strength element	02QIH	05QIH	10QIH	20QIH

(*Note: Only in combination with 3.5 bar bypass)

Box 4

Seal Material	
	Code
Nitrile	B
Fluorelastomer	V

Box 5

Indicator	
	Code
Visual Indicator	M3
Electrical Indicator	T1
Electronic 4 LED, PNP, NO	F1
Electronic 4 LED, NPN, NO	F2
Electronic 4 LED, PNP, NC	F3
Electronic 4 LED, NPN, NC	F4
Plugged with Steel plug	P
No indicator port	N

Other versions like ATEX on request
All electrical indicators are CE-certified

Box 6

Bypass Setting		
	Indicator Setting	Code
3,5 bar	2,5 bar	K
5,0 bar	3,5 bar	L
7,0 bar	5,0 bar	M
No bypass	5,0 bar	M
No bypass	No indicator	X

Important notes: When no bypass is selected Parker strongly advises the use of high strength elements

Box 8

Options		
		Code
Standard		1
No bypass		2
Reverse flow valve	Safeguard valve only in combination with 3.5 bar bypass	RFV
ATEX certified* (Category 2, non-electrical equipment)		EX

Note 1: For non-bypass please select High strength element type QIH
Note 2: For ATEX classified filters add EX after the code. ATEX certified filters with electrical indicator are available on request. Visual indicators are classified as Category 2, non electrical equipment. Filter assemblies with EX code will be supplied with a dedicated name plate.
Pls consult Parker Filtration for any questions related to the classification of our products.

Box 7

Filter Connection		
	Connection type & size	Code
Size 1	Thread G½	G08
	Thread SAE 8	S08
Size 2	Thread G½	G08
	Thread G¾	G12
	Thread SAE 12	S12
	Thread M27, ISO 6149	M27
	SAE flange ¾ - 6000M	H12
	SAE flange ¾ - 6000	F12
	Manifold	X12
Size 3	Thread G1	G16
	Thread SAE 16	S16
	Thread M33, ISO 6149	M33
	SAE flange 1 - 6000M	H16
	SAE flange 1 - 6000	F16
Size 4	Thread G1¼	G20
	Thread G1½	G24
	Thread SAE20	S20
	Thread SAE24	S24
	Thread M42, ISO 6149	M42
	SAE flange 1¼ - 6000M	H20
	SAE flange 1¼ - 6000	F20
	Manifold	X20
Size 5	Thread G1½	G24
	Thread SAE 24	S24
	SAE flange 1½ - 6000M	H24
	Manifold	X20