

**Features****Torqmotor  
Series TF**

- **Langsamlaufender Gerotor-Motor**
  - **Spezielle Orbital-Steuerung**  
Geringe interne Leckage  
Hoher volumetrischer Wirkungsgrad
  - **Rollen im Rotorsatz**  
Reduzierte Reibung  
Lange Lebensdauer
  - **Patentierte Hochdruckwellendichtung**  
Keine Leckölleitung  
Keine Rückschlagventile
  - **Vielzahl von Varianten**  
Großer Einsatzbereich
- **Low Speed Gerotor Motor**
  - **Zero leak commutation valve**  
For greater, more consistent volumetric efficiency
  - **Roller vane rotor set**  
Reduces friction and internal leakage  
Maintaining efficiency throughout the life of the motor
  - **A patented high-pressure shaft seal**  
No check valves needed  
No extra plumbing
  - **Wide choice of displacement range, flange and shaft options**  
Greater efficiency in systems design to suit your application
- **Moteur lent système Gerotor**
  - **Une distribution orbitale particulière assure**  
fuites internes minimales  
rendements volumétriques élevés
  - **Le rotor à rouleaux**  
réduit les frottements  
augmente la durée de vie
  - **Par l'utilisation de joints d'arbre haute pression brevetés**  
pas de conduite de drainage  
pas de clapets anti-retour
  - **Grâce à de nombreuses variantes**  
larges domaines d'application
- **Motore orbitale a bassa velocità**
  - **Una particolare distribuzione orbitale assicura**  
trafilamento ridotto  
elevato rendimento volumetrico
  - **Con lo statore a rullini**  
si riduce l'attrito interno  
si mantiene nel tempo l'efficienza del motore
  - **Una guarnizione di tenuta ad alta pressione brevettata elimina la necessità**  
di una linea di drenaggio esterna  
e di valvole di non ritorno
  - **Un'ampia gamma di cilindrata, flange ed alberi**  
consentono scelte adeguate ad ogni esigenza costruttiva

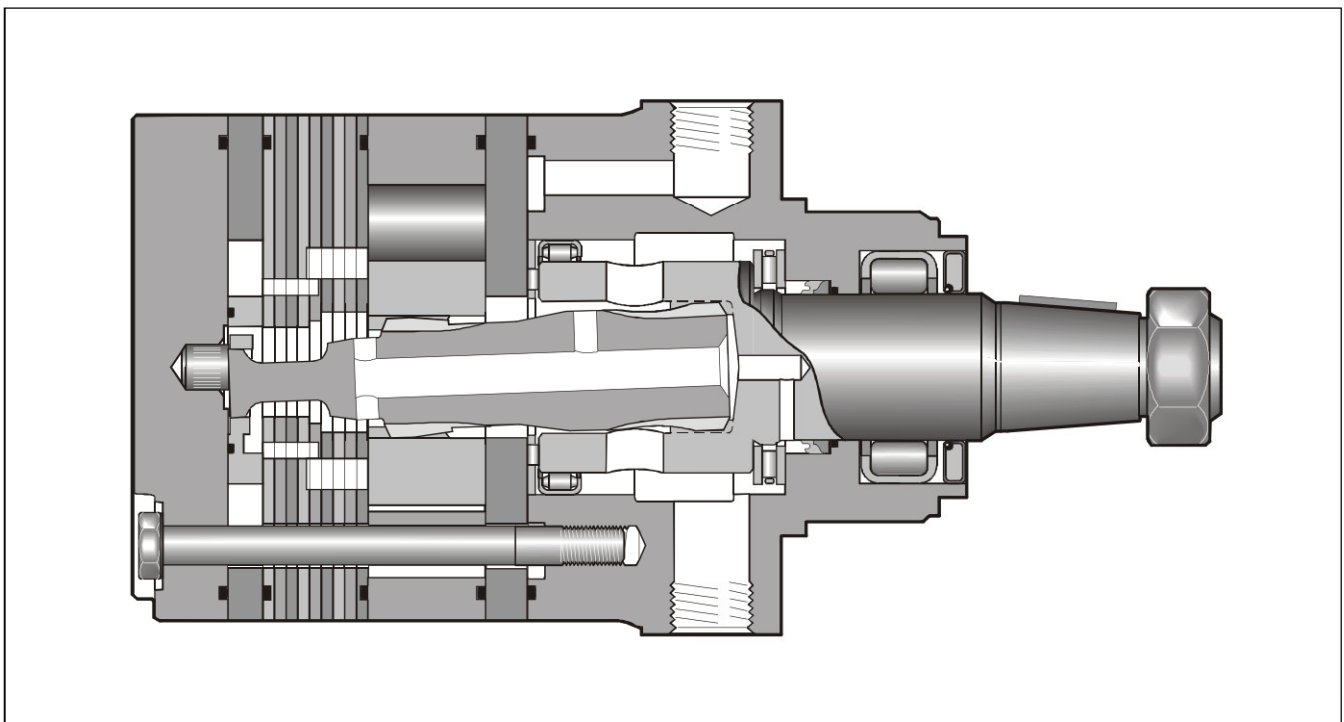

Torqmotoren 3213.PM6.5 RH

**Performance**

**Torqmotor  
Series TF**

Drehzahl Speed Vitesse de rotation Velocità di rotazione	5...750 rev/min
Schluckstrom Oil flow Débit d'huile Portata	max. 100 l/min
Eingangsdruck Supply pressure Pression entrée Pressione in entrata	max. 300 bar
Drehmoment Torque Couple Coppia	max. 900 Nm
Seitenlast Side load Charges latérales Carico radiale	max. 16.000 N

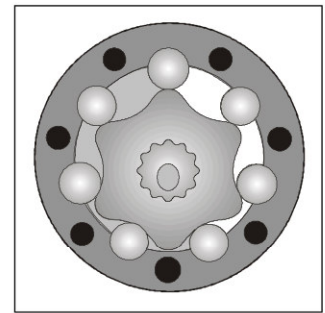
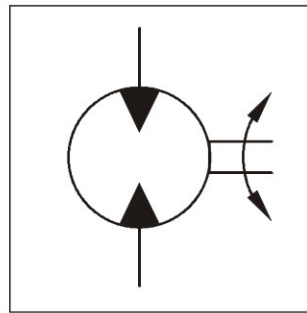

Motor series TF	cm <sup>3</sup> /U cm <sup>3</sup> /rev cm <sup>3</sup> /tr cm <sup>3</sup> /giro	cont / int U/min rev/min tr/min giri/min	cont / int l/min	cont / int bar	max bar	cont / int Nm	cont / int max. KW	cont / int Nm
TF 80	81	550/730	45/60	200/280	300	215/295	19	172/236
TF 100	100	600/750	60/75	160/240	300	210/315	21	168/252
TF 130	128	470/580	60/75	140/200	300	240/350	19	192/280
TF 140	141	370/530	60/75	140/200	300	250/390	18	197/308
TF 170	169	355/440	60/75	140/200	300	330/485	19	264/388
TF 195	197	300/380	60/75	140/200	300	380/560	19	304/448
TF 240	238	320/420	75/100	140/200	300	460/685	24	368/548
<b>TF 280</b>	280	270/350	75/100	140/200	300	550/800	24	440/640
TF 360	364	200/260	75/100	130/200	300	590/910	24	510/780
TF 405	405	170/230	75/100	130/175	300	650/910	21	575/789
TF 475	477	150/200	75/100	115/140	300	680/850	17	603/740

int. =  
 Intermittierende Werte maximal: 10% von jeder Betriebsminute.  
 Intermittent operation rating applies to 10% of every minute.  
 Fonctionnement interm.: 10% max. de chaque minute d'utilisation.  
 Servizio intermittente: 10% max di ogni minuto di utilizzazione.

Torqmotoren 3213.PM6.5 RH



**Code E**

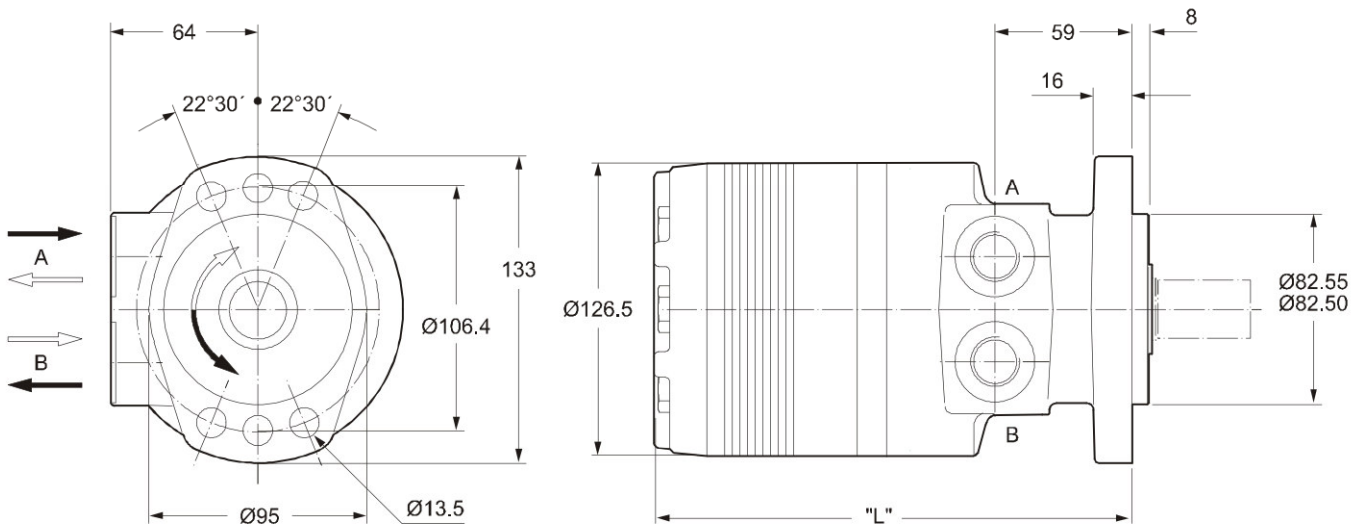

**Code M**

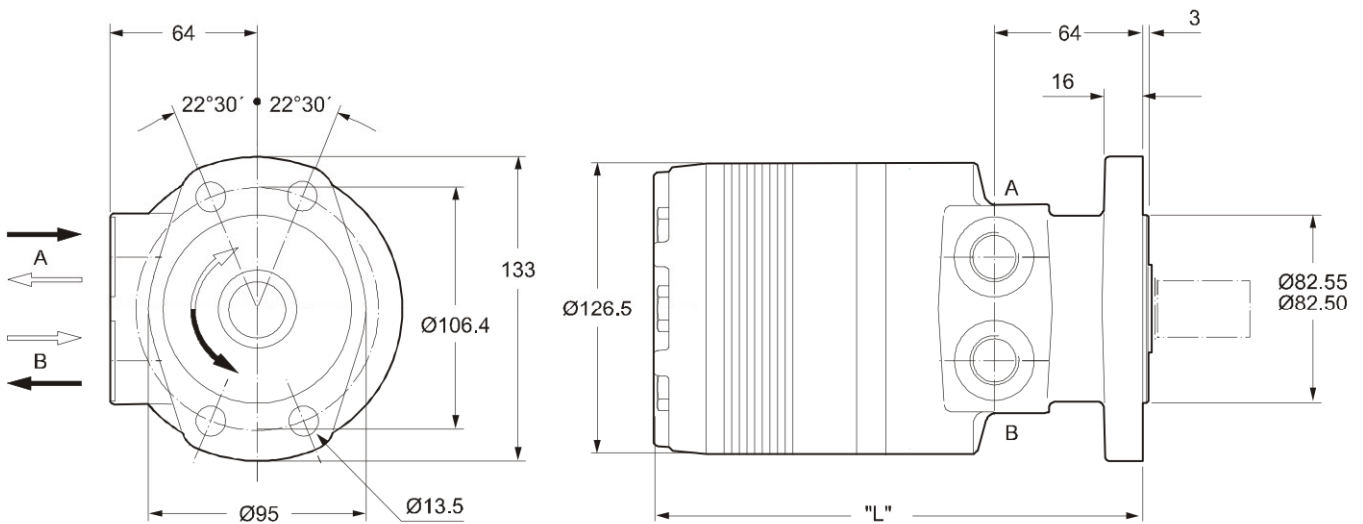

Gewicht / Weight		TF80	TF100	TF130	TF140	TF170	TF195	TF240	TF280	TF360	TF405	TF475
Poids / Peso	kg	13.6	13.7	13.9	14.0	14.2	14.7	15.0	15.5	16.0	16.5	17.5
Code E	"L" mm	186	186	189	191	194	197	202	206	215	220	229
Code M	"L" mm	191	191	194	196	199	202	207	212	220	225	234

**Code H**

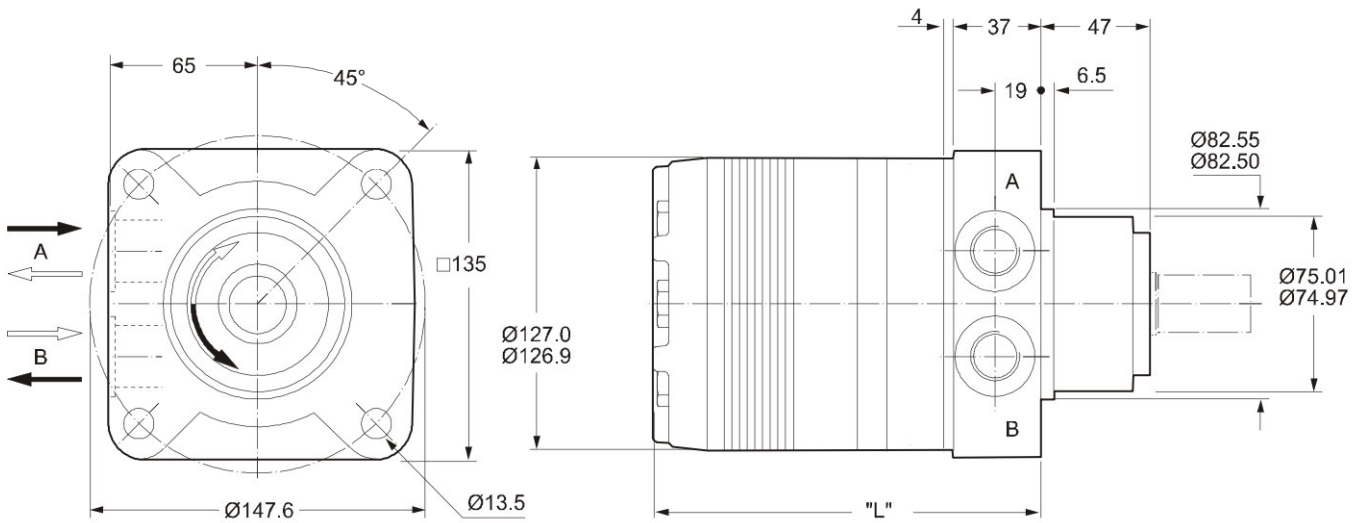

**Code V**

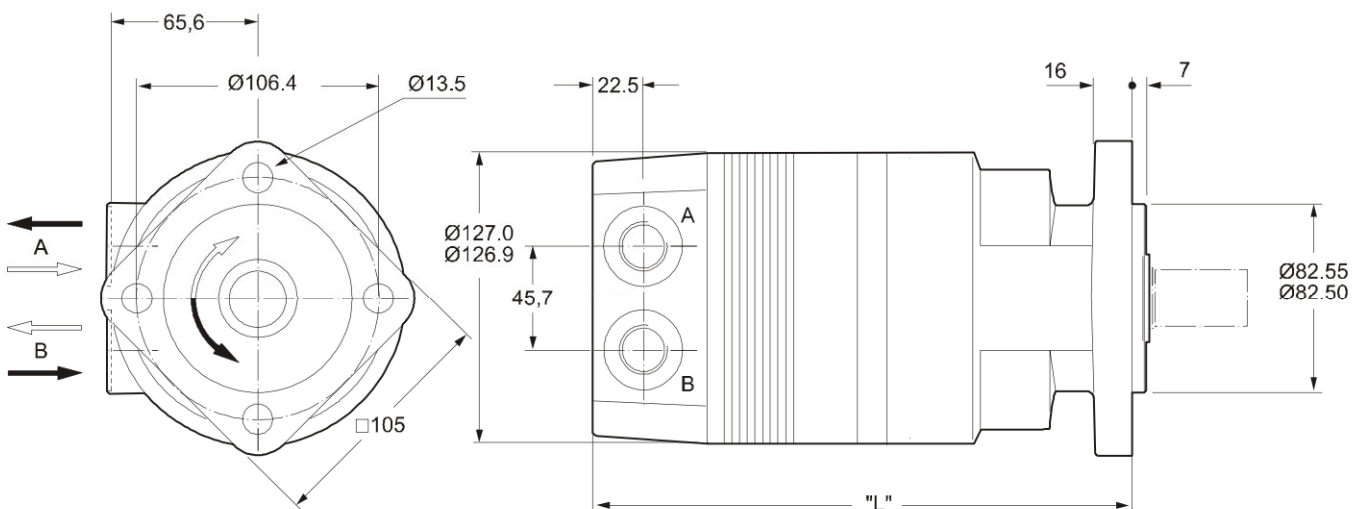

Gewicht / Weight		TF80	TF100	TF130	TF140	TF170	TF195	TF240	TF280	TF360	TF405	TF475
Poids / Peso	kg	14.0	14.0	14.2	14.3	14.6	14.9	15.3	15.6	16.3	17.0	17.5
Code H	"L" mm	146	146	149	151	154	157	162	167	175	180	189
Code V	"L" mm	213	213	216	218	221	224	229	233	242	247	256

**Code W**

G1/2 x 15

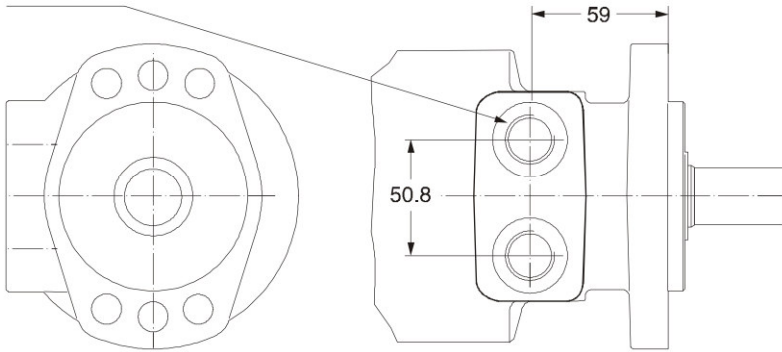

**Code N**

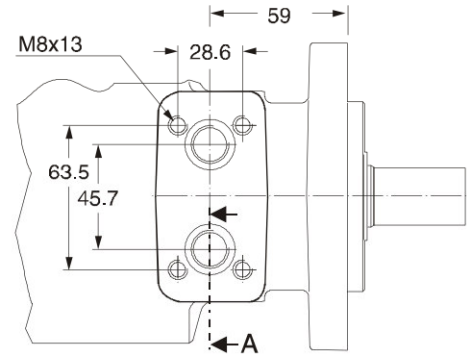

**Code W**

G1/2 x 15

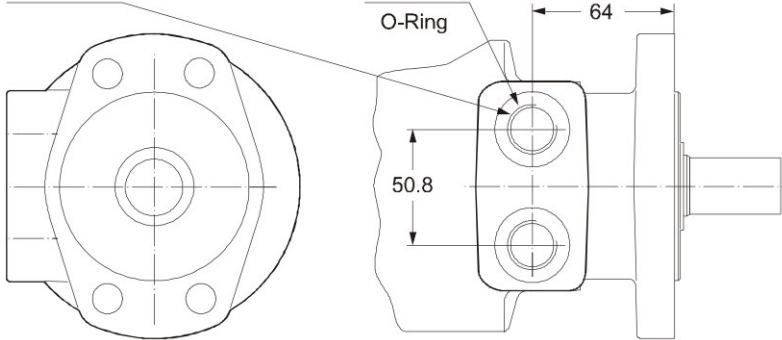

**Code V**

7/8-14UNF,  
O-Ring

**Code N**

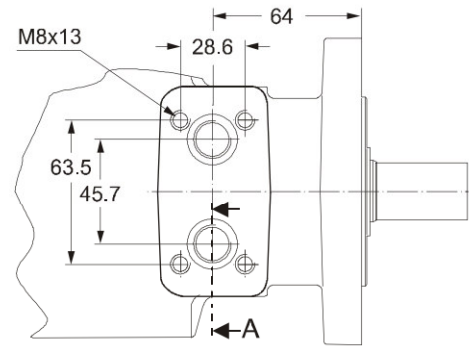

**Code W**

G1/2 x 15

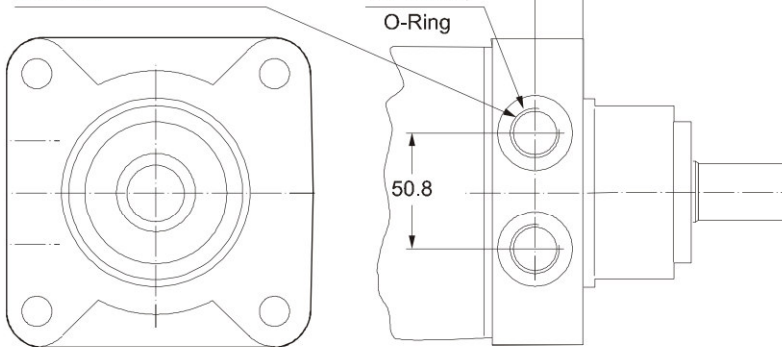

**Code V**

7/8-14UNF,  
O-Ring

**Code K**

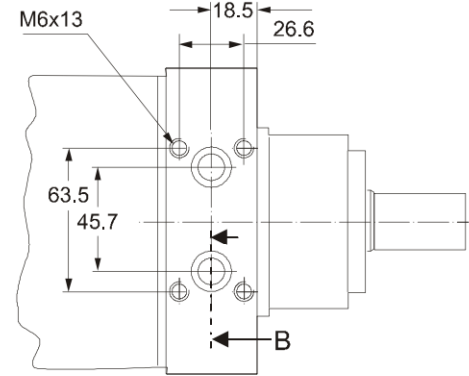

**Section A**

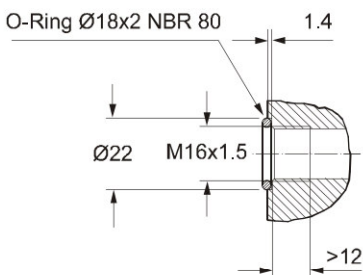

**Section B**

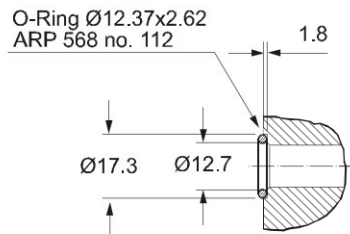

Zum Motor mit Universalanschluß werden 2 O-Ringe geliefert.

Motor with manifold mount is supplied with 2 O-rings.

Deux joints toriques sont livrés avec les moteurs au plan de raccordement universel.

Il blocchetto connessioni è corredato da 2 OR.

**Code B 7/8-14UNF**

**Code X G 1/2**

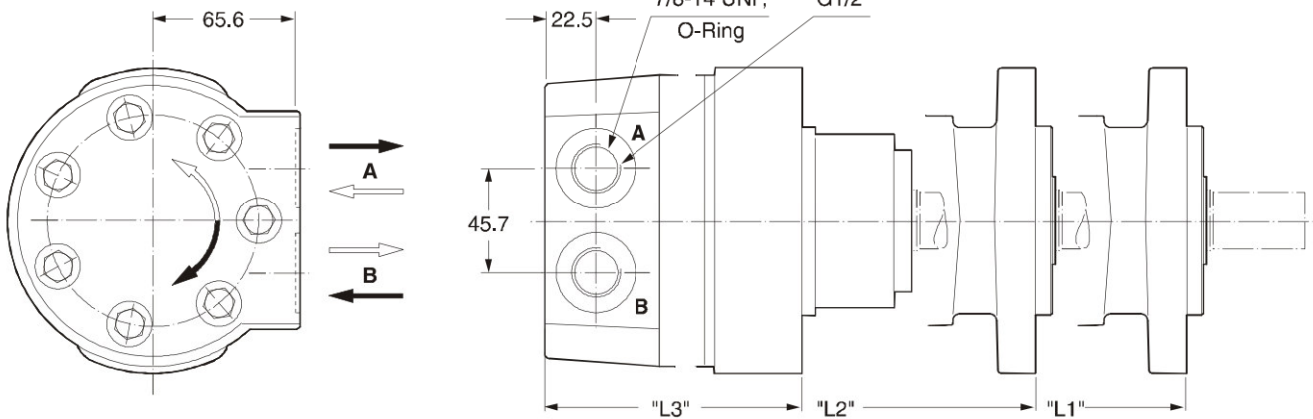

**Code L**

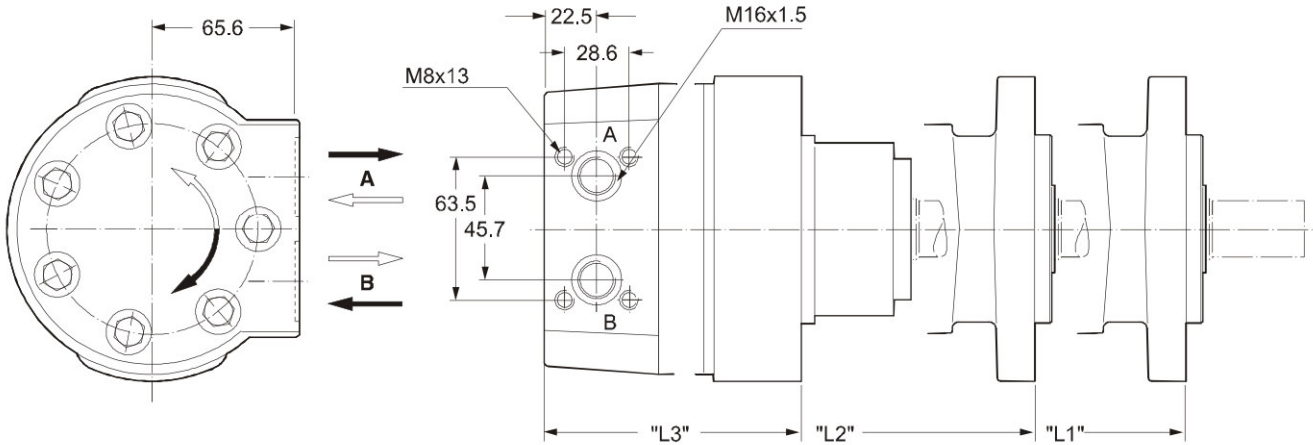

**Code A 7/8-14UNF**

**Code Y G 1/2**

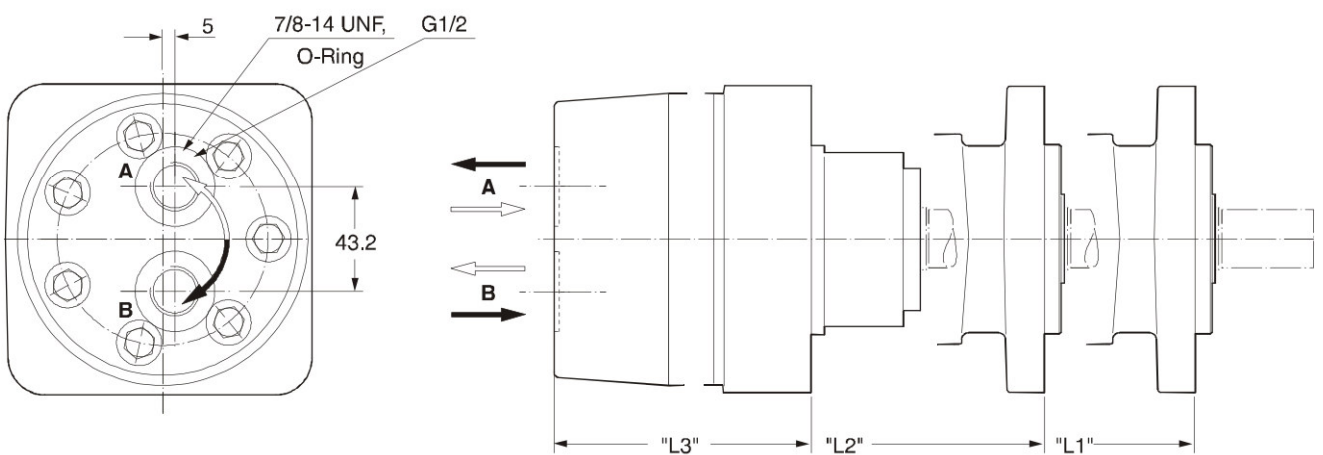

Gewicht / Weight		TF80	TF100	TF130	TF140	TF170	TF195	TF240	TF280	TF360	TF405	TF475
Poids / Peso	kg	15.3	15.4	15.6	15.7	16.0	16.3	16.7	17.0	17.8	18.3	19.0
Code	"L1" mm	211	211	214	216	219	222	227	231	240	245	254
B, X, L,	"L2" mm	216	216	219	221	224	227	232	236	246	250	259
A, Y	"L3" mm	170.2	170.2	173.3	175.1	178.1	181.4	186.0	190.8	200.5	204.5	213.2

Torqmotoren 3213.PM6.5 RH



**Code 44**

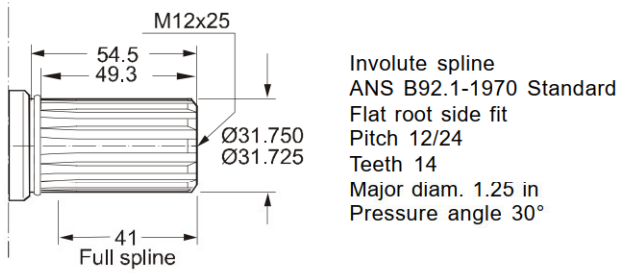

**Code 45**

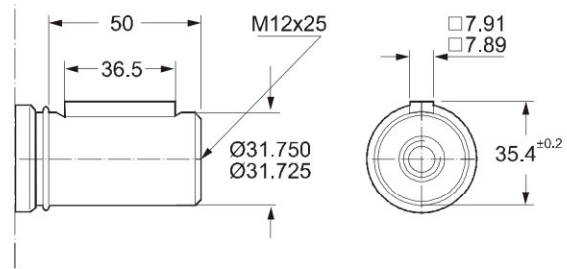

**Code 08**

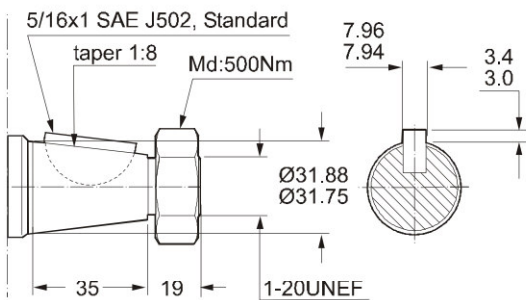

**Code 46**

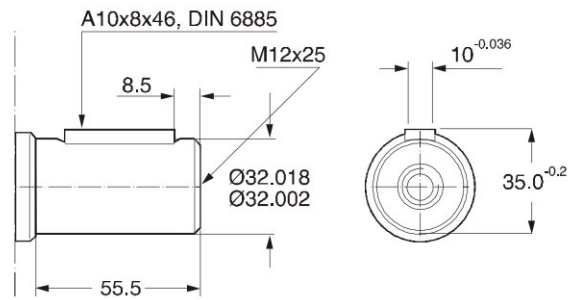

**Code 26**

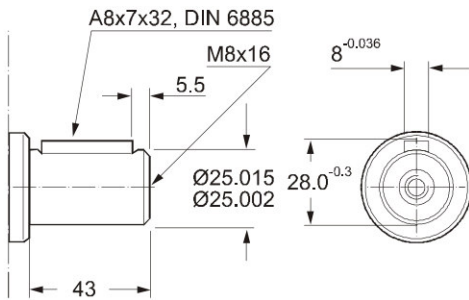

**Code 47**

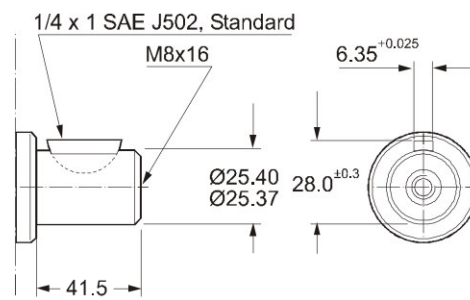

**Code 41**

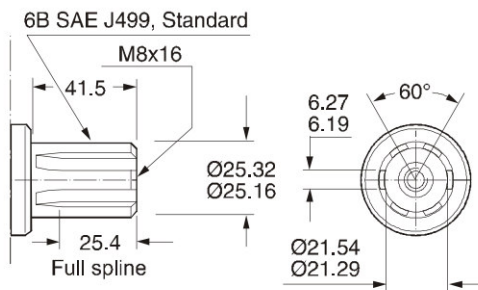

**Codes 26, 41, 47**

Abtriebswelle	Ø 25mm	Max. Moment cont./int.	} 450/550 Nm
Coupling shaft	Ø 1 inch	Max. torque cont./int.	
Arbre	6B SAE	Couple maxi cont./int.	
Albero		Coppia max cont./int.	

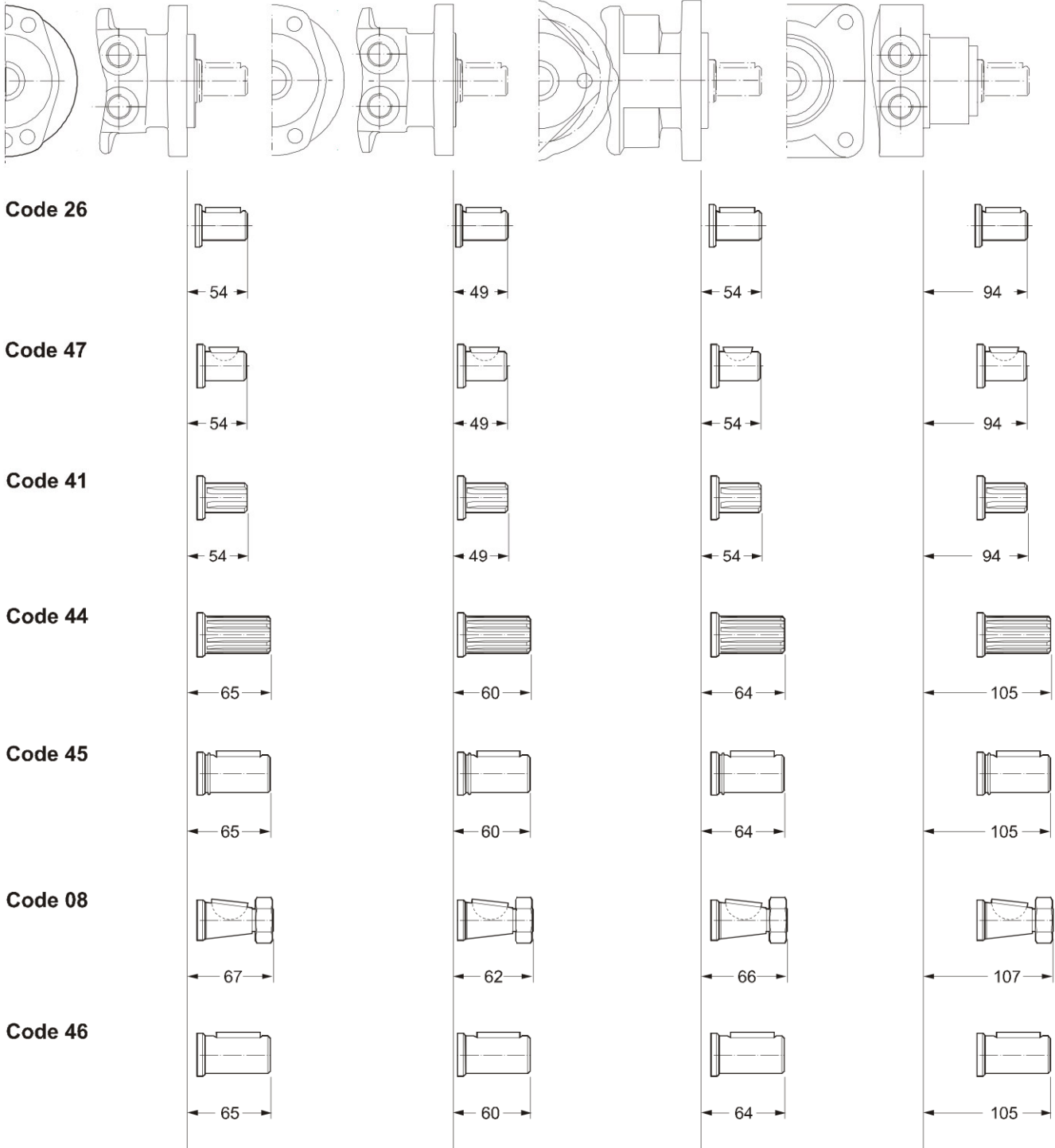



**Diagrams**

**Torqmotor  
Series TF**

**TF 80**

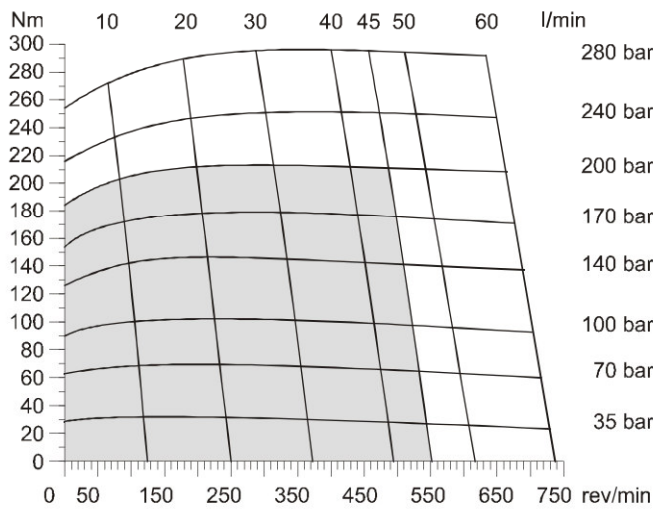

**TF 100**

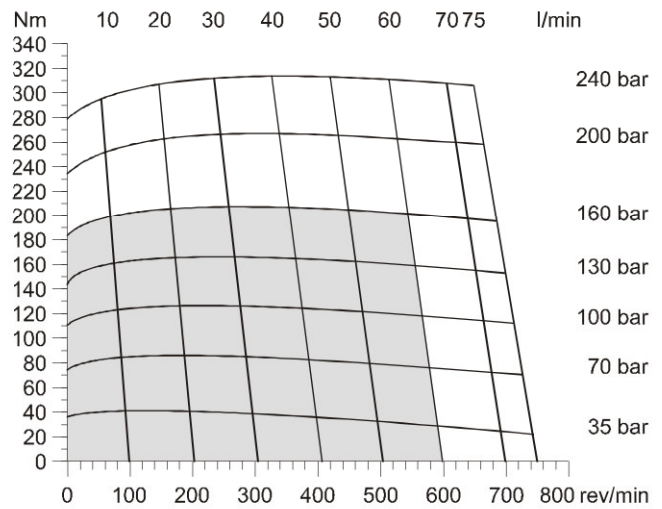

**TF 130**

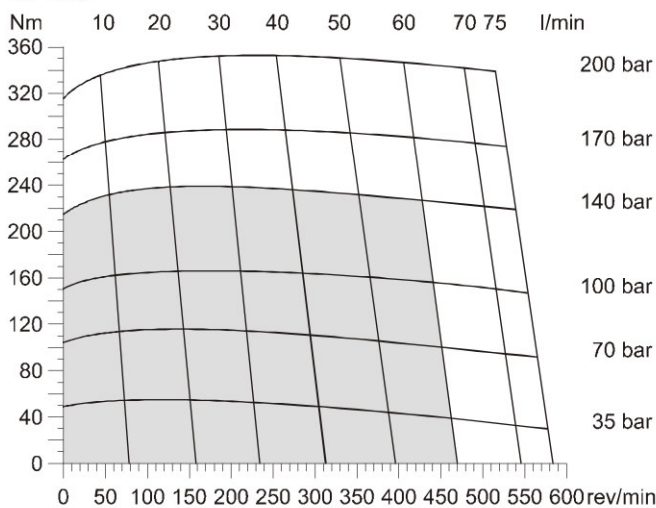

**TF 140**

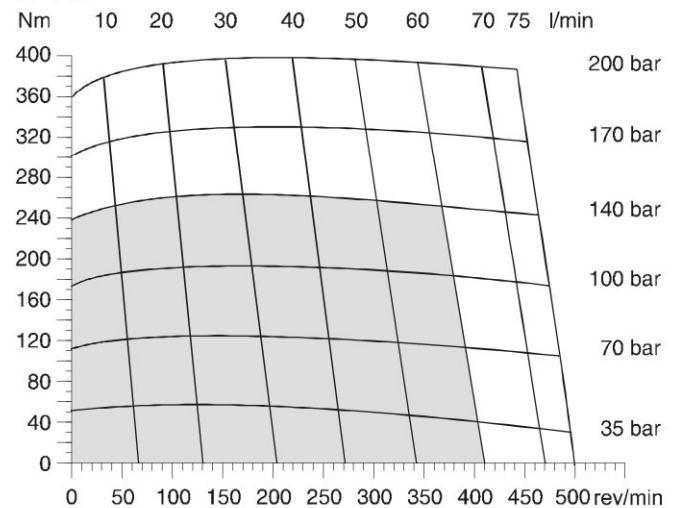

**TF 170**

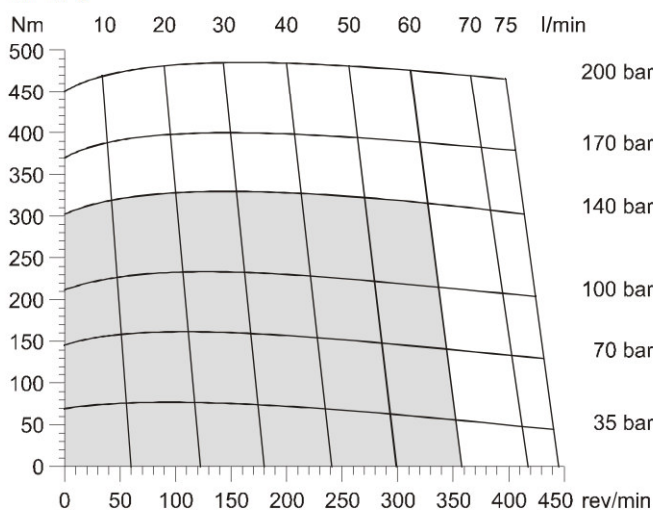

**TF 195**

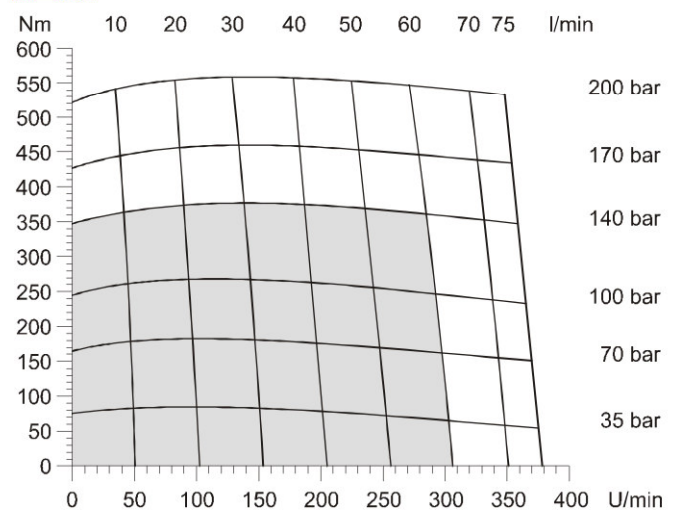

□ Cont.    □ Int.

int. =  
Intermittierende Werte maximal: 10% von jeder Betriebsminute.  
Intermittent operation rating applies to 10% of every minute.  
Fonctionnement interm.: 10% max. de chaque minute d'utilisation.  
Servizio intermittente: 10% max di ogni minuto di utilizzazione.

**TF 240**

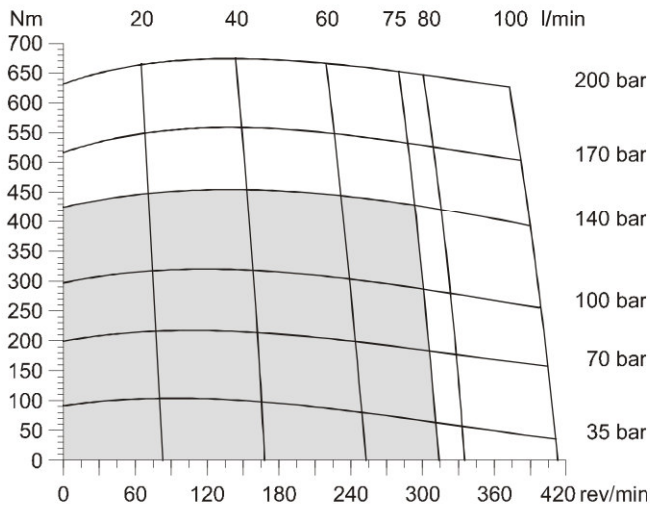

**TF 280**

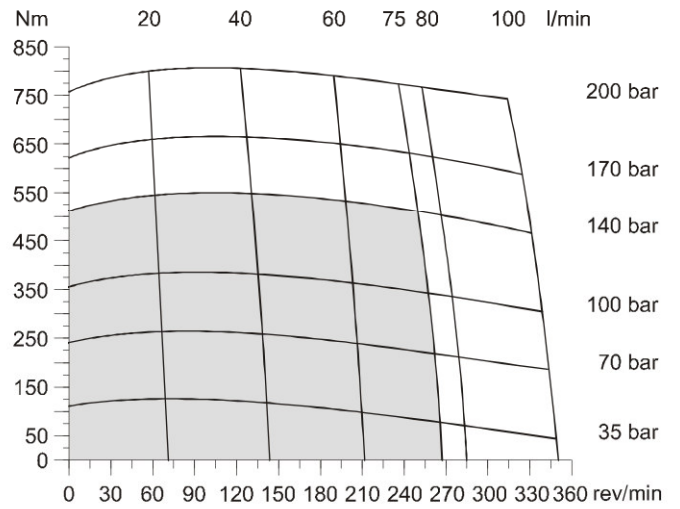

**TF 360**

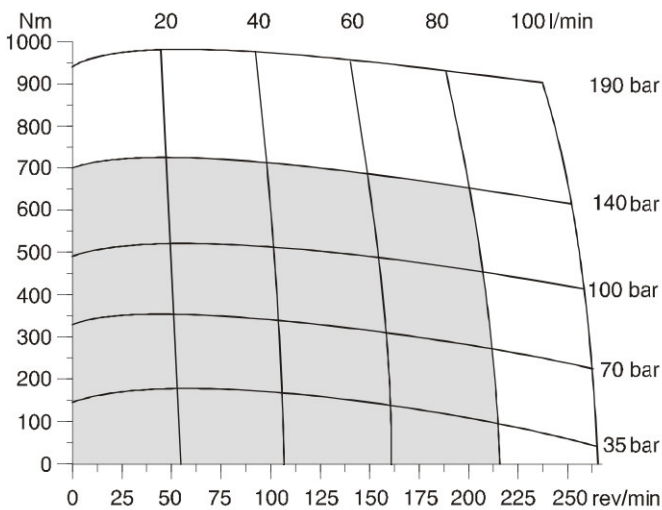

**TF 405**

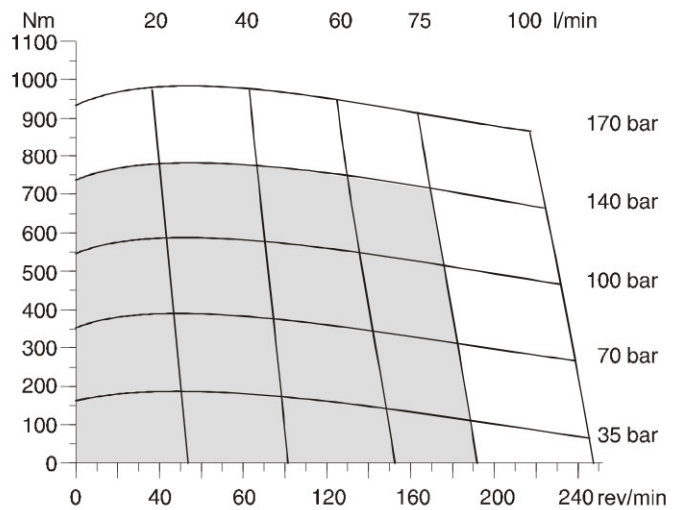

**TF475**

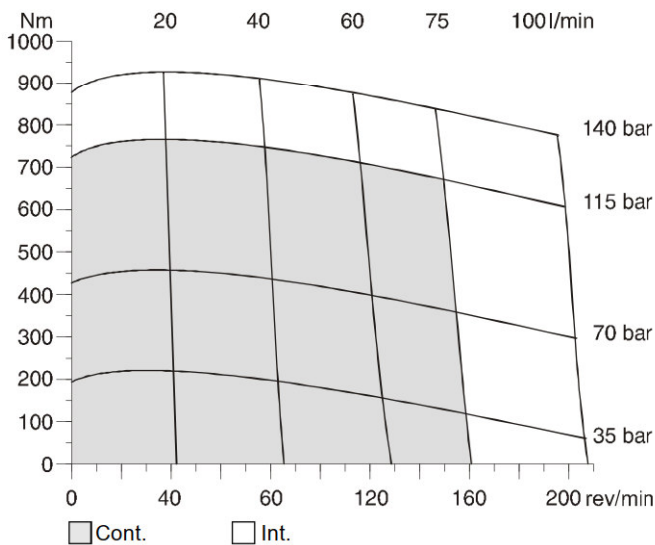

int. =  
 Intermittierende Werte maximal: 10% von jeder Betriebsminute.  
 Intermittent operation rating applies to 10% of every minute.  
 Fonctionnement interm.: 10% max. de chaque minute d'utilisation.  
 Servizio intermittente: 10% max di ogni minuto di utilizzazione.

**Code E**

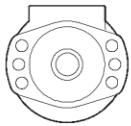

$$L_h = \frac{\left( \frac{670000}{F_R \cdot \left( 1.10 + \frac{L}{88\text{mm}} \right)} \right)^{3.3}}{n}$$

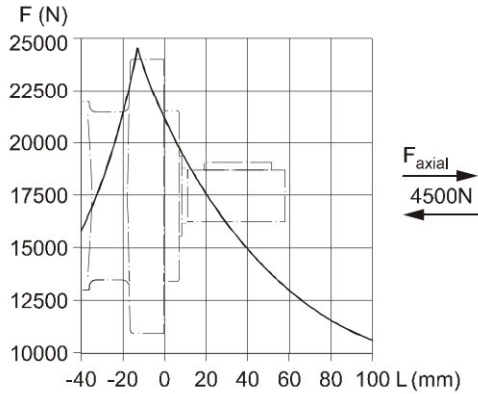

**Code M**

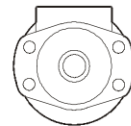

$$L_h = \frac{\left( \frac{670000}{F_R \cdot \left( 1.16 + \frac{L}{88\text{mm}} \right)} \right)^{3.3}}{n}$$

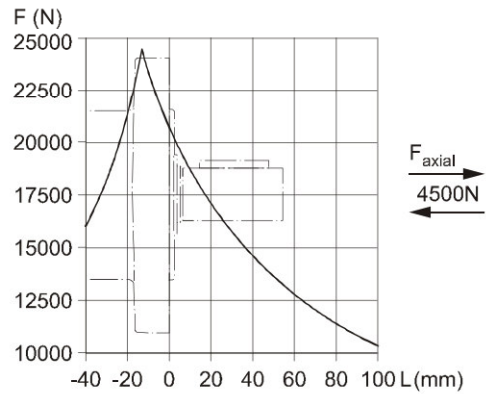

**Code H**



$$L_h = \frac{\left( \frac{670000}{F_R \cdot \left( 0.56 + \frac{L}{88\text{mm}} \right)} \right)^{3.3}}{n}$$

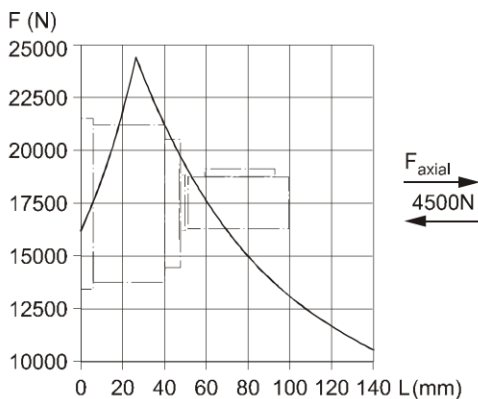

**Code V**

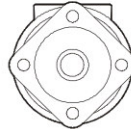

$$L_h = \frac{\left( \frac{670000}{F_R \cdot \left( 1.11 + \frac{L}{88\text{mm}} \right)} \right)^{3.3}}{n}$$

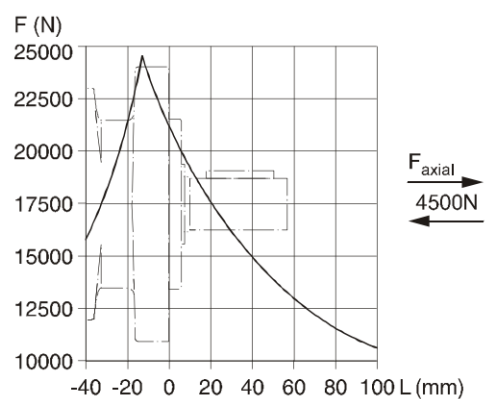

Die Lebensdauer der Radiallager ( $L_h$  in Stunden) lässt sich nach folgender Formel berechnen. Die Größe  $F_R$  ist durch die mechanische Festigkeit der Abtriebswelle begrenzt (siehe Diagramm). Das Maß "L" ist das Längenmaß vom Gehäuseflansch bis zum Angriffspunkt der Radialkraft  $F_R$ .

La durée de vie des roulements radiaux ( $L_h$  en heures) peut être calculée par les formules suivantes. La grandeur  $F_R$  est limitée par les résistances mécaniques de l'arbre de sortie (voir diagramme). La cote "L" est la longueur entre la bride du carter jusqu'au point d'appui de l'effort radial  $F_R$ .

Life time ( $L_h$  in hours) of the radial bearings can be calculated with the following formula. The value  $F_R$  is limited by the mechanical strength of the shaft (see diagram). The measurement "L" is the length from the housing flange up to the point of impact of the radial force  $F_R$ .

La durata dei cuscinetti ( $L_h$  in ore) può essere calcolata con la seguente formula. Il valore  $F_R$  è limitato dalla resistenza meccanica dell'albero (vedi diagramma). La quota "L" è la distanza tra la flangia del corpo ed il punto di applicazione della forza radiale  $F_R$ .

Vorstehende Formeln gelten für eine B10-Lebensdauer.  
 The preceding formulas are valid for a B10 duration of life.  
 Les formules précédentes sont valables pour une durée de vie B10.  
 Le formule precedenti sono valide per una durata della vita B10.

$L_h$  = h  
 $L$  = mm  
 $F_R$  = F (N)  
 $n$  = rev/min



**TF**  
 Serie  
 Series  
 Série  
 Serie

Schluckvolumen  
 Displacement  
 Cylindrée  
 Cilindrata

Gehäuse  
 Housing  
 Carter  
 Corpo motore

Anschluß  
 Ports  
 Plan de raccordement  
 Conessioni

Welle  
 Shaft  
 Arbre  
 Albero

Drehrichtung  
 Direction of rotation  
 Direction de rotation  
 Direzione di rotazione

Option  
 code

For further options  
 different to standard  
 'AAAB' see page 57.

Code	cm <sup>3</sup> /rev
0080	81
0100	100
0130	128
0140	141
0170	169
0195	195
0240	237
<b>0280</b>	280
0360	364
0405	405
0475	477

Code	Housing
E	
M	
<b>H</b>	
V <sup>1)</sup>	

Code	Front port
W	G 1/2
V	7/8-14 UNF O-Ring
N <sup>2)</sup>	Universal- M8x13
K <sup>3)</sup>	Universal- M6x12

<sup>2)</sup> Nicht verfügbar für Gehäuse "H"  
 Not possible for housing "H"  
 Pas disponible pour carter "H"  
 Non disponibile con il corpo co-  
 dice "H"

<sup>3)</sup> Nicht verfügbar für Gehäuse "M,  
 E, V"  
 Not possible for housing "M, E,  
 V"  
 Pas disponible pour carter "M,  
 E, V"  
 Non disponibile con il corpo co-  
 dice "M, E, V"

Code	Rear port
Y	G 1/2 Axial
A	7/8-14 UNF Axial
X	G 1/2 Radial
<b>B</b>	7/8-14 UNF Radial
L	Universal Radial M8x13

<sup>1)</sup> Nur verfügbar mit Endanschluß  
 Only possible with rear port  
 Possible seulement avec orifice  
 arrière  
 Possible solo con connessioni  
 Posteriori

Code	Front port
0	 Standard
1	

Code	Rear port
0	 Standard
1	

Code	Shaft
26	25
47	25.4
41	6B SAE
44	Pitch 12/24
45	31.75
08	
<b>46</b>	32