

SOLENOID VALVES

SV10-21 Poppet, 2-Way, Normally Open

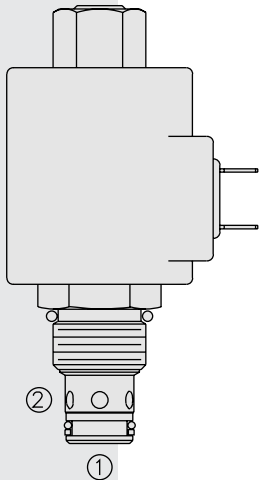

DESCRIPTION

A solenoid-operated, 2-way, piloted, poppet-type, normally open, screw-in, hydraulic cartridge valve designed for low leakage in load-holding applications.

OPERATION

When de-energized, the **SV10-21** allows flow from ② to ①. Flow from ① to ② is severely restricted in this mode. If the ① to ② path is required, see model SV10-23, page 1.053.1.

When energized, the valve's poppet closes on its seat, blocking flow in the ② to ① direction. In this mode the cartridge will allow ① to ② flow after overcoming the solenoid force (requires 3.4 to 10.3 bar / 50 to 150 psi).

Operation of Manual Override Option: To override, push and hold override button.

FEATURES

- Continuous duty-rated solenoid.
- Hardened seat for long life and low leakage.
- Optional coil voltages and terminations.
- Efficient wet-armature construction.
- Cartridges are voltage interchangeable.
- Unitized, molded coil design.
- Industry common cavity.
- Manual override option.
- Optional waterproof E-Coils rated up to IP69K.

SYMBOLS

USASI:

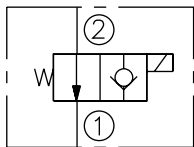

ISO:

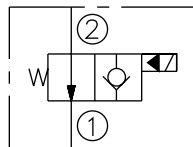

PERFORMANCE (Cartridge Only)

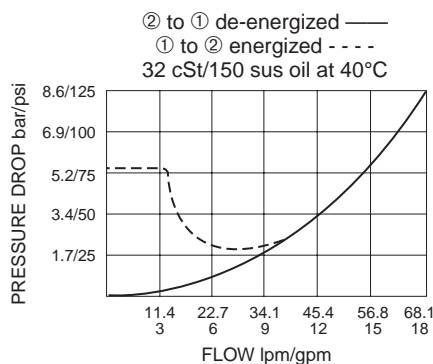

RATINGS

Operating Pressure: 207 bar (3000 psi)

Proof Pressure: 345 bar (5000 psi)

Flow: See Performance Chart

Internal Leakage: 0.15 cc/minute (3 drops/minute) max. at 207 bar (3000 psi)

Temperature: -40 to 120°C with standard Buna seals

Coil Duty Rating: Continuous from 85% to 115% of nominal voltage

Response Time: First indication of change of state with 100% voltage supplied at 80% of nominal flow rating: Energized: 80 msec.; De-energized: 30 msec.

Initial Coil Current Draw at 20°C: Standard Coil: 1.67 amps at 12 VDC; 0.18 amps at 115 VAC (full wave rectified).

E-Coil: 1.7 amps at 12 VDC; 0.85 amps at 24 VDC

Minimum Pull-in Voltage: 85% of nominal at 207 bar (3000 psi)

Filtration: See page 9.010.1

Fluids: Mineral-based or synthetics with lubricating properties at viscosities of 7.4 to 420 cSt (50 to 2000 sus); See Temperature and Oil Viscosity, page 9.060.1

Installation: No restrictions; See page 9.020.1

Cavity: VC10-2; See page 9.110.1

Cavity Tool: CT10-2XX; See page 8.600.1

Seal Kit: SK10-2X-T; See page 8.650.1

Coil Nut: Part No. 7004420;

For E-coils manufactured prior to 1-1-04, see page 3.400.1 for coil nut info.

DIMENSIONS

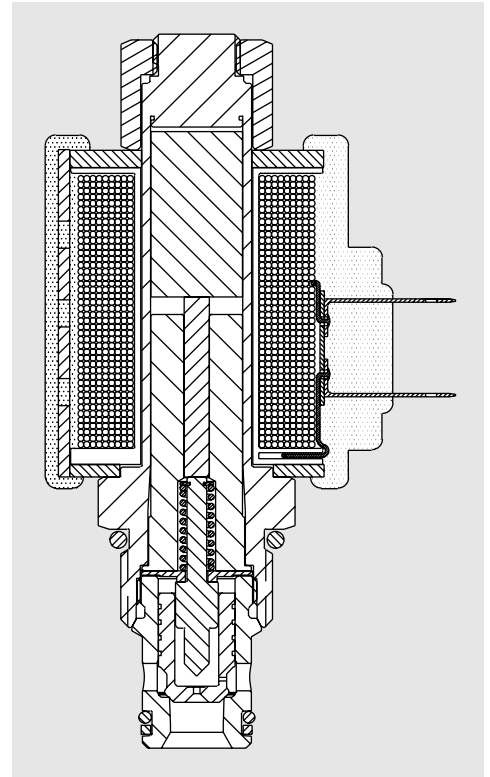
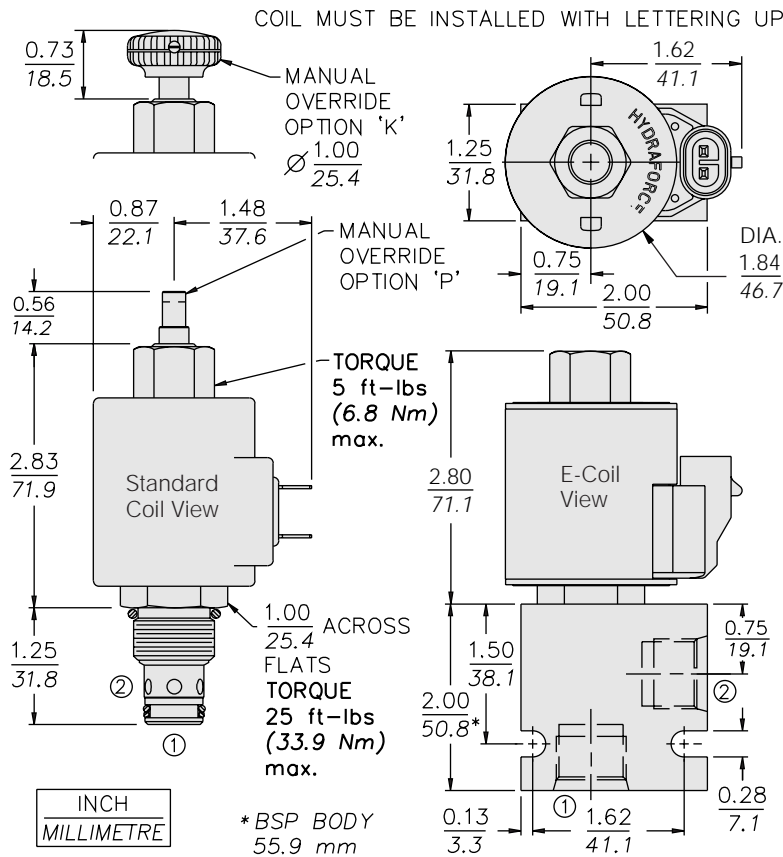

MATERIALS

Cartridge: Weight: 0.16 kg. (0.35 lbs.) Steel with hardened work surfaces. Zinc-plated exposed surfaces. Buna N O-rings and polyester elastomer back-up standard.

Standard Ported Body: Weight: 0.16 kg. (0.35 lbs.) Anodized high-strength 6061 T6 aluminum alloy, rated to 207 bar (3000 psi). Ductile iron bodies available; dimensions may differ. See page 8.010.1

Standard Coil: Weight: 0.27 kg. (0.60 lbs.) Unitized thermoplastic encapsulated, Class H high temperature magnetwire. See page 3.200.1

E-Coil: Weight: 0.41 kg. (0.9 lbs.) Fully encapsulated with rugged external metal shell. Rated up to IP69K with integral connectors. **Note: See page 3.400.1 for all E-Coil retrofit applications.**

TO ORDER

SV10-21P-0-N-24EG

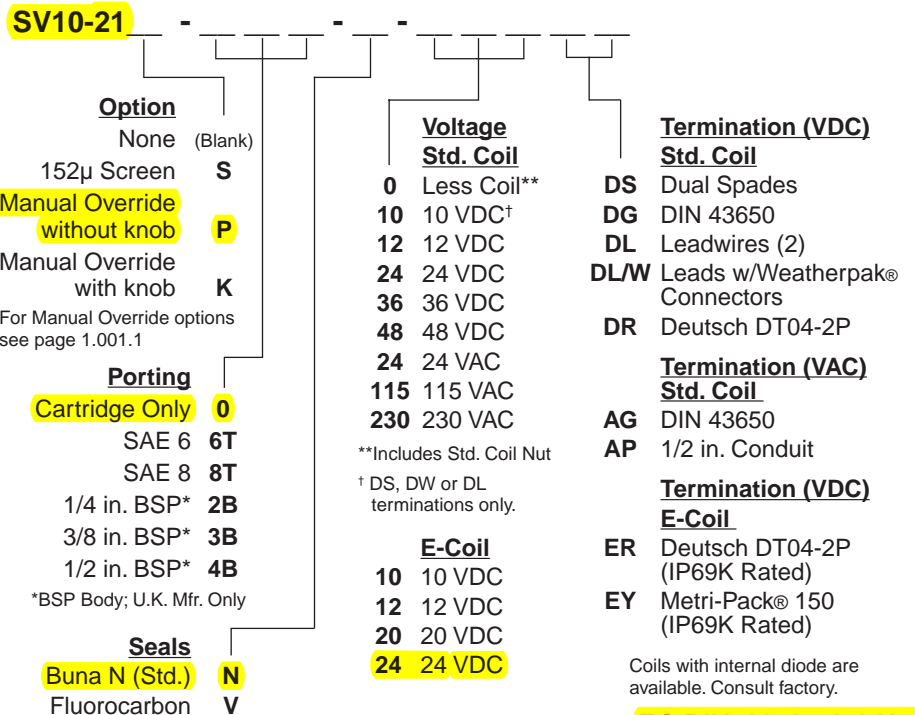

Coils with internal diode are available. Consult factory.

EG DIN43650 mit 2 Kontakten