

Motoren der M Serie

EIGENSCHAFTEN

Motorausführung	Schluckvolumen (ccm/U.)	Max. zulässige Dauerdrehzahl (1) (U/min.)	Max. zulässige Spitzendrehzahl (1) (U/min.)	Max. Schluckstrom (L/min.)	Max. Drehmoment in Abhängigkeit des Drucks (Nm/bar)	Drehmoment bei 350 bar (Nm)	Theoretisch maximale Leistung bei 400 bar (kW)	Max. zulässiger Dauerdruck/ Spitzendruck (bar)	Gewicht (kg)
M 5_093840	5	8000	8800	40	0.08	28	26.6	400 / 450	4.4
M 12	12	8000	8800	96	0.19	67	64	400 / 450	5.5
M 18	18.0	8000	8800	144	0.29	100	96	400 / 450	5.5
M 25	24.9	6300	6900	157	0.40	139	104.5	400 / 450	11.5
M 28	27.7	6300	6900	175	0.44	154	116.3	400 / 450	11.5
M 32	32.1	6300	6900	202	0.51	179	134.8	400 / 450	11.5
M 41	41.1	5600	6200	230	0.65	229	153.4	400 / 450	11.5
M 45	45.4	5000	5500	227	0.72	253	151.3	400 / 450	18
M 50	50.3	5000	5500	252	0.80	280	167.6	400 / 450	18
M 63	63	5000	5500	315	1.00	351	210	400 / 450	18
M 80	80.4	4500	5000	362	1.28	448	241.2	400 / 450	23
M 90	90	4500	5000	405	1.43	501	270	400 / 450	23
M 108	108.3	4000	4400	433	1.72	603	288.8	400 / 450	23
M 108 R (2)	108.3	3400	4500	368	1.72	603	245.4	400 / 450	35
M 125	125.4	3400	4500	426	2.00	699	284.2	400 / 450	35
M 160	160	3600	4000	576	2.55	891	384	400 / 450	48.5
M 180	180.6	3600	4000	650	2.87	1006	433.4	400 / 450	48.5

(1) Für höhere Drehzahlen nehmen Sie bitte Kontakt mit uns auf.

(2) Der M108 R Motor entspricht den Abmessungen des M125 Motors.

► Max. zulässige Kräfte

Motorausführung	5	12	18	25	28	32	41	45	50	63	80	90	108	108 R	125	160	180
Fr Drehzahl	710	2800	4000	6000	6200	6500	7000	6500	7500	9000	10500	11000	11500	12500	14500	18000	20000
Fa Drehzahl/bar *	10	15	20	27	28	30	40	40	40	50	60	67	80	80	86	85	95

Fr: Radialkraft gemessen in der Mitte der Motorwelle

Fa: Axialkraft (wirkt axial auf die Motorwelle)

* Differenzdruck zwischen A und B.

Für weitere Kräfte nehmen Sie bitte mit uns Kontakt auf.

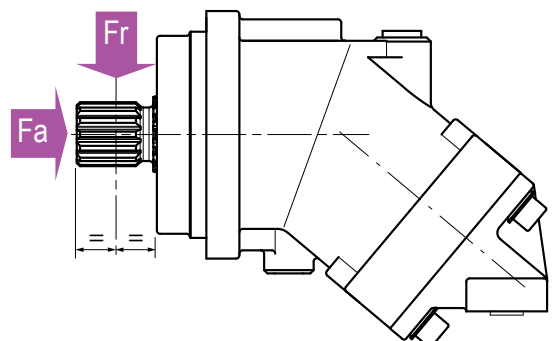

Konfigurator für M Motoren

M	...	A	M2
01	02	03	04	05	06	07	08	09	10

Um die Bestellbezeichnung Ihres Motors zu ermitteln wählen Sie aus den Optionen 02, 04, 05, 07, 08, 09 und 10 in der Auswahltablelle.

Motor	
01	Motor

Schluckvolumen	
02	5 12 18 25 28 32 41 45 50 63 80 90 108 108R 125 160 180

Flansch	
03	CETOP 2-Loch ISO 3019-2, 4-Loch-Flansch

Welle																			
04	DIN 5480 Zahnwelle	-	W25	W25	W25	W30	W30	W30	W30	W30	W30	W40	W40	W40	W45	W45	W50	W50	W1
		-	-	-	W30	W25	W25	-	W35	W35	W35	W35	-	-	W40	W40	-	-	W2
	DIN 6885 zylindrische Welle	Ø 18	Ø 25	Ø 25	Ø 25	Ø 30	Ø 30	Ø 30	Ø 30	Ø 30	Ø 30	Ø 40	Ø 40	Ø 40	Ø 45	Ø 45	Ø 50	Ø 50	D1
		-	Ø 20	-	Ø 30	Ø 25	Ø 25	-	Ø 35	Ø 35	Ø 35	-	-	-	Ø 40	-	-	-	D2

Anschlüsse A und B																					
05	SAE Flanschanschluss	Unten	0	-	-	-	-	•	•	•	•	•	•	•	•	•	•	•	•	L0	
		Hinten	0	-	-	-	•	•	•	•	•	•	•	•	•	•	•	•	•	•	M0
		Seitlich	0	-	-	-	•	•	•	•	•	•	•	•	•	•	•	•	•	•	N0
	Gewindeanschluss	Seitlich	1	-	-	-	•	•	•	•	•	•	•	•	•	•	•	•	•	•	N1
		Seitlich	0	-	•	•	•	•	•	•	•	•	•	•	•	-	-	-	-	-	Q0
		Seitlich	1	-	-	-	•	•	•	•	•	•	•	•	•	-	-	-	-	-	Q1
Hinten	0	•	•	•	•	•	•	•	•	•	•	•	•	-	-	-	-	-	P0		

0 = nicht möglich für Einsatz mit Ventilen
1 = Für Einsatz von Spülventilen

Leckölanschlüsse T1 und T2	
06	2 M2

Vorbereitet für Betrieb mit Drehzahlsensor																					
07	Ja	-	•	•	•	•	•	•	•	•	•	•	•	•	•	•	•	•	•	•	1
	Nein	•	•	•	•	•	•	•	•	•	•	•	•	•	•	•	•	•	•	•	•

Drehzahlsensor																						
08	Ja	-	•	•	•	•	•	•	•	•	•	•	•	•	•	•	•	•	•	•	•	1
	Nein	•	•	•	•	•	•	•	•	•	•	•	•	•	•	•	•	•	•	•	•	•

Ventile																						
09	Ohne	•	•	•	•	•	•	•	•	•	•	•	•	•	•	•	•	•	•	•	•	SV
	Mit Spülventil	-	-	-	•	•	•	•	•	•	•	•	•	•	•	•	•	•	•	•	•	VB

Tieftempereaturausführung																						
10	Ja (NBR)	-	•	•	•	•	•	•	•	•	•	•	•	•	•	•	•	•	•	•	•	N
	Nein (FKM)	•	•	•	•	•	•	•	•	•	•	•	•	•	•	•	•	•	•	•	•	•

BITTE BEACHTEN SIE: Der M5 Motor 093840 ist nur in einer Konfiguration lieferbar (siehe nächste Seite).

CETOP 2-Loch Flansch

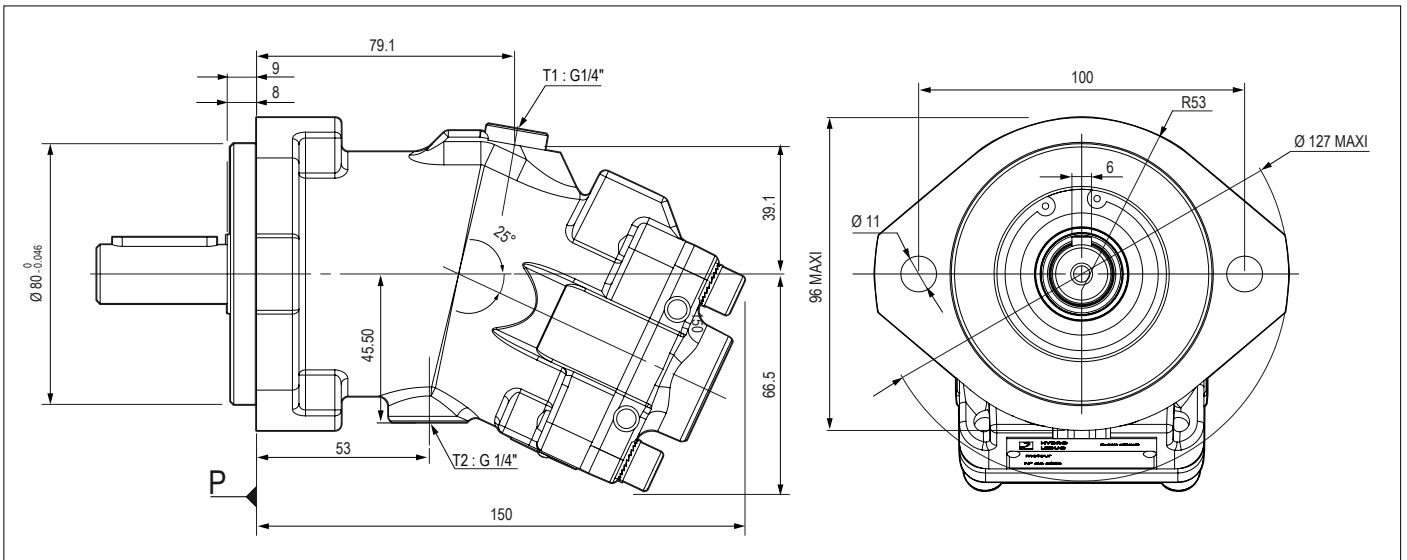

► **Wellenausführung**

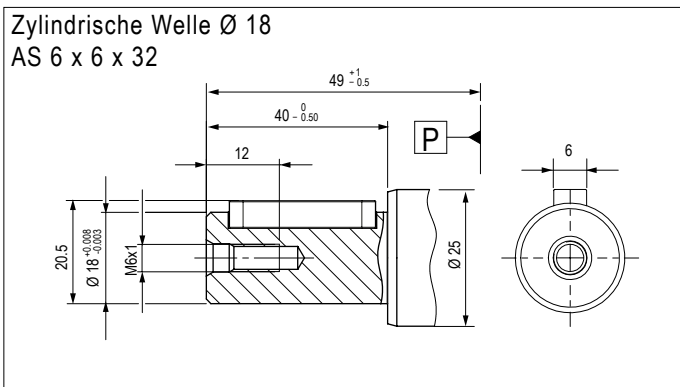

► **Eintritt / Austritt**

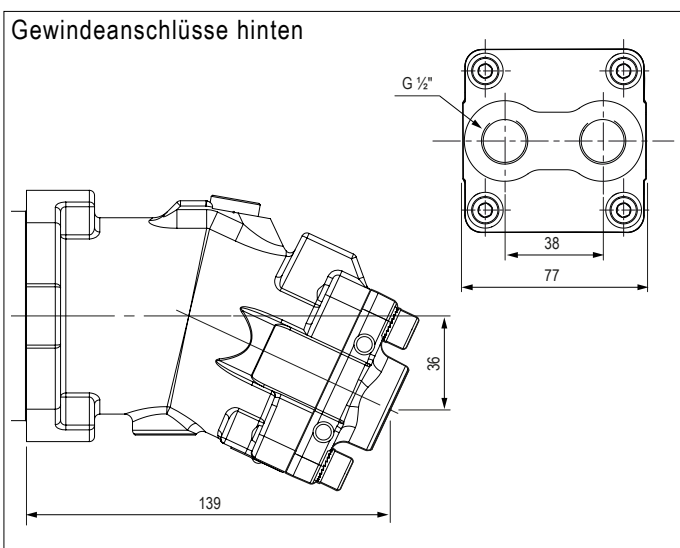

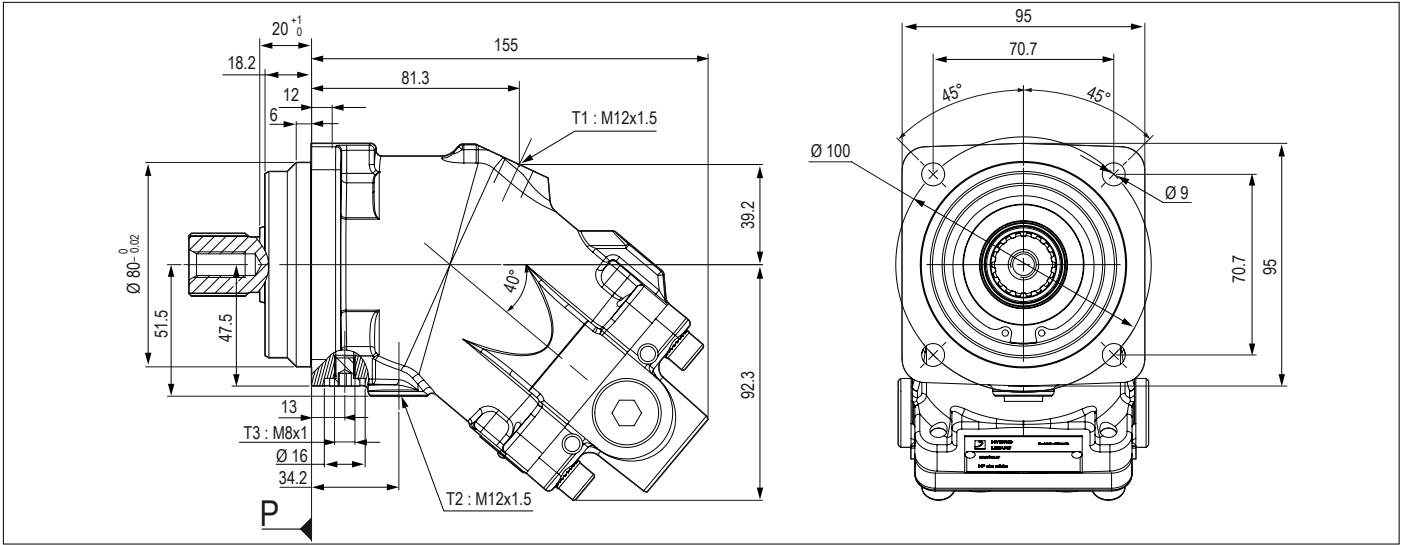

► Wellenausführung

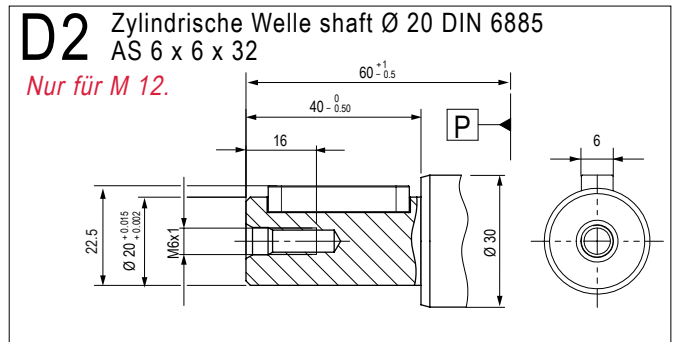
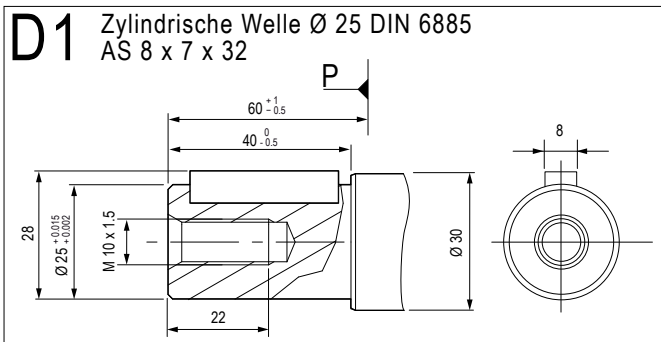
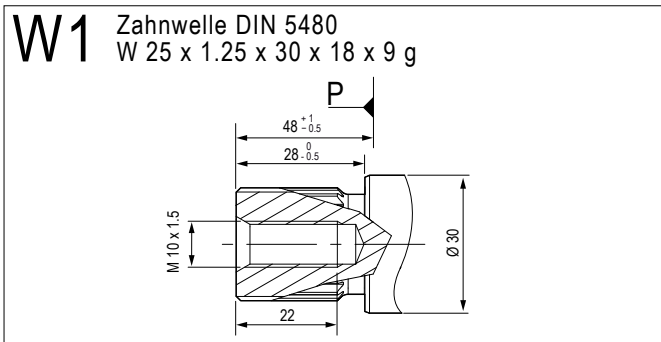

► Eintritt / Austritt

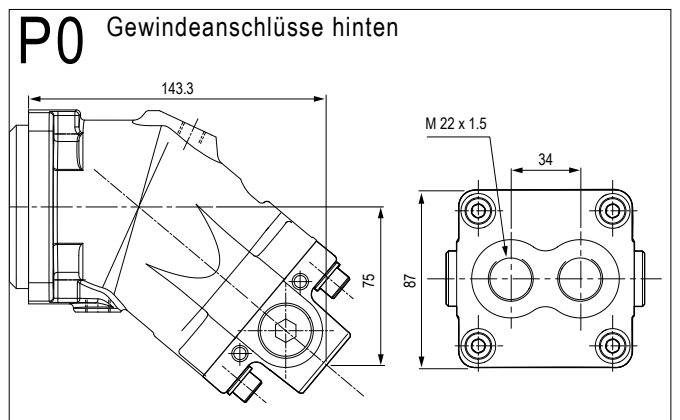
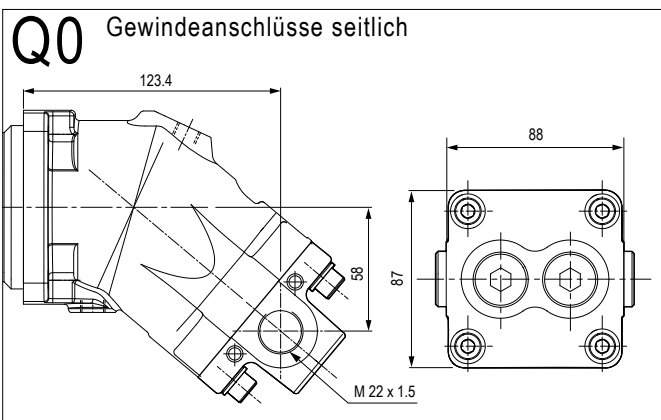

Maßangaben (mm) sind Anhaltswerte.

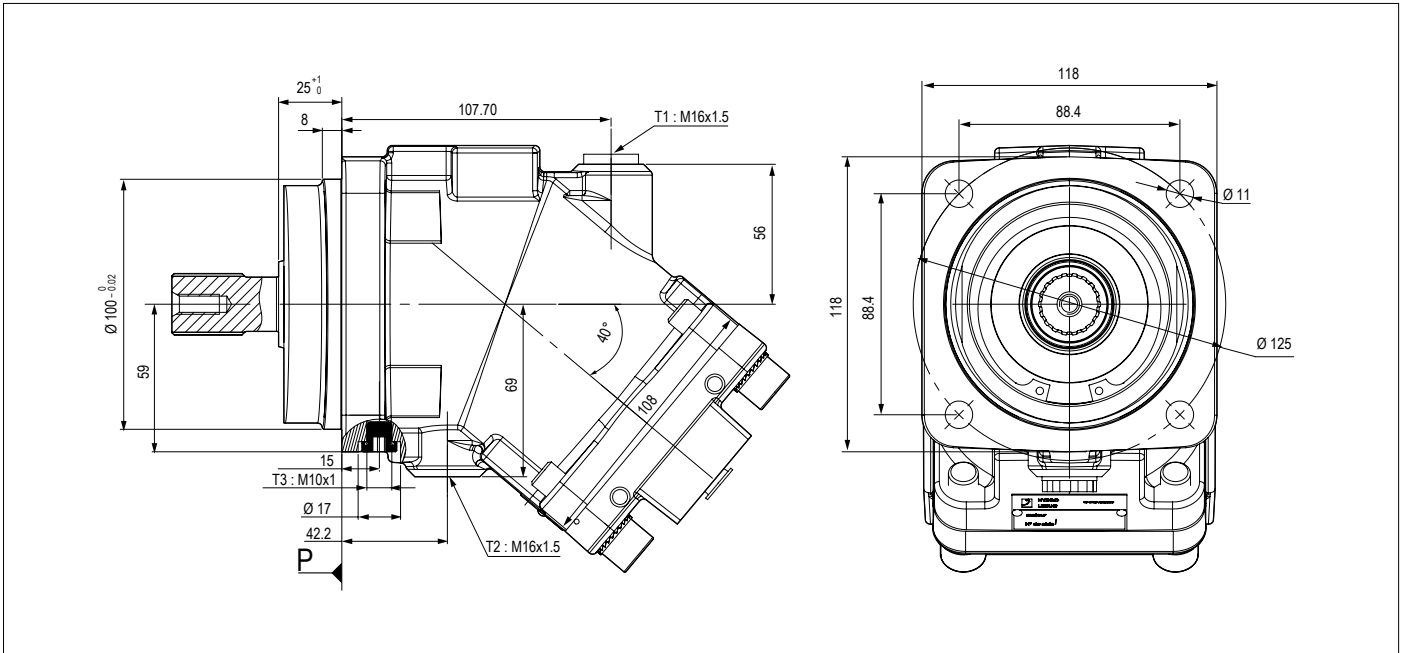

► Wellenausführung

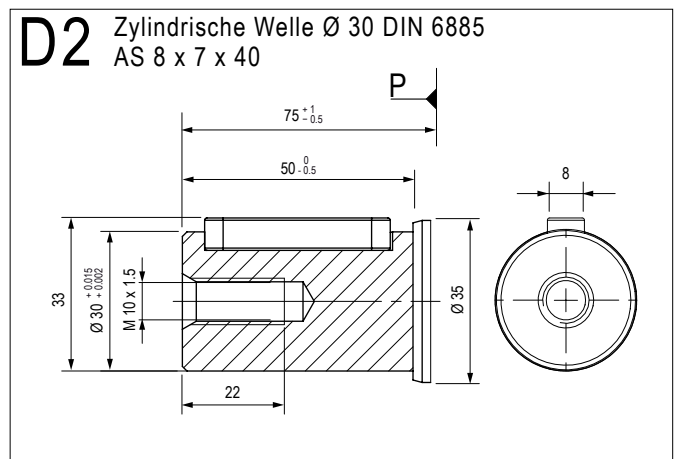
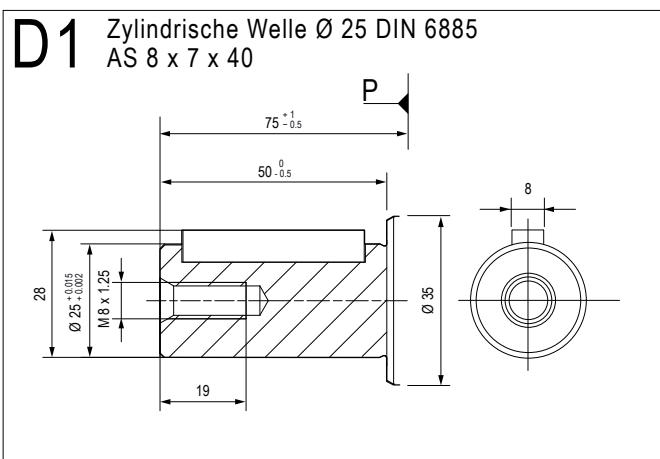
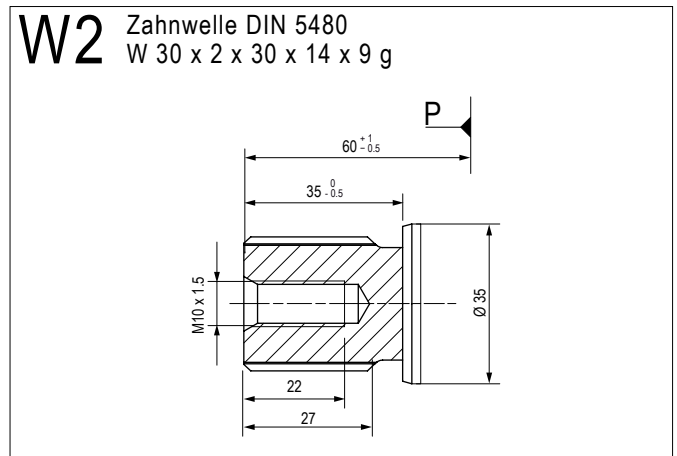
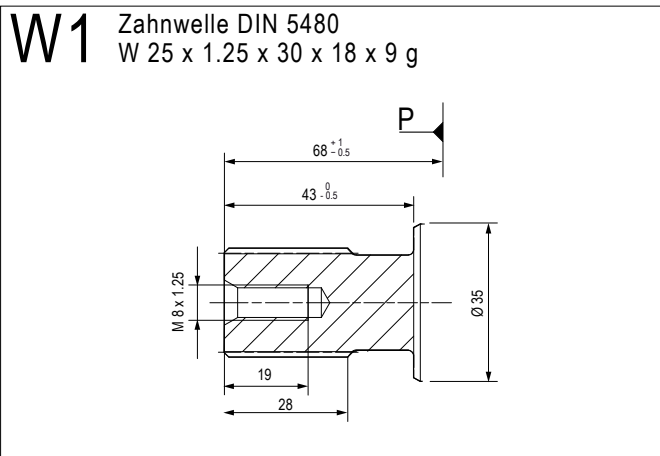

► **Eintritt / Austritt**

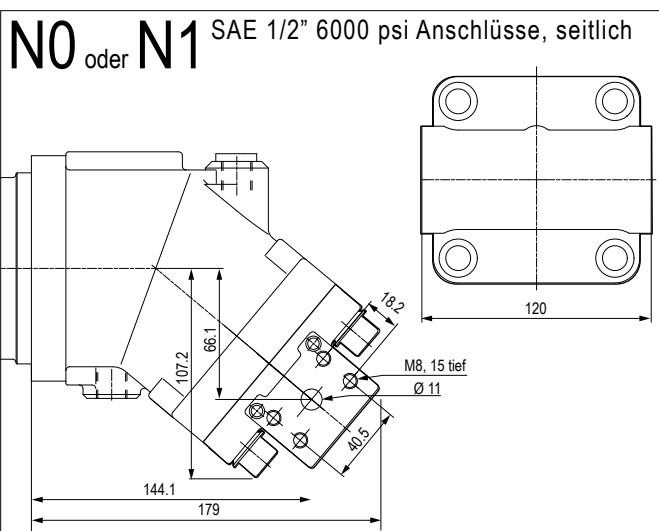
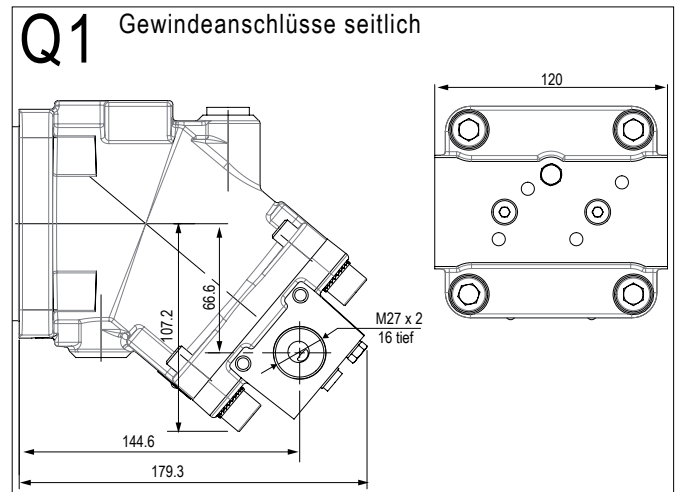
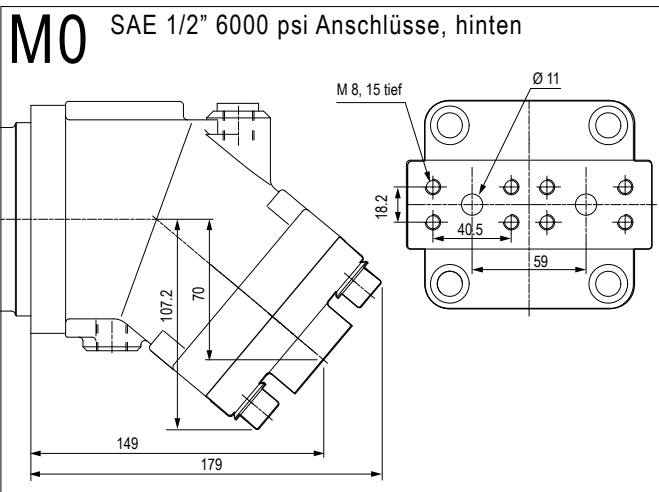
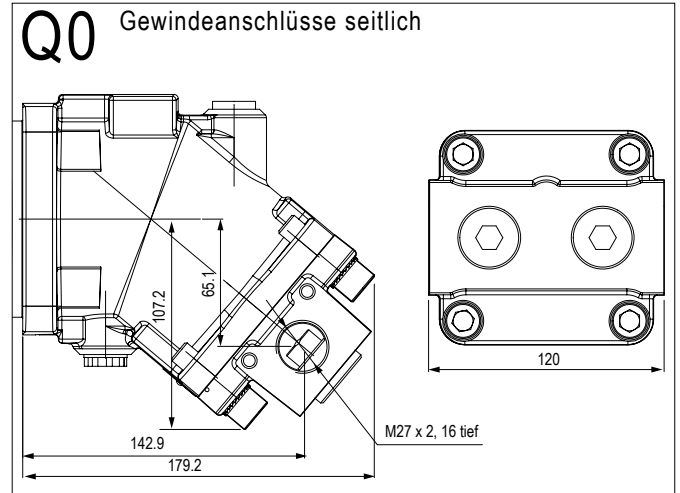
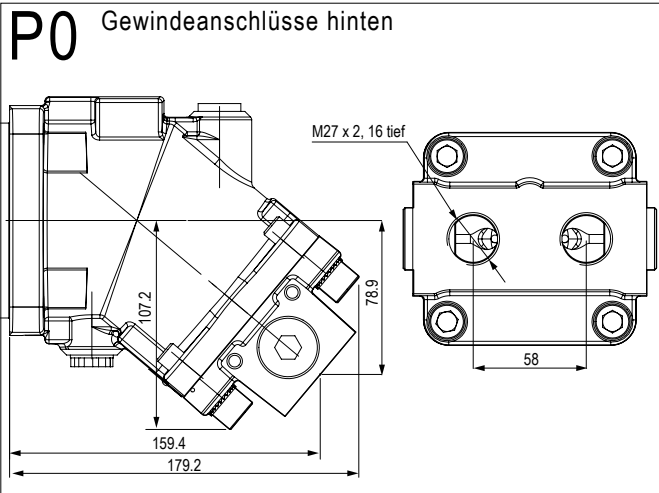

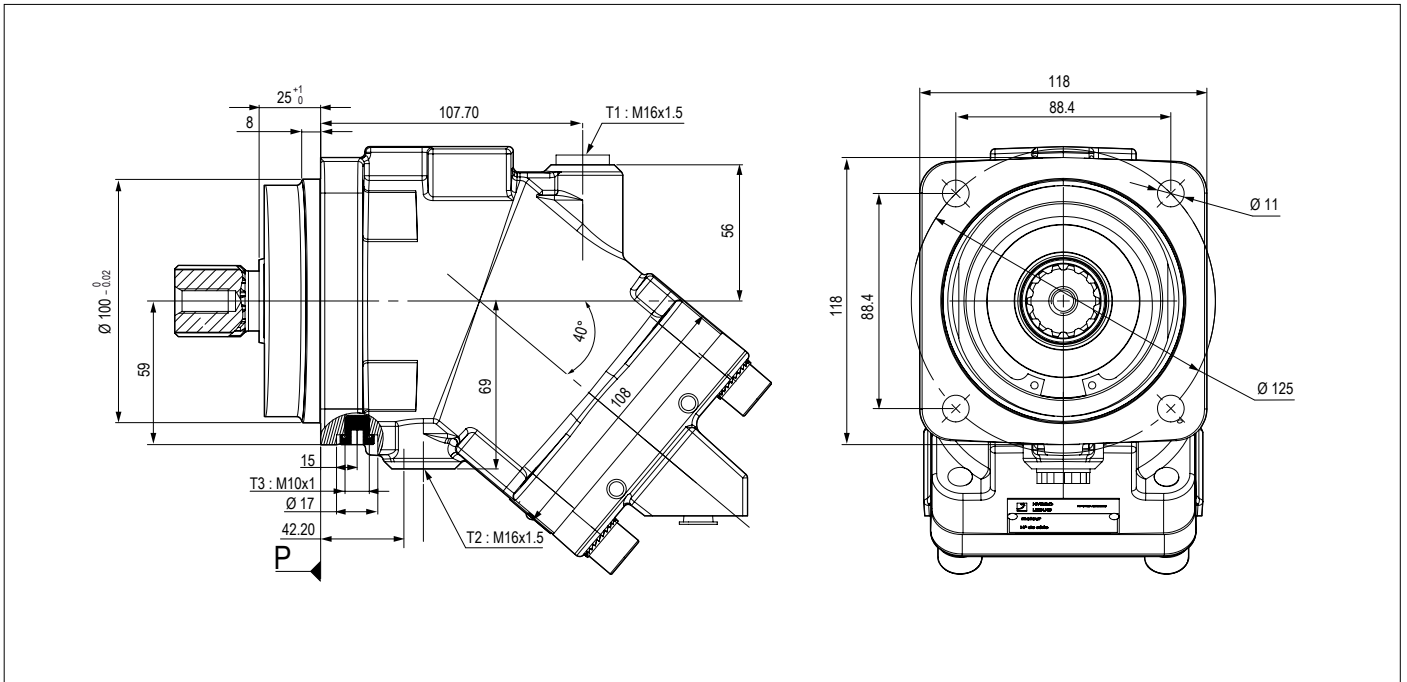

► Wellenausführung

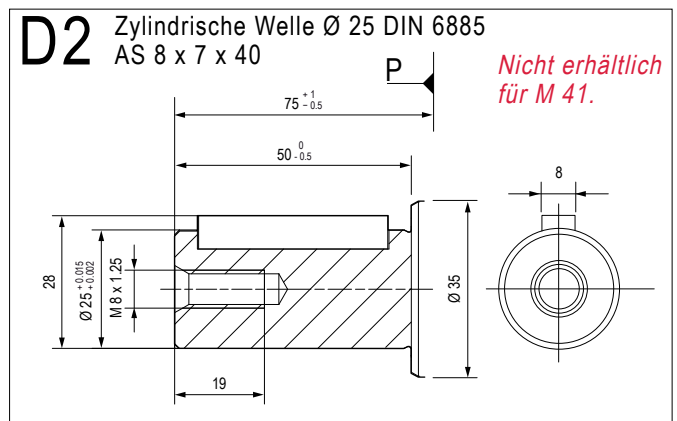
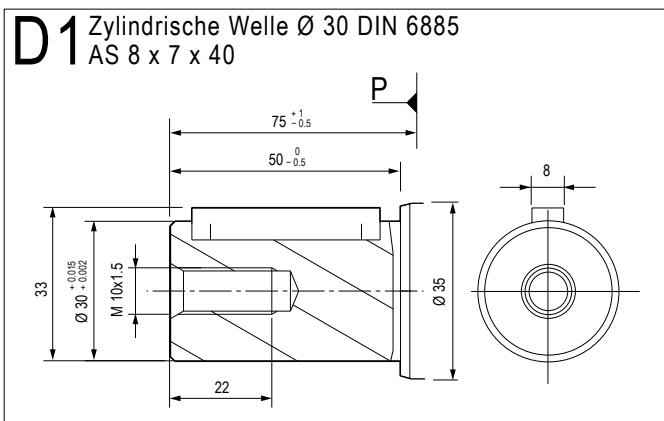
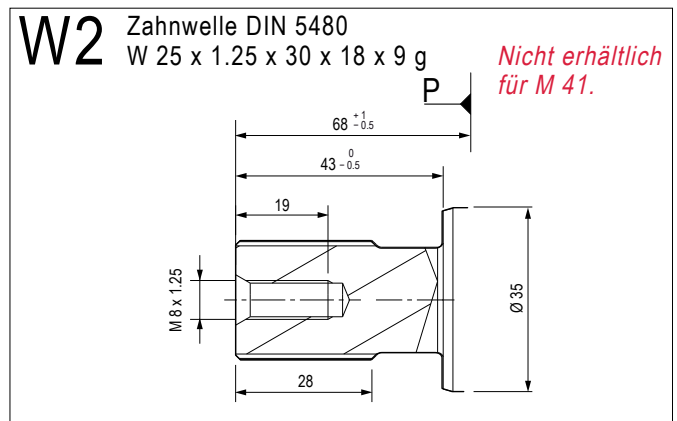
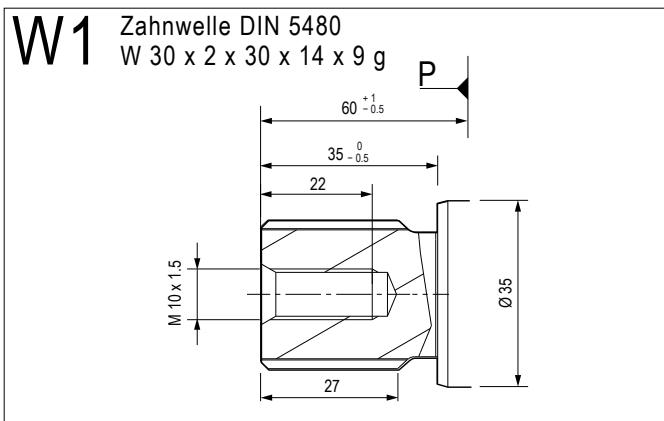

Maßangaben (mm) sind Anhaltswerte.

► Eintritt / Austritt

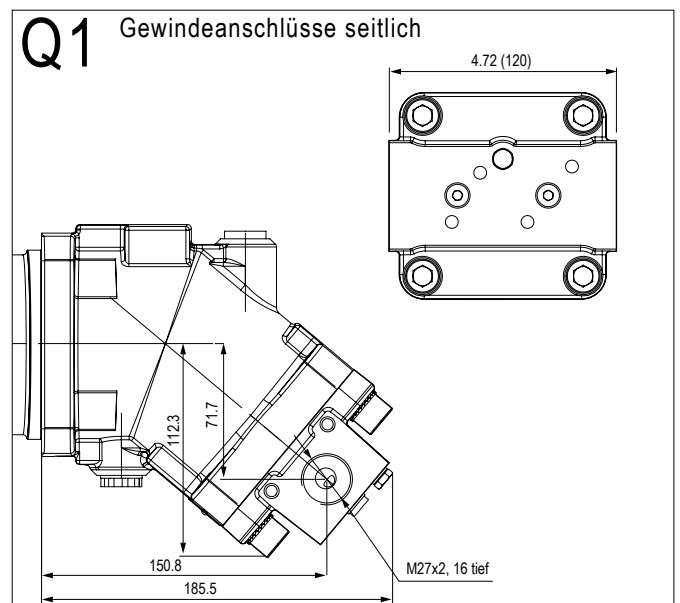
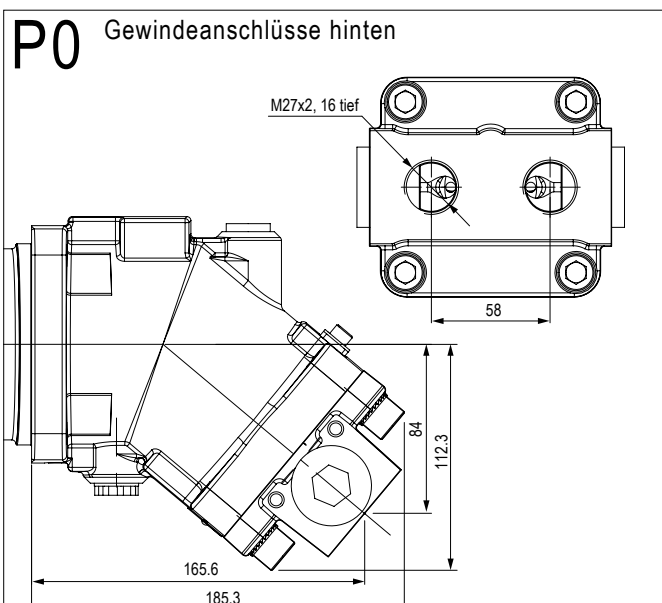
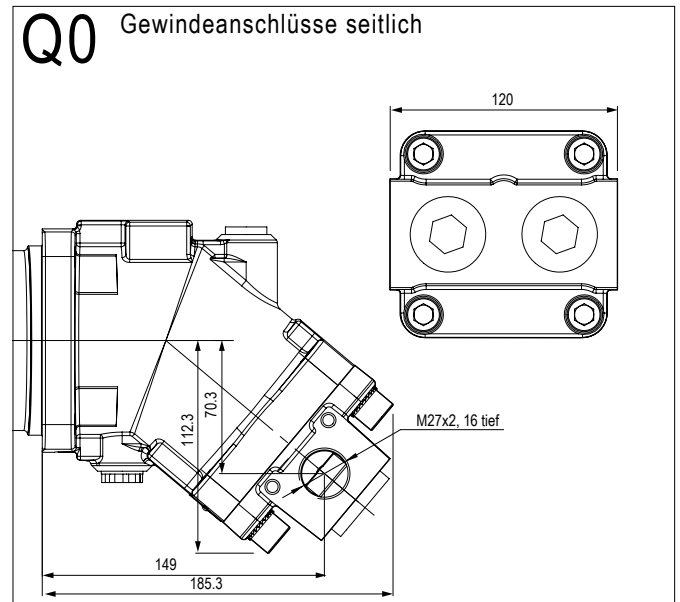
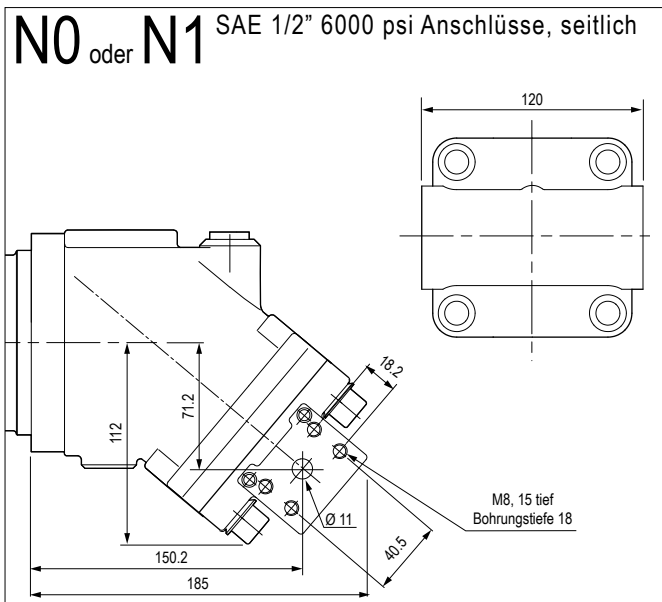
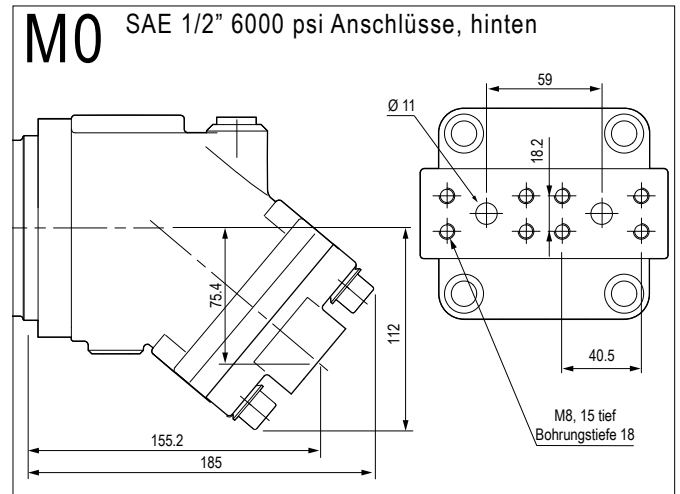
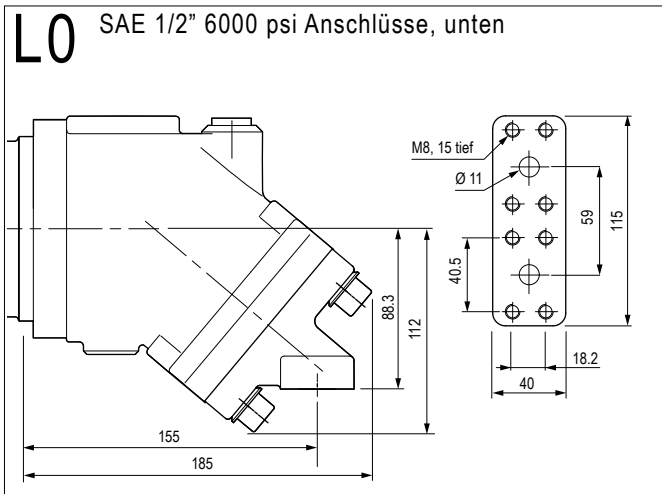

Maßangaben (mm) sind Anhaltswerte.

M Serie

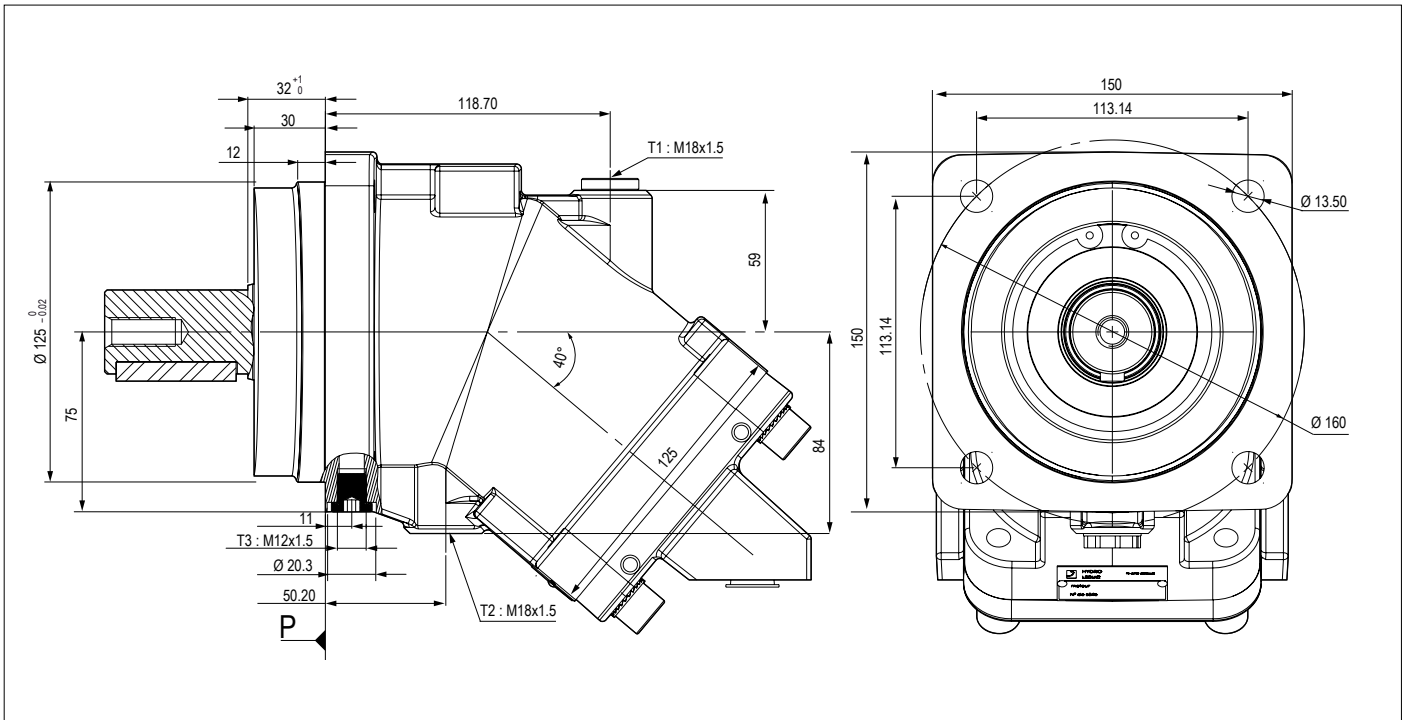

► Wellenausführung

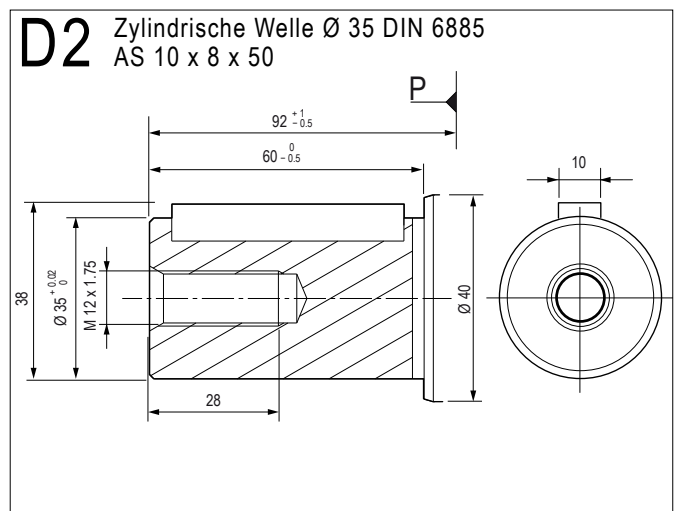
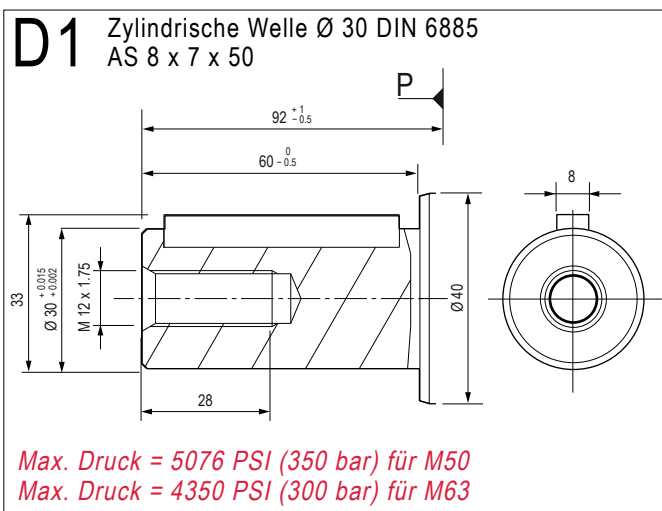
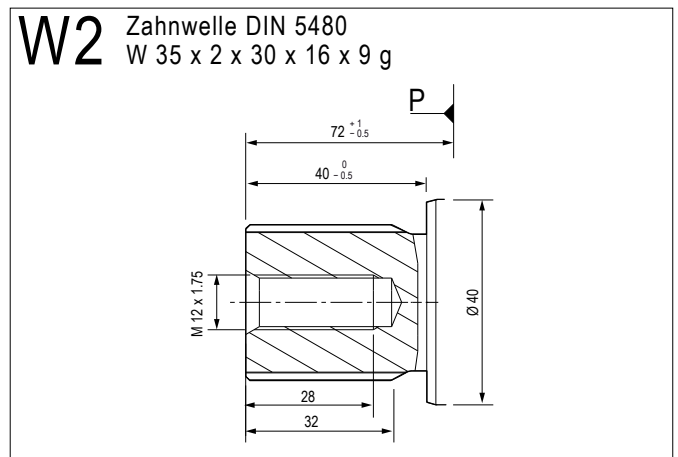
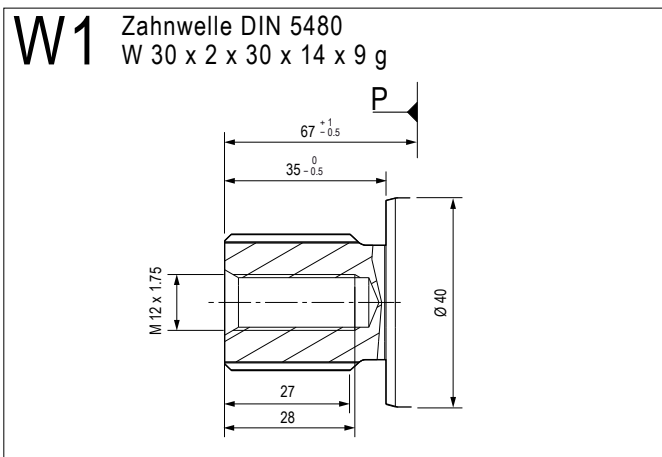

Maßangaben (mm) sind Anhaltswerte.

► Eintritt / Austritt

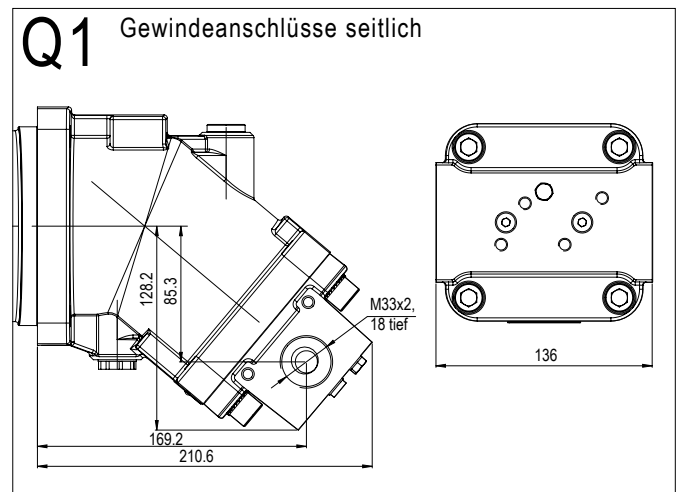
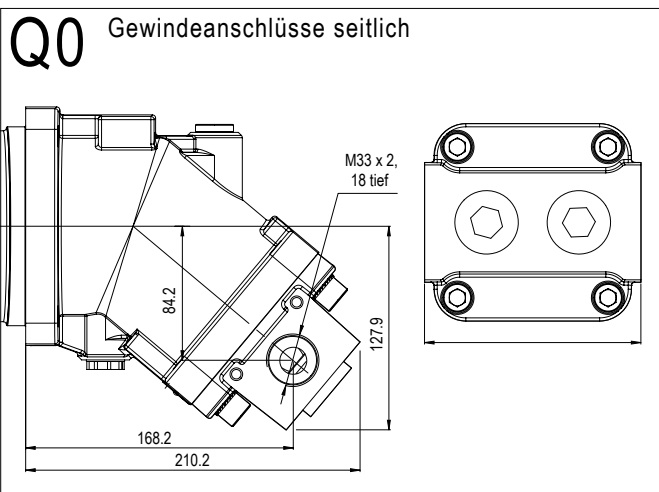
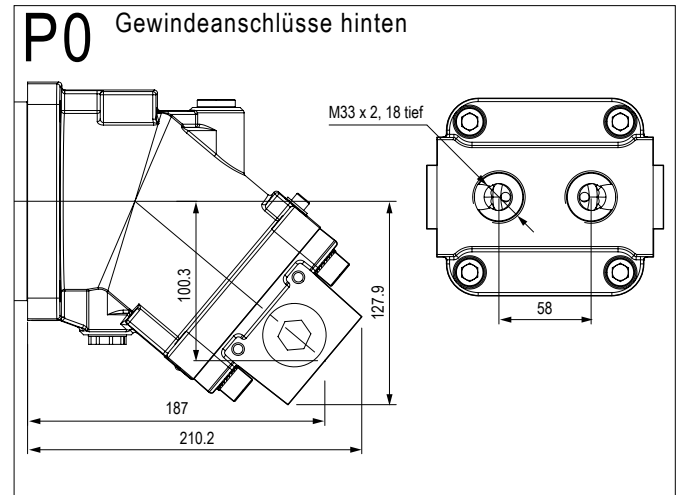
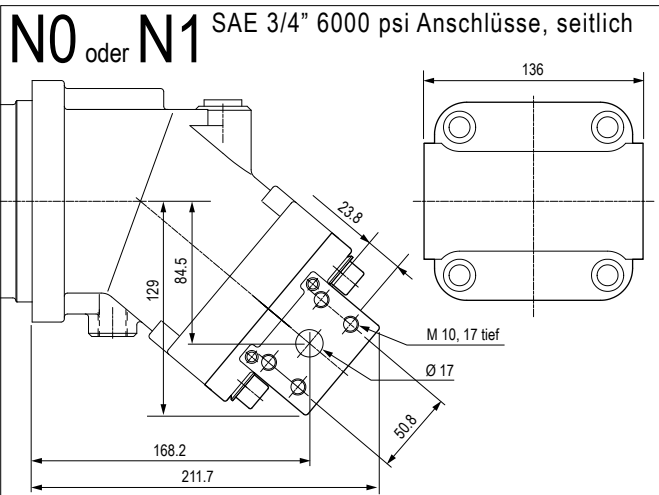
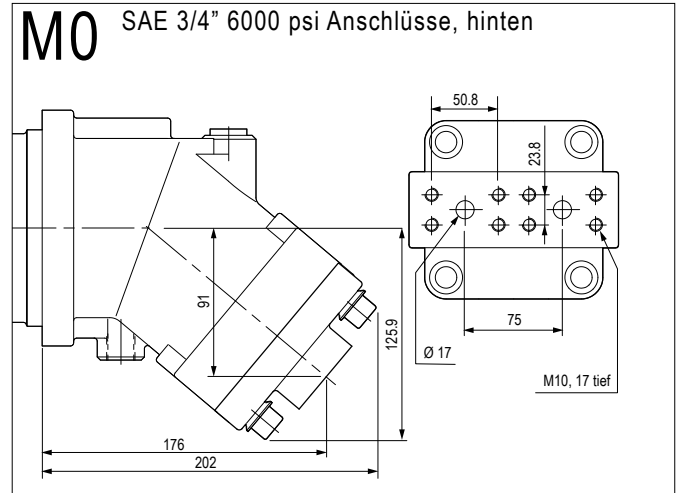
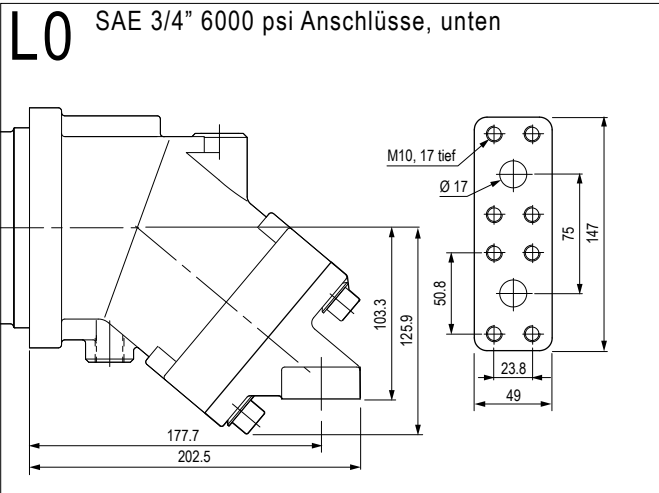

M Serie

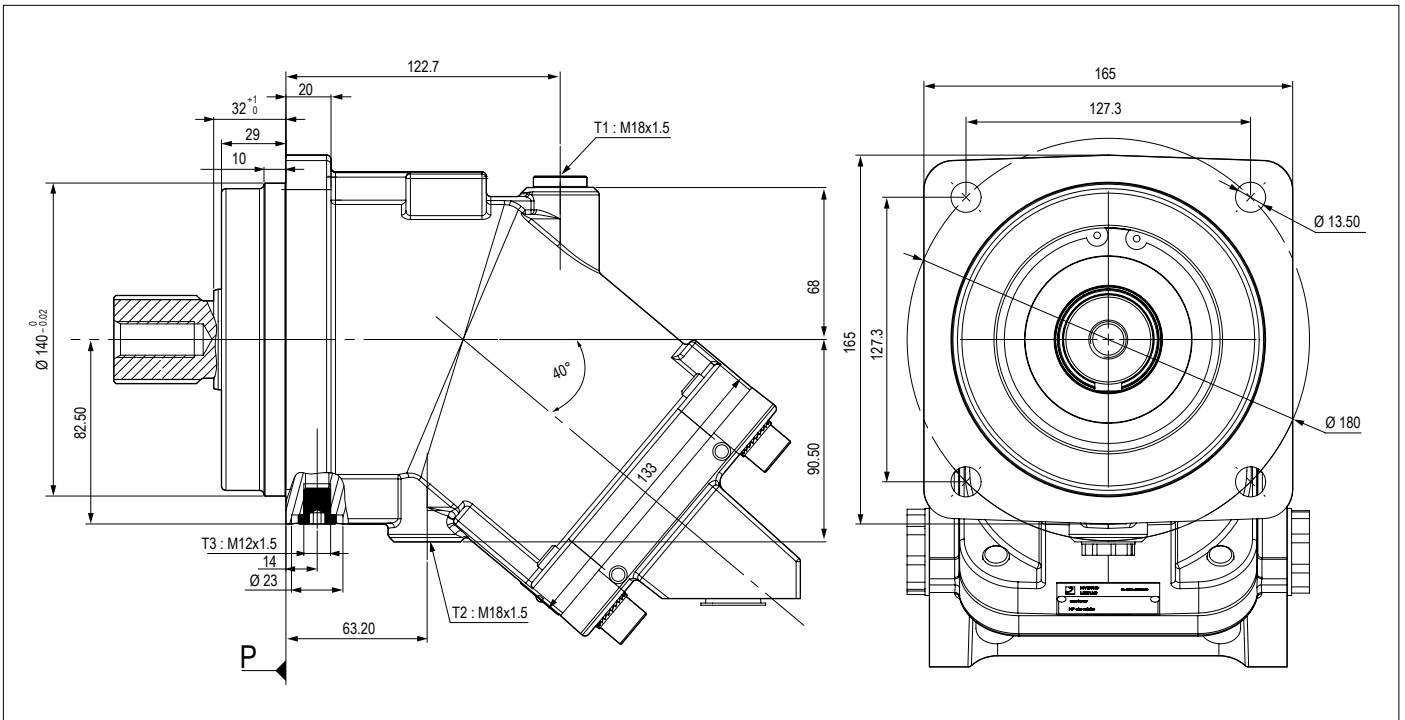

► Wellenausführung

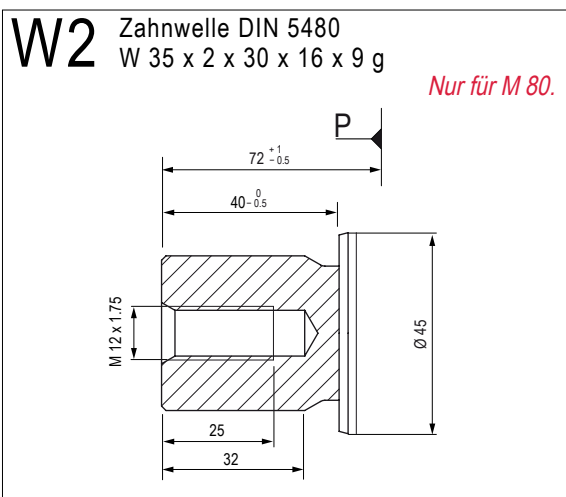
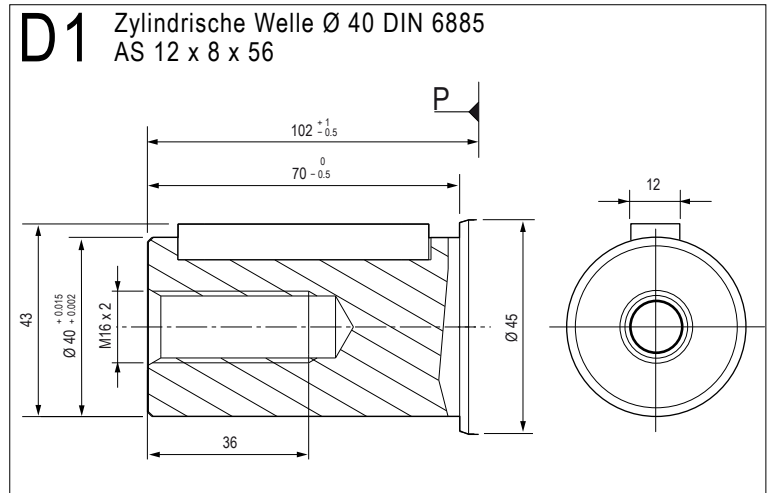
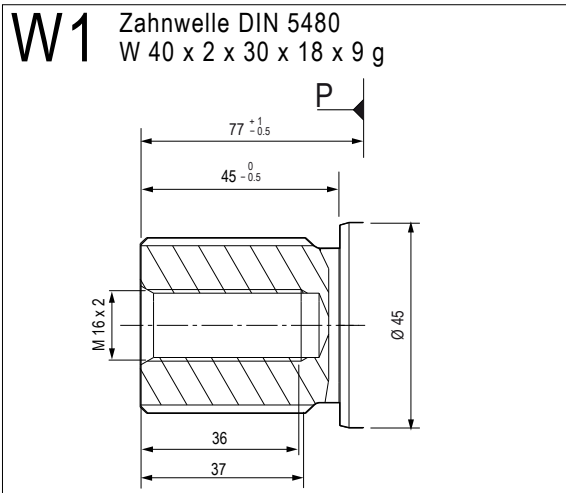

► Eintritt / Austritt

L0 SAE 1" 6000 psi Anschlüsse, unten

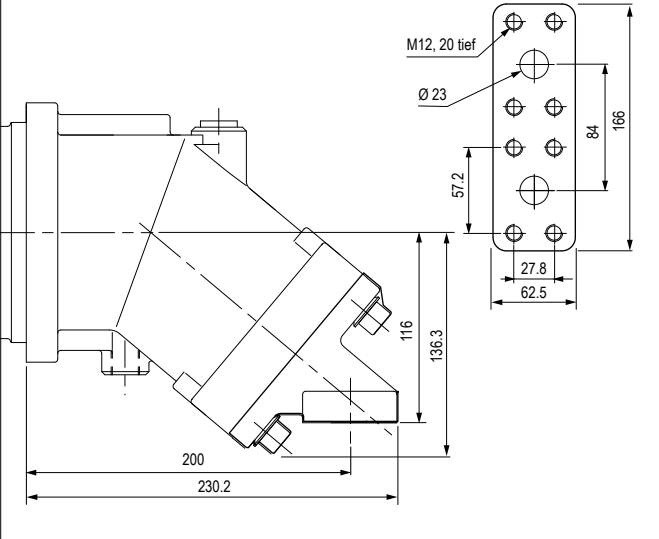

P0 Gewindeanschlüsse hinten

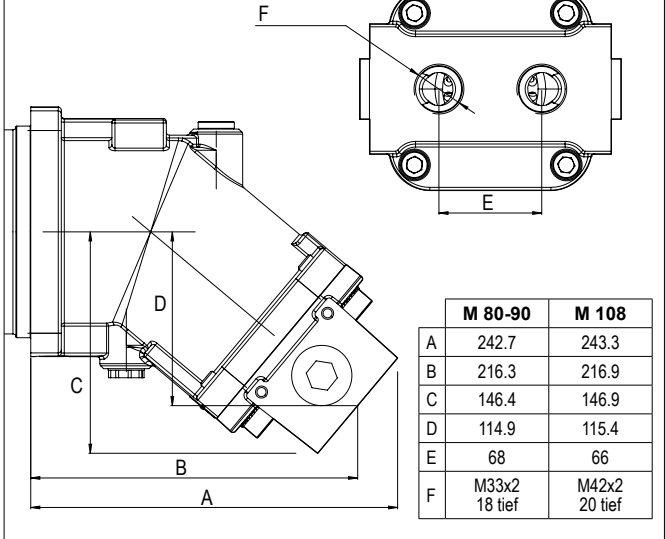

M0 SAE 1" 6000 psi Anschlüsse hinten

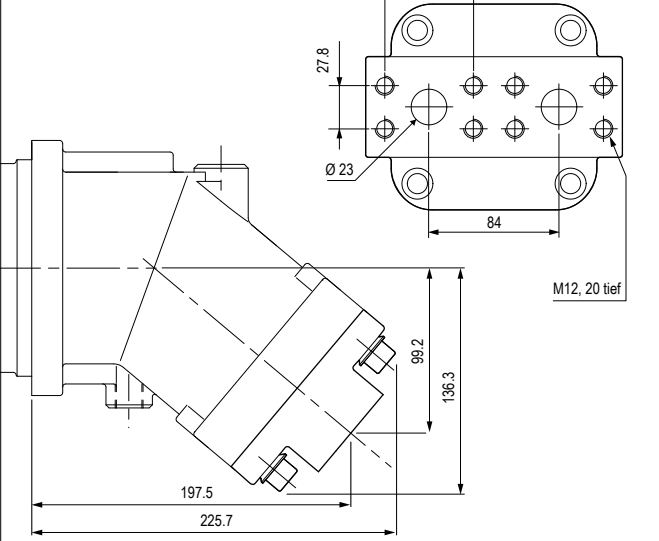

Q0 Gewindeanschlüsse seitlich

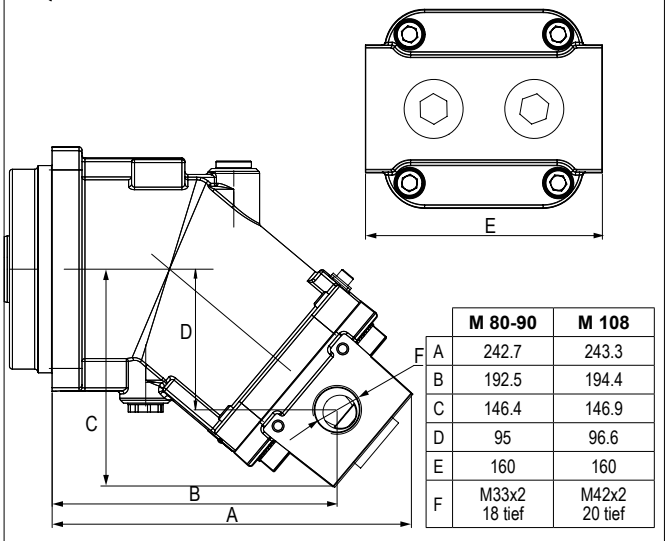

N0 oder **N1** SAE 1" 6000 psi Anschlüsse hinten

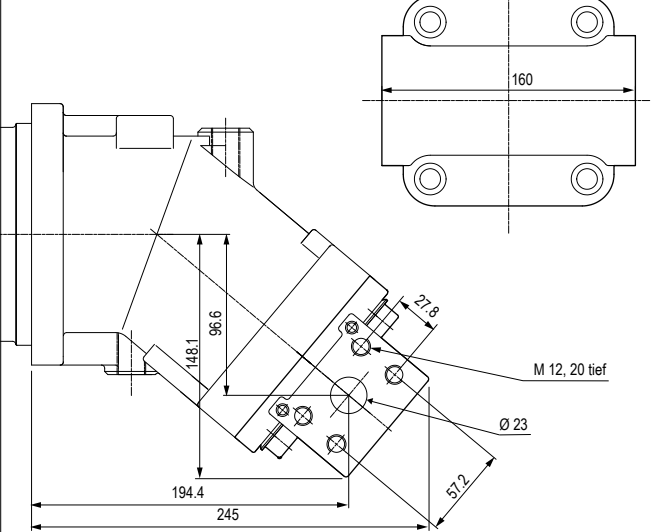

Q1 Gewindeanschlüsse seitlich

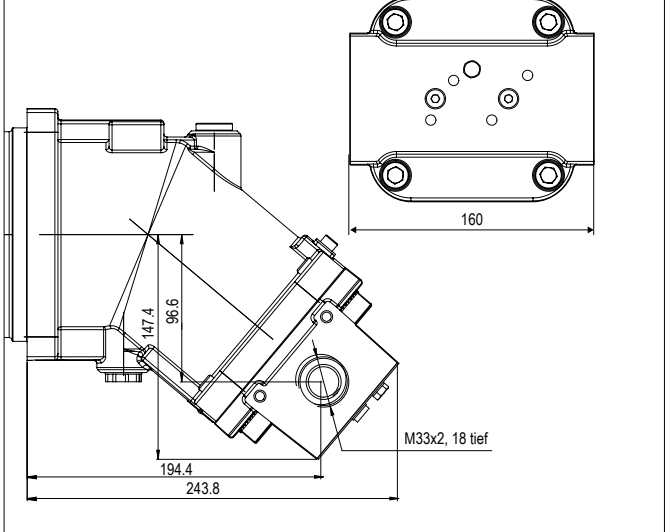

Maßangaben (mm) sind Anhaltswerte.

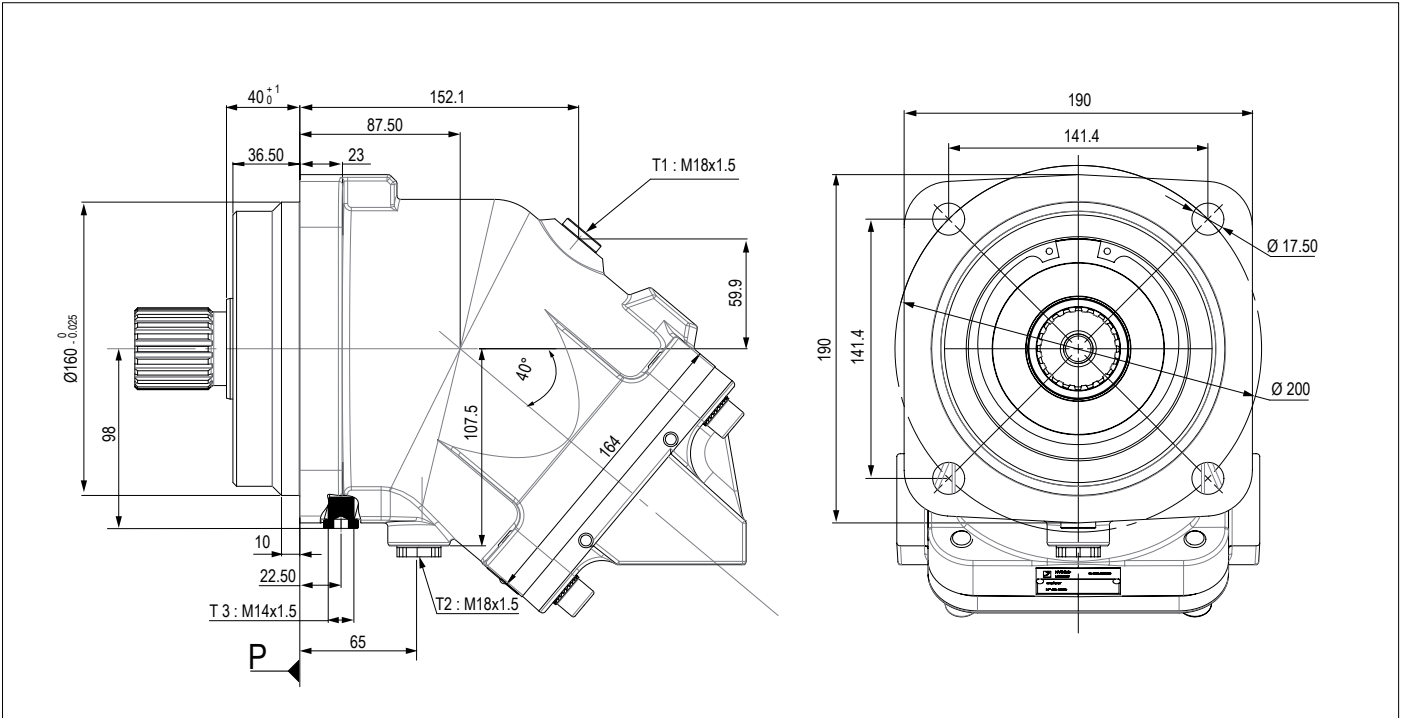

► Wellenausführung

W1 Zahnwelle DIN 5480
W 45 x 2 x 30 x 21 x 9 g

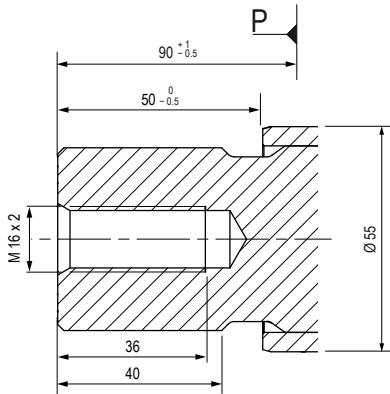

D1 Zylindrische Welle $\varnothing 45$ DIN 6885
AS 14 x 9 x 63

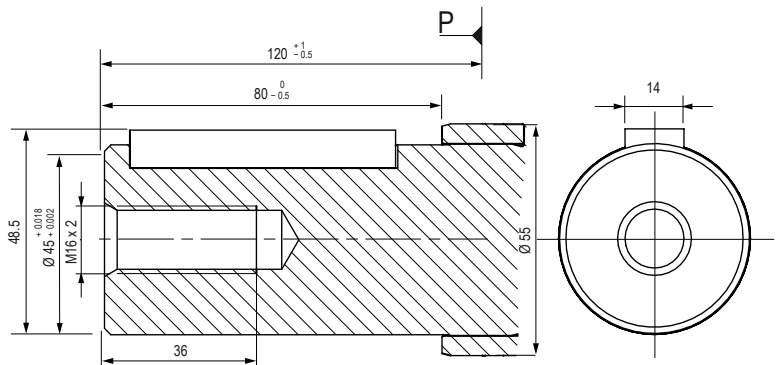

W2 Zahnwelle DIN 5480
W 40 x 2 x 30 x 18 x 9 g

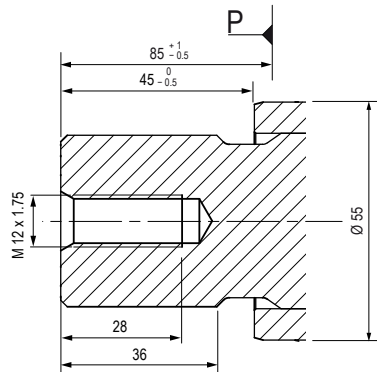

D2 Zylindrische Welle $\varnothing 40$ DIN 6885
AS 12 x 8 x 56

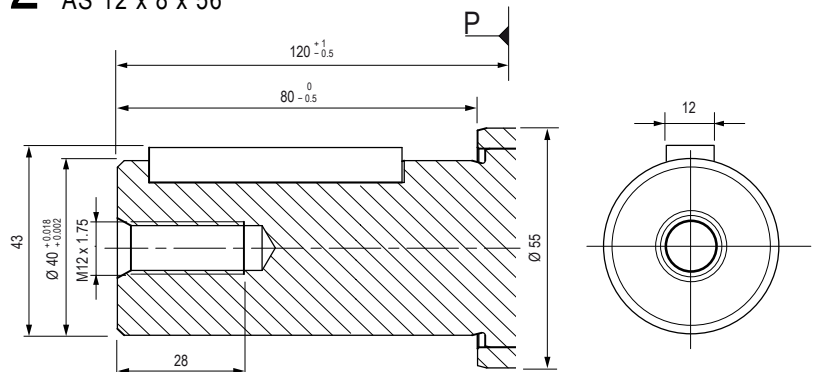

Max. Druck 5076 (350 bar) für M 125.

Nur für M 108 R.

M 108 R - 125

► Eintritt / Austritt

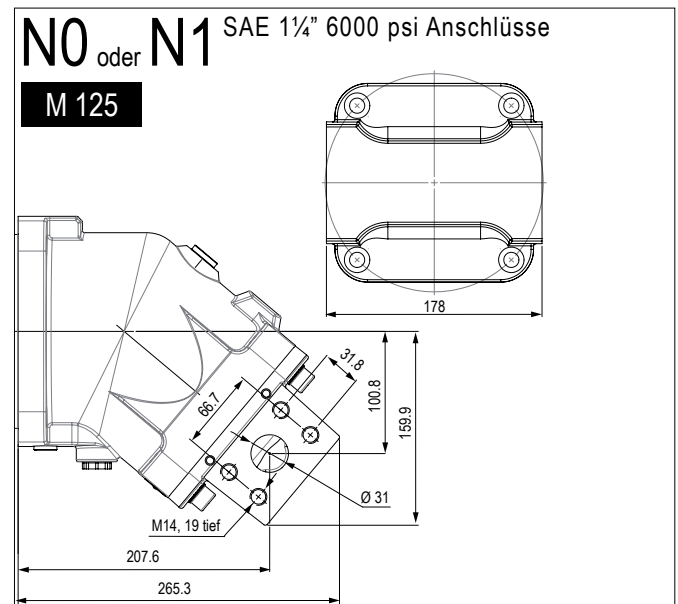
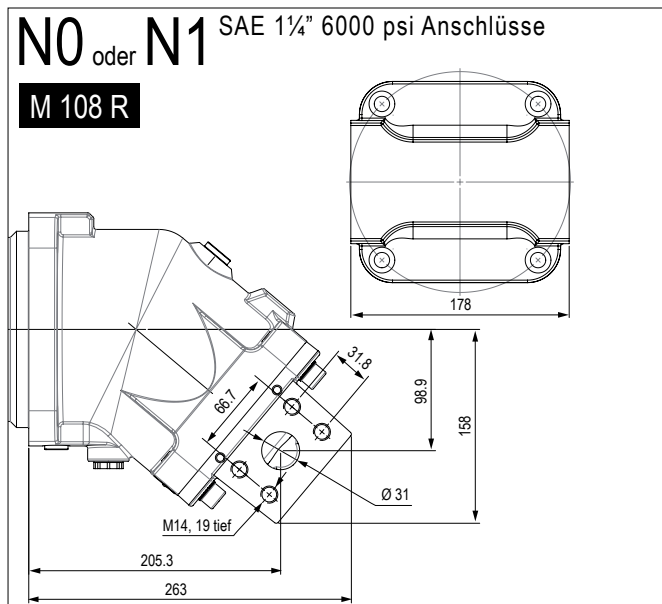
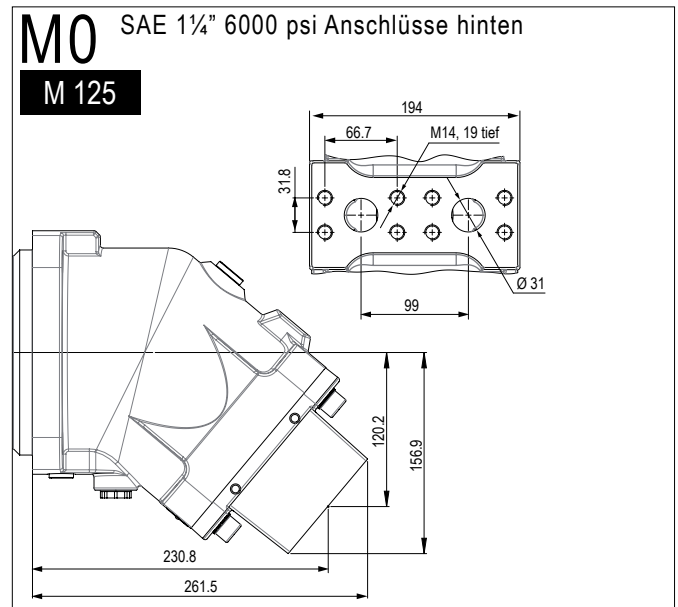
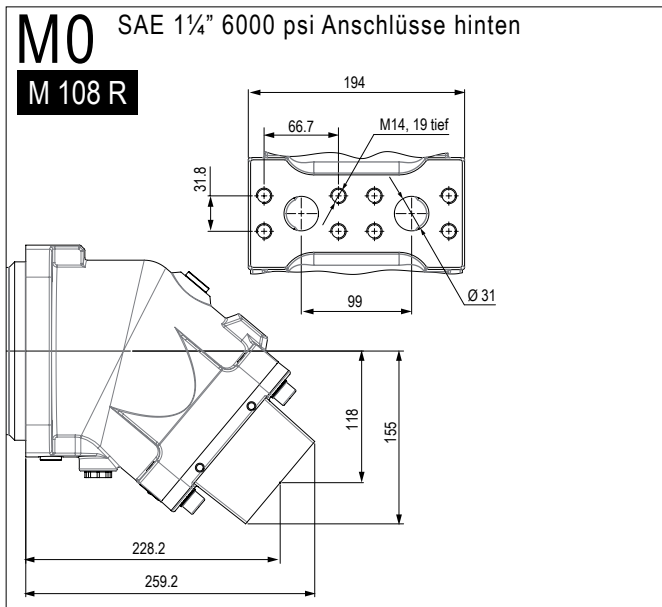
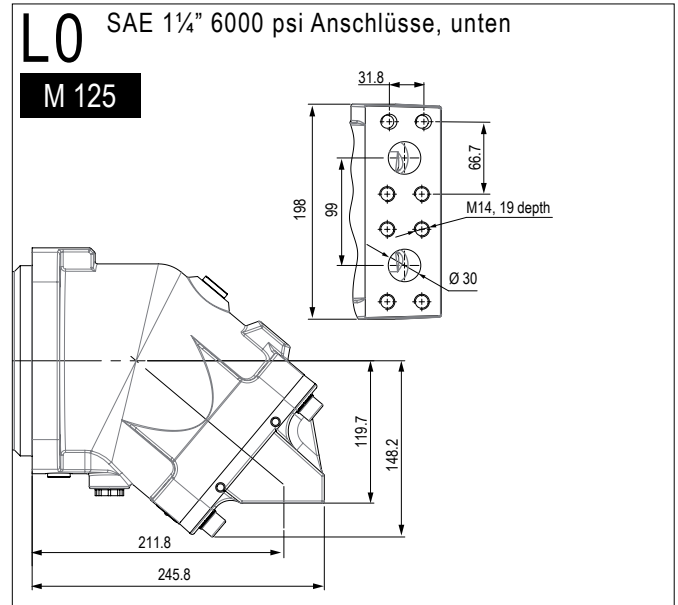
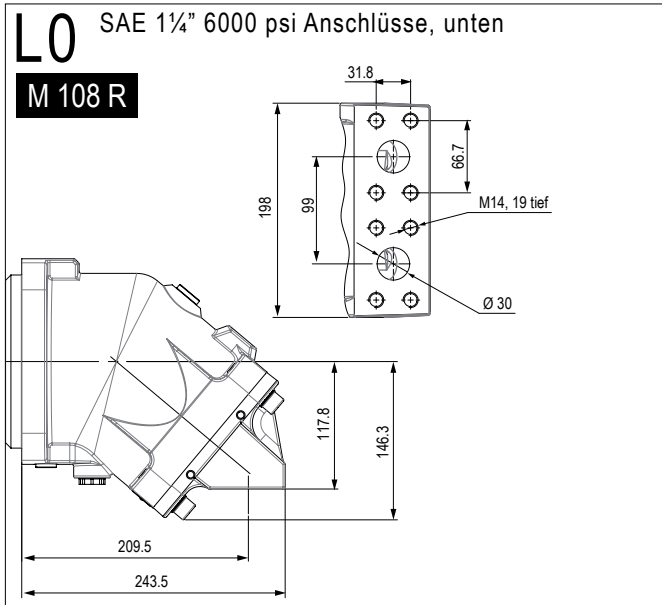

Maßangaben (mm) sind Anhaltswerte.

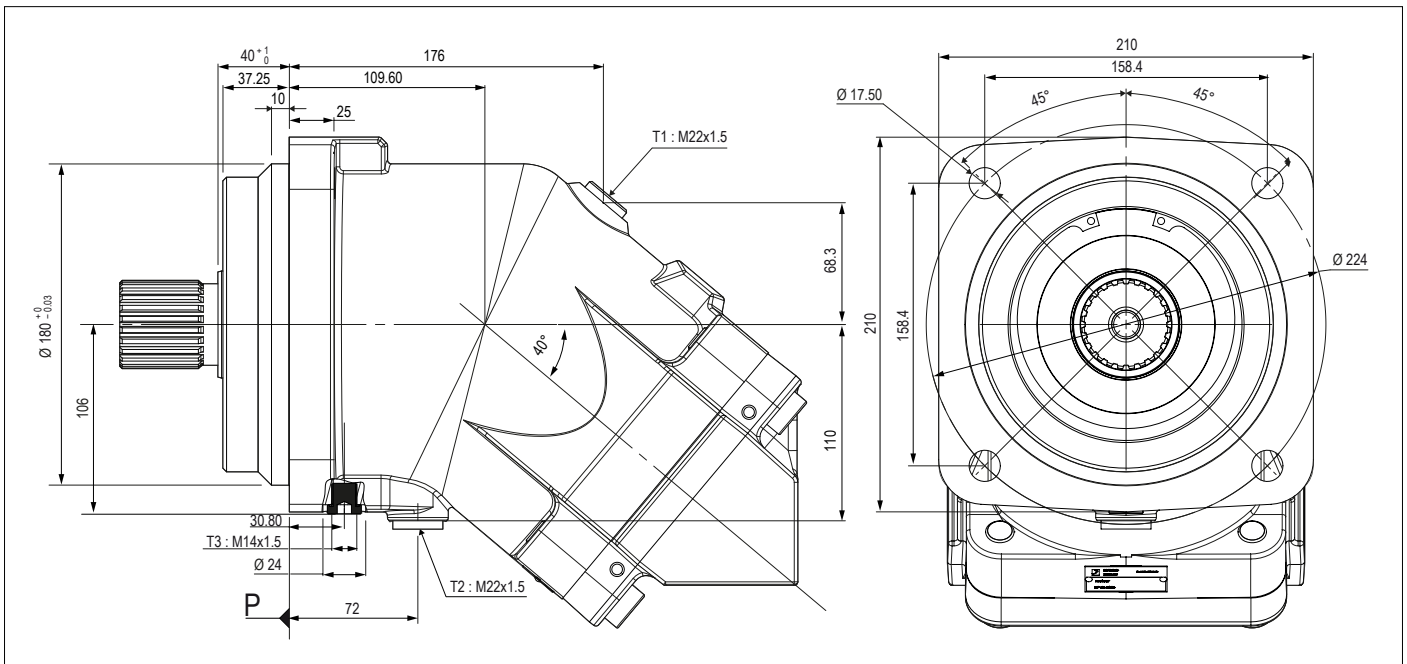

► Wellenausführung

W1 Zahnwelle DIN 5480
W 50 x 2 x 30 x 24 x 9 g

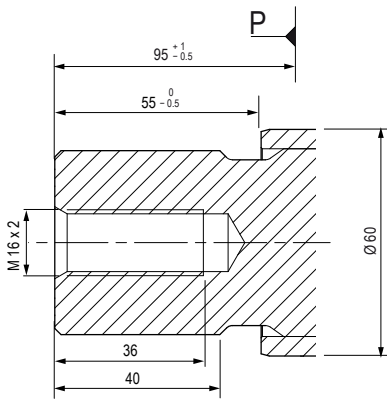

D1 Zylindrische Welle Ø 50 DIN 6885
AS 14 x 9 x 70

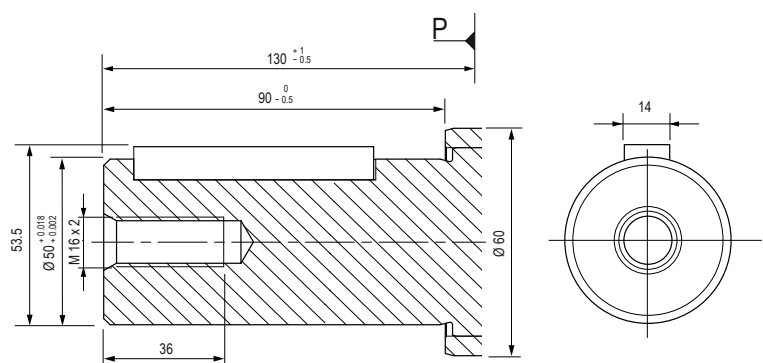

► **Eintritt/ Austritt**

