

Proportional Solenoids for Hydraulics

4

Product group

G RF ... B01

- According to VDE 0580
- Armature space pressure-tight up to 350 bar
- Also suitable for dry operation
- Magnetic-force vs stroke graph in the operating range horizontal to slightly decreasing
- To a great extent proportional relation between force and current
- Very small hysteresis through precise special bearing of the armature
- Short operating times
- Push type design
- Coil winding to insulation rating F
- Electrical connection and protection rating if mounted properly:
 - Spade connectors to DIN 46247
Protection rating to DIN VDE 0470/EN 60529 – IP 00
 - Plug connector type Z KB G to DIN 43650
cable gland (4 positions x 90°)
Protection rating to DIN VDE 0470/EN 60529 – IP 54
- Mounting with 4 screws
- Sealing between solenoid and valve through O-ring
- Special designs on request
- Application examples:
Particularly used as proportional actuator in pneumatic and hydraulic control chains and control circuits



Fig. 1: Type G RF Y 035 F20 B01

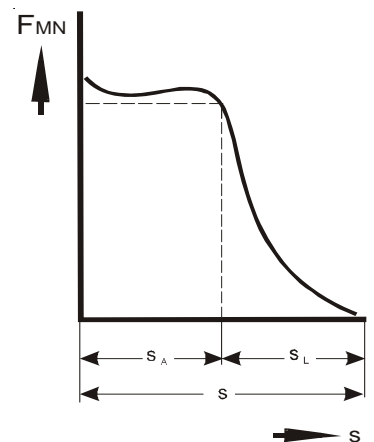

Fig. 2: Magnetic force vs stroke graph



Technical data

G R F Y ... F20 B01		035	045	060	
Duty rating ED		S1 (100 %)	S1 (100 %)	S1 (100 %)	
Reference temperature ϑ_{11}	(°C)	50	50	50	
Overall stroke s	(mm)	4 ±0,3	6 ±0,3	8 ±0,4	
Working stroke s_w	(mm)	2	3	4	
The indicated working stroke s_w is an approximate value. Owing to tolerances that occur, we recommend a stable operating range between	(mm)	0,5 - 1,5	0,5 - 2,5	0,5 - 3,5	
Idle stroke s_L	(mm)	2	3	4	
Rated magnetic force F_{MN}	(N)	50	65	145	
Rated magnetic force H_{FN} static	(%)	≈ 1,2	≈ 1,7	≈ 1,9	
Rated magnetic force H_{FN} dynamic	(%)	≈ 2	≈ 3	≈ 3,5	
Measured with measuring speed	(mm/min)	20	30	40	
Rated current hysteresis H_{IN}	(%)	< 2,5	< 2,5	< 4	
Rated linearity deviation L_N	(%)	2	2	2	
Armature weight m_A	(kg)	0,03	0,06	0,14	
Solenoid weight m_M	(kg)	0,43	0,75	1,75	
Rated resistance R_{20}	(Ω)	24,6	21	16,7	
Rated current I_N	(A)	0,68	0,81	1,11	
Maximum current I_G	(A)	0,68	0,81	1,11	
Linearity current I_L	(A)	0,14	0,15	0,15	
Response current I_A	(A)	0,05	0,02	0,05	
Rated power $P_N = I_N^2 \cdot R_{20}$	(W)	11,4	13,8	21	
Maximum power $P_G = I_G^2 \cdot R_W$	(W)	17,4	20,8	31	
The maximum power requires mounting on a hydraulic valve base plate with the following minimum dimensions.	hydraulic valve	(mm)	46 x 46 x 66	46 x 46 x 66	67 x 67 x 82
	base plate	(mm)	66 x 46 x 30	66 x 46 x 30	112 x 115 x 30
Linearity power $P_L = I_L^2 \cdot R_{20}$	(W)	0,48	0,47	0,38	
Response power $P_A = I_A^2 \cdot R_{20}$	(W)	0,06	0,0084	0,042	

dimensions

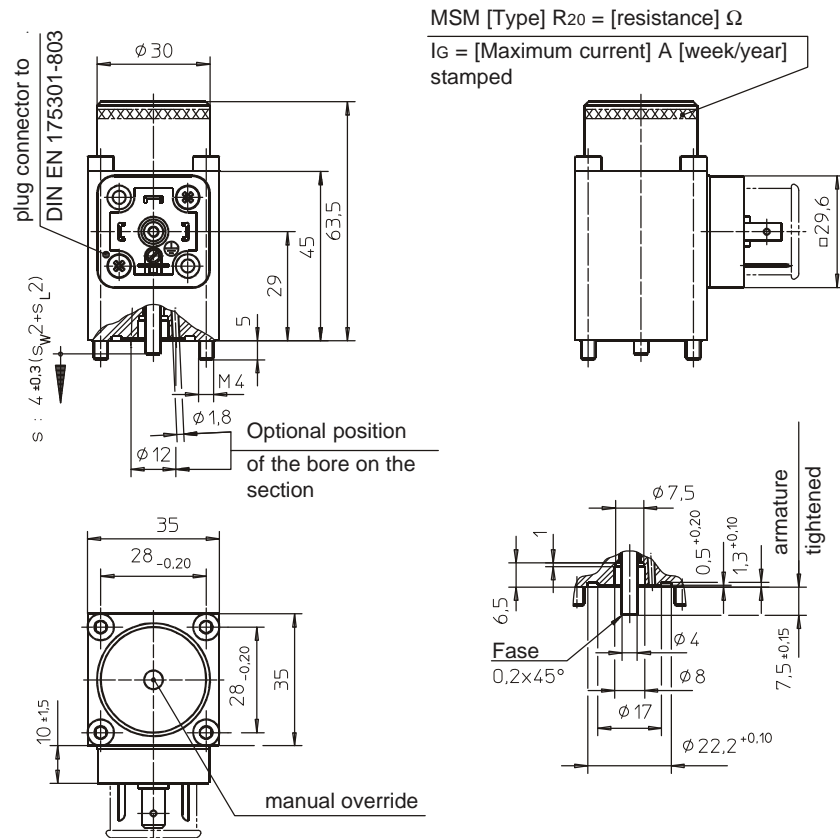

Fig. 12: Type G RF Y 035 F20 B01

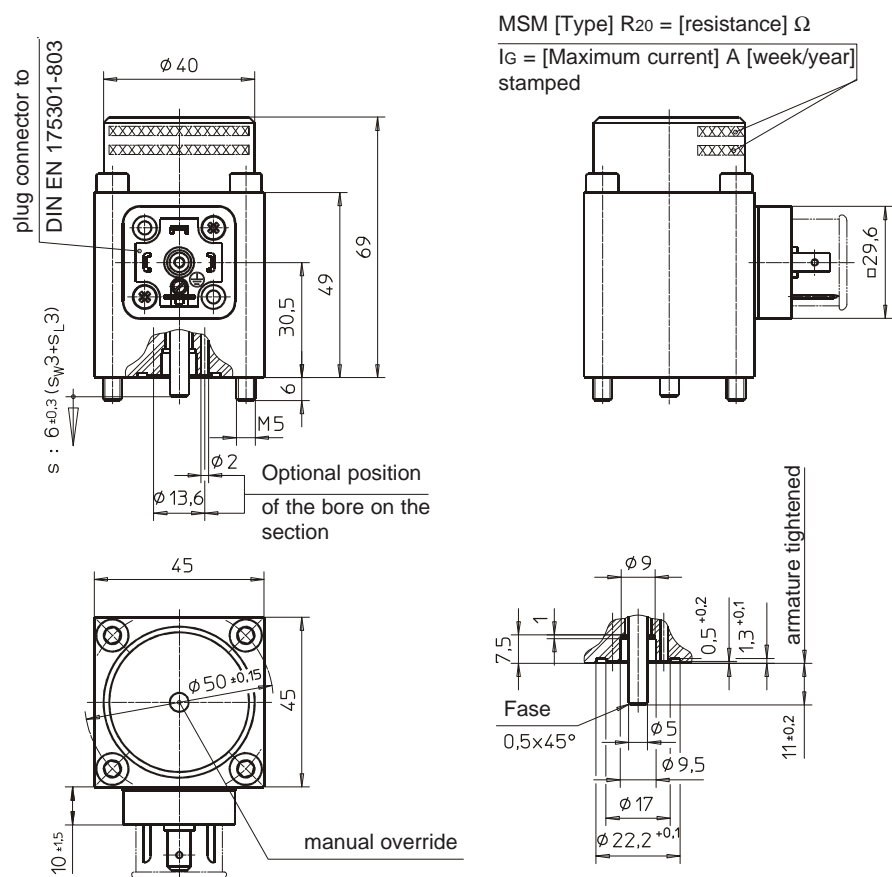

Fig. 13: Type G RF Y 045 F20 B01