

# Chelsea® 877 Series

Ten Bolt Constant Mesh P.T.O.



## Overview:

Power density is what you will find in the Chelsea 877 Series P.T.O. The new series provides you with a compact housing that helps eliminate clearance issues. Two assembly arrangements are offered that maximize your installation possibilities. High capacity bearings and superior gear designs provide you with torque ratings up to 670 Lbs. ft. for the ultimate performance. There is no need to de-rate the P.T.O. for continuous applications. The superior design of this P.T.O. provides you with all the power you will need. The 877 Series is a 10-Bolt mounting pattern that will fit on today's popular automatic transmissions. One hose is required for a simplified installation. Eight internal gear ratios provide you with a wide variety of speeds to meet your application requirements. The direct mount pump flange options are available with our Wet Spline design that provides you with increased P.T.O. and pump shaft life. Versatility, power, ease of maintenance and installation make the 877 Series the only choice for your vocational truck requirements.

- Fire and Rescue
- Waste
- Sewer
- Oil and Gas



## Product Features and Benefits:

### Contact Information:

Parker Hannifin Corporation  
**Chelsea Products Division**  
8225 Hacks Cross Road  
Olive Branch, MS 38654 USA

Phone: 1-888-PH4-TRUK  
(1-888-744-8785)

Fax: 1-662-895-1069  
chelseacustserv@parker.com

[www.parker.com/chelsea](http://www.parker.com/chelsea)

- Torque capacity up to 670 Lbs. ft. / 908 N.m.
- Compact housing height reduces clearance issues
- Nine speed ratios

- Nine output options
- Wet Spline pump flange extends P.T.O. and pump shaft life



ENGINEERING YOUR SUCCESS.

# 877 SERIES POWER TAKE-OFF SPECIFICATIONS AND TECHNICAL DATA

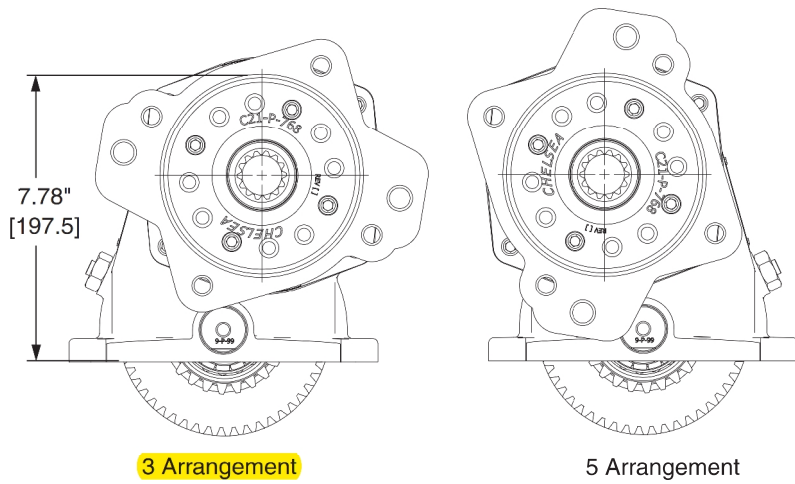
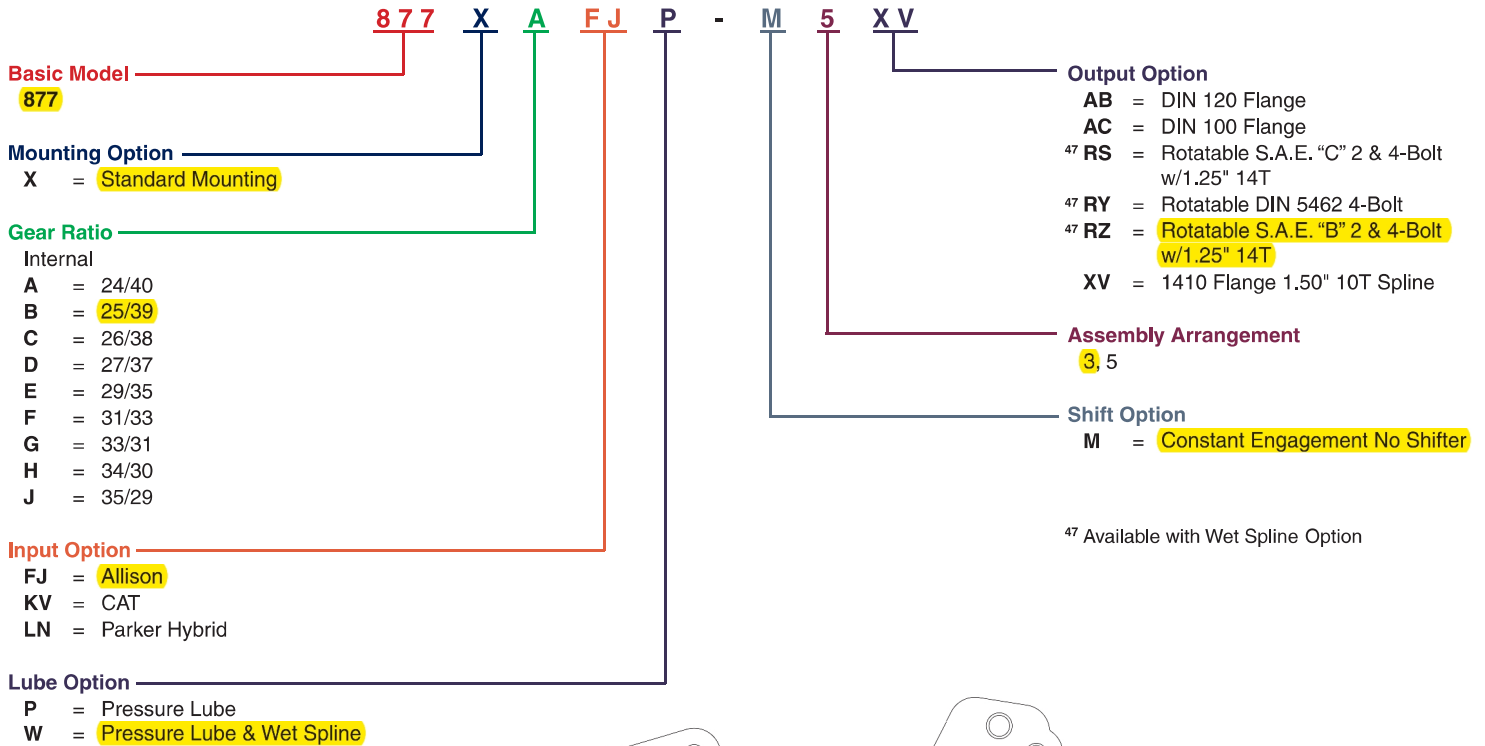

## Specifications Chart

	877*A	877*B	877*C	877*D	877*E	877*F	877*G	877*H	877*J
Standard Output Shaft Size				1-1/2" Spline w/1410 flange					
Intermittent & Continuous Torque Rating (Lbs. ft.)	670	630	590	550	485	430	380	355	335
Intermittent & Continuous Torque Rating (N.m.)	908	854	800	746	658	583	515	481	454
Horsepower Rating for Intermittent & Continuous Service									
At 500 R.P.M. of Output Shaft (HP)	64	60	56	52	46	41	36	34	32
At 1000 R.P.M. of Output Shaft (HP)	128	120	112	105	92	82	72	68	64
At 500 R.P.M. of Output Shaft (Kw)	48	45	42	39	35	31	27	25	24
At 1000 R.P.M. of Output Shaft (Kw)	95	90	84	78	69	61	54	51	48
Approximate Weight:				56 lbs. [25 kg]					

Check Application Pages for actual Torque Ratings