

### APPLICATION

The pressure relief valve, pilot operated, sandwich plate design type **UZPR 6...** is used to limit pressure in hydraulic systems.



### DESCRIPTION OF OPERATION

The pressure relief valve type **UZPR 6...** consists of the housing (1) in which the cartridge relief valves (2), pilot operated are installed. Due to appropriate combination

of connection lines in the housing (1) different versions of the valve according to hydraulic schemes shown on page 2 can be obtained.

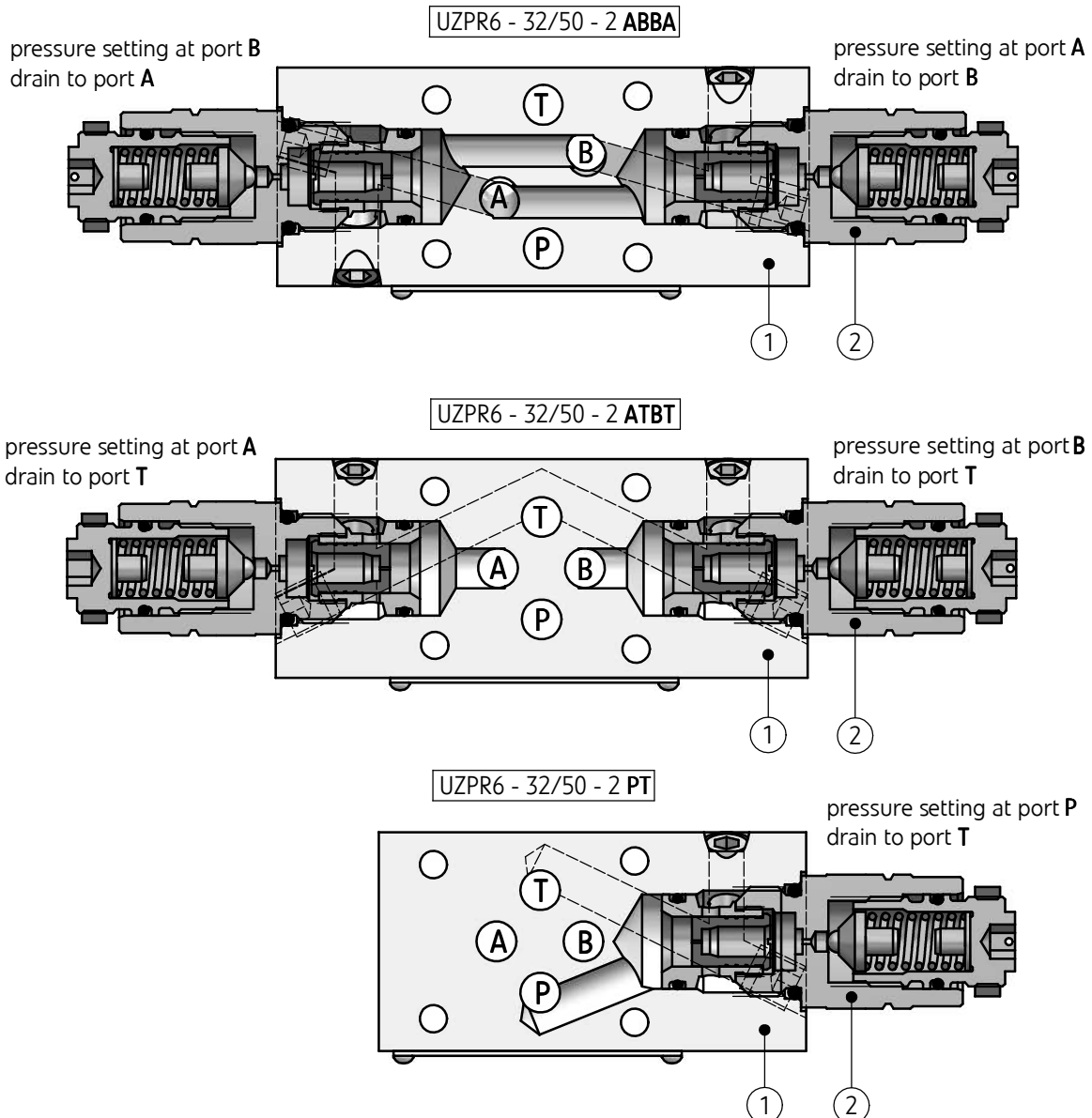

## TECHNICAL DATA

Hydraulic fluid	mineral oil	
Required filtration	up to 16 µm	
Recommended filtration	up to 10 µm	
Nominal fluid viscosity	37 mm <sup>2</sup> /s at temperature 55 °C	
Viscosity range	2,8 up to 380 mm <sup>2</sup> /s	
Fluid temperature range (in a tank)	recommended	40°C up to 55°C
	max	-20°C up to +70°C
Ambient temperature range	-20°C up to +70°C	
Maximum operating pressure	31,5 MPa	
Settable pressure ranges	5 MPa; 10 MPa; 20 MPa; 31,5 MPa	
Maximum set pressure	31,5 MPa	
Maximum flow	60 dm <sup>3</sup> / min	
Weight	1,2 or 1,5 kg (in relation to valve version)	

## SCHEMES

Hydraulic schemes of valves type **UZPR6...**

version **UZPR6...AT...**

outlet connection (receiver)

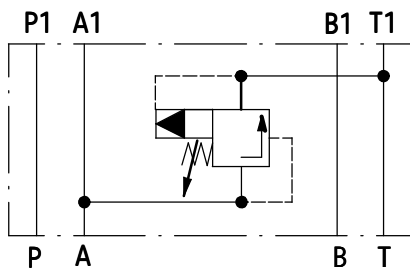

inlet connection (subplate)

version **UZPR6...ATBT...**

outlet connection (receiver)

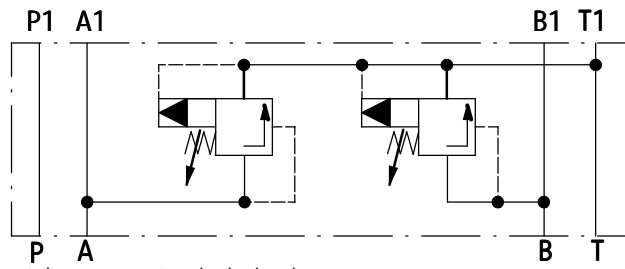

inlet connection (subplate)

version **UZPR6...BT...**

outlet connection (receiver)

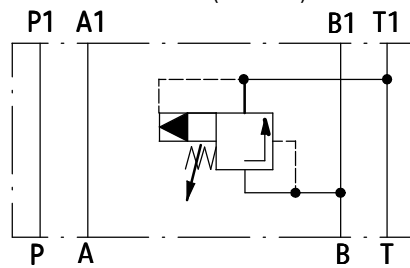

inlet connection (subplate)

version **UZPR6...ABBA...**

outlet connection (receiver)

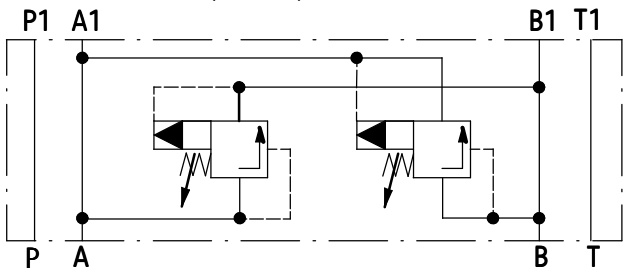

inlet connection (subplate)

version **UZPR6...PT...**

outlet connection (receiver)

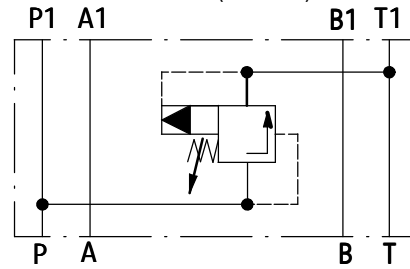

inlet connection (subplate)

# OVERALL AND CONNECTION DIMENSIONS

versions: **UZPR6...ABBA...** ...ATBT...

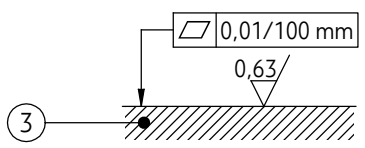
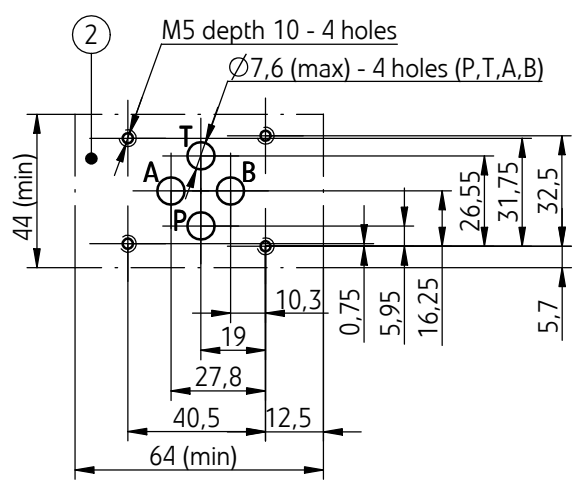
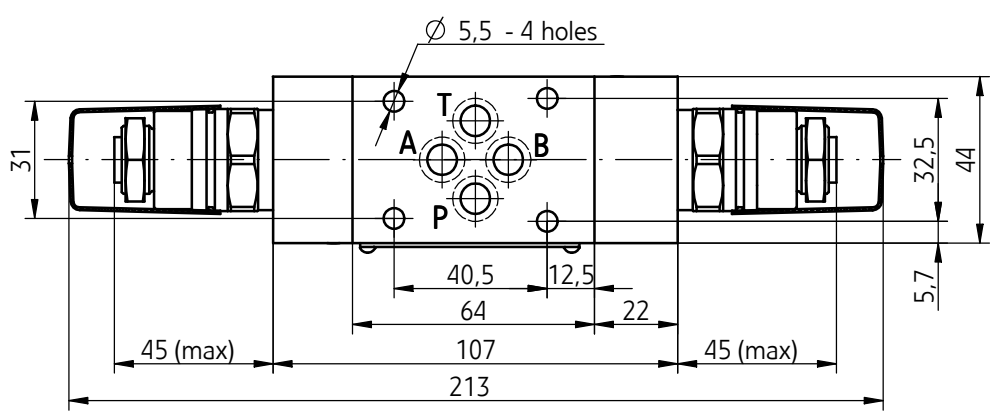
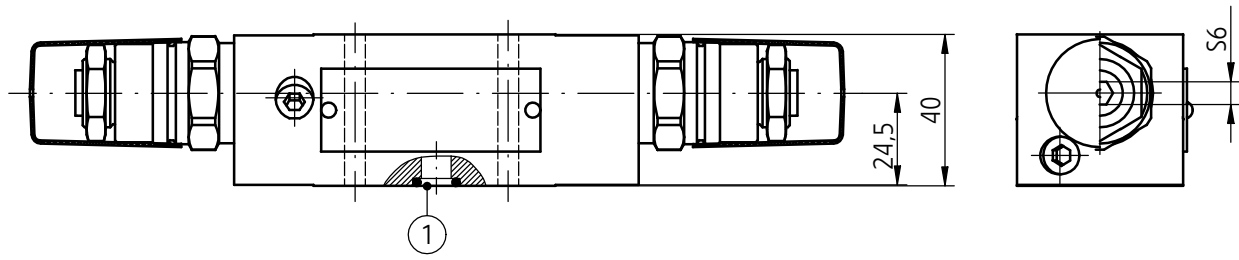

- 1 - Seal o-ring **9,2 x 1,8** - 4 pcs/kit (P, T, A, B)
  - 2 - Mounting holes configuration of a subplate in accordance with the standards listed below:
    - CETOP RP 121H - symbol **CETOP 4.2-4-03** (nominal size **CETOP 03**)
    - ISO 4401 - symbol **ISO 4401-03-02-0-94**
  - fixing screws **M5 x L\*** - **10.9** - 4 pcs/kit in accordance with **PN - EN ISO 4762** tightening torque **Md = 9 Nm**
  - 3 - Required surface finish of a subplate
- NOTE:**  
 (\*) - Required length of the screws L is related to type and the number of hydraulic components sandwich fitted

## OVERALL AND CONNECTION DIMENSIONS

versions: UZPR6...AT...; ...BT...; ...PT...

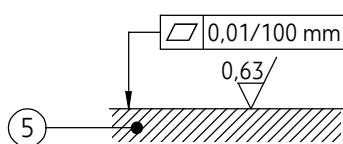
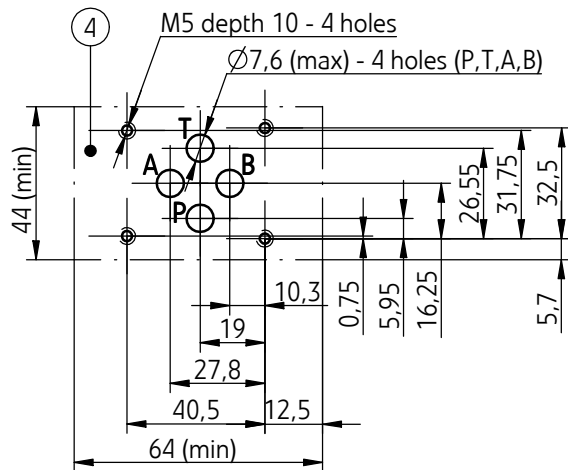
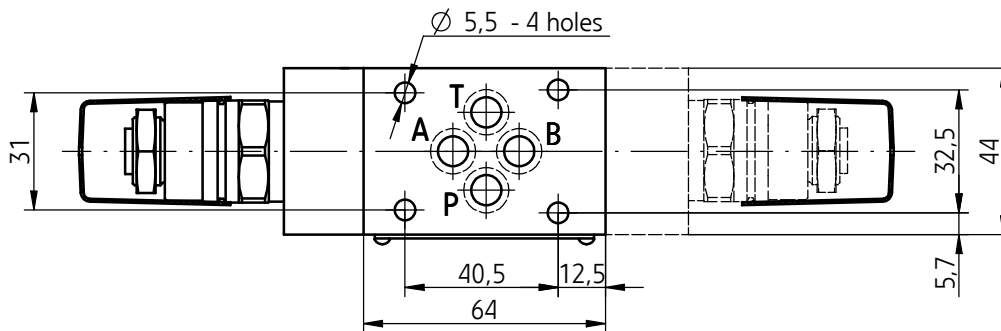
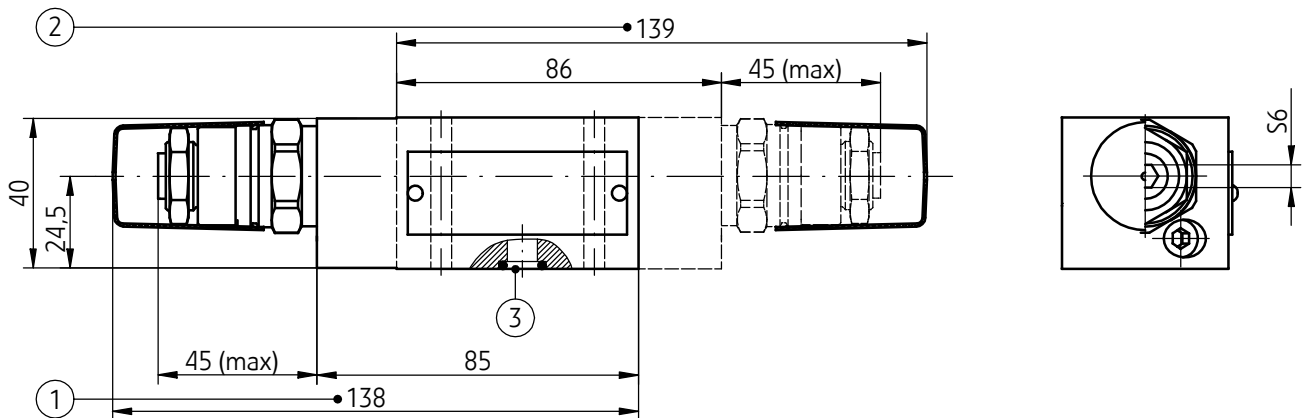

- 1 - Overall dimension for the valve version UZPR6...AT...
  - 2 - Overall dimension for the valve versions: UZPR6...PT... ; UZPR6...BT...
  - 3 - Seal o-ring **9,2 x 1,8** - 4 pcs/kit (P, T, A, B)
  - 4 - Mounting holes configuration of a subplate in accordance with the standards listed below:
    - CETOP RP 121H - symbol **CETOP 4.2-4-03** (nominal size **CETOP 03**)
    - ISO 4401 - symbol **ISO 4401-03-02-0-94**
- fixing screws **M5 x L\*** - **10.9** - 4 pcs/kit in accordance with **PN - EN ISO 4762**  
tightening torque **Md = 9 Nm**
- 5 - Required surface finish of a subplate

**NOTE:**

(\*) - Required length of the screws L is related to type and the number of hydraulic components sandwich fitted

## HOW TO ORDER

<b>UZPR</b>	<b>6</b> +	/	+				<b>*</b>
-------------	------------	---	---	--	--	--	----------

<b>Nominal size (NS)</b> <b>NS6</b> = <b>6</b>							
<b>Series number</b> (30-39) - connection and installation dimensions unchanged = 3X <b>series 32</b> = <b>32</b>							
<b>Settable pressure range</b> up to <b>5 MPa</b> = <b>50</b> up to <b>10 MPa</b> = <b>100</b> up to <b>20 MPa</b> = <b>200</b> up to <b>31,5 MPa</b> = <b>315</b>							
<b>Adjustment element</b> <b>set screw with internal hexagon</b> = <b>2</b>							
<b>Relief function for flow direction</b> (hydraulic schemes according to page 2) from A to T = AT from B to T = BT from <b>P</b> to <b>T</b> = <b>PT</b> from A to T and from B to T = ATBT from A to B and from B to A = <b>ABBA</b>							
<b>Sealing</b> <b>NBR</b> (for fluids on mineral oil base) = <b>no code</b> <b>FKM</b> (for fluids on phosphate ester base) = <b>V</b>							
Further requirements in dear text (to be agreed with the manufacturer)							

### NOTES:

The pressure relief valve should be ordered according to the above coding.  
**The symbols in bold are the preferred versions available in short delivery time.**  
 Coding example: UZPR6 - 32/315 - 2 PT

## PERFORMANCE CURVES

measured at viscosity  $\nu = 41 \text{ mm}^2/\text{s}$  and temperature  $t = 50^\circ\text{C}$

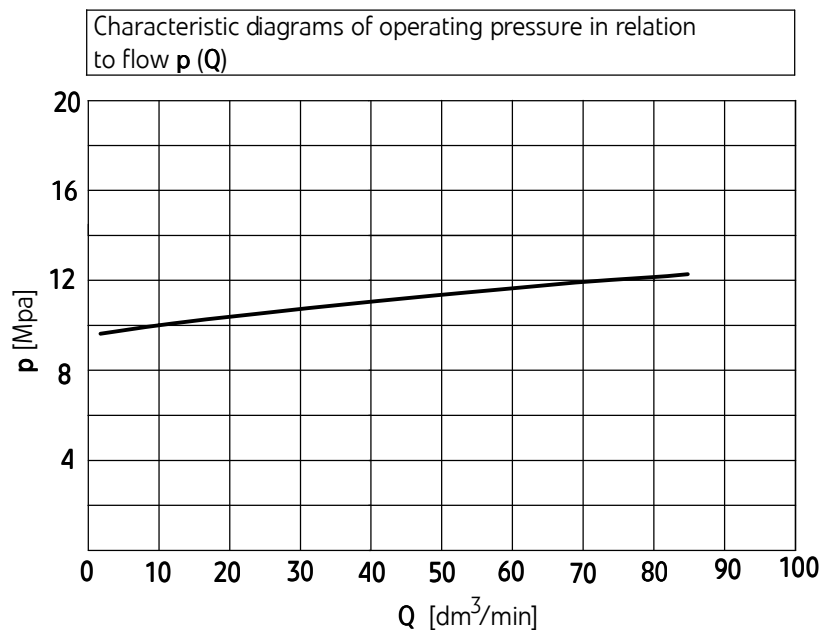

## SUBPLATES AND FIXING SCREWS

Subplates must be ordered according to catalogue sheet **WK 496 480**. Subplate symbols:

- G 341/01** - threaded connections **G 1/4**
- G 342/01 - threaded connections G 3/8
- G 502/01 - threaded connections G 1/2
- G 341/02 - threaded connections M14 x 1,5
- G 342/02 - threaded connections M16 x 1,5

Subplates and screws fixing the relief valve **M5 x L\* - 10,9** - 4 pcs/kit in accordance with **PN - EN ISO 4762** must be ordered separately. Tightening torque **Md = 9 Nm**

### NOTES:

(\*) - Required length of the screws **L** is related to type and the number of hydraulic components sandwich fitted.

The subplate symbol in bold is the preferred version available in short delivery time.

PONAR Wadowice S.A.  
ul. Wojska Polskiego 29  
34-100 Wadowice  
tel. +48 33 488 21 00  
fax. +48 33 488 21 03  
[www.ponar-wadowice.pl](http://www.ponar-wadowice.pl)

