

Diese Zeichnung darf weder ganz noch teilweise ohne unsere ausdrückliche Genehmigung kopiert oder auf andere Weise vervielfältigt werden. Zuwiderhandlungen werden gerichtlich verfolgt.
 Alla rättigheter förbehålls. All rights reserved. Alle Rechte vorbehalten.

Denna handling får ej utan vårt medgivande delges annan, kopieras eller eljest obehörigen användas. Överräkelse härvid beivras med stöd av gällande lag. This document must not be copied, either completely or in part, without permission. Any infringement will have legal consequences.

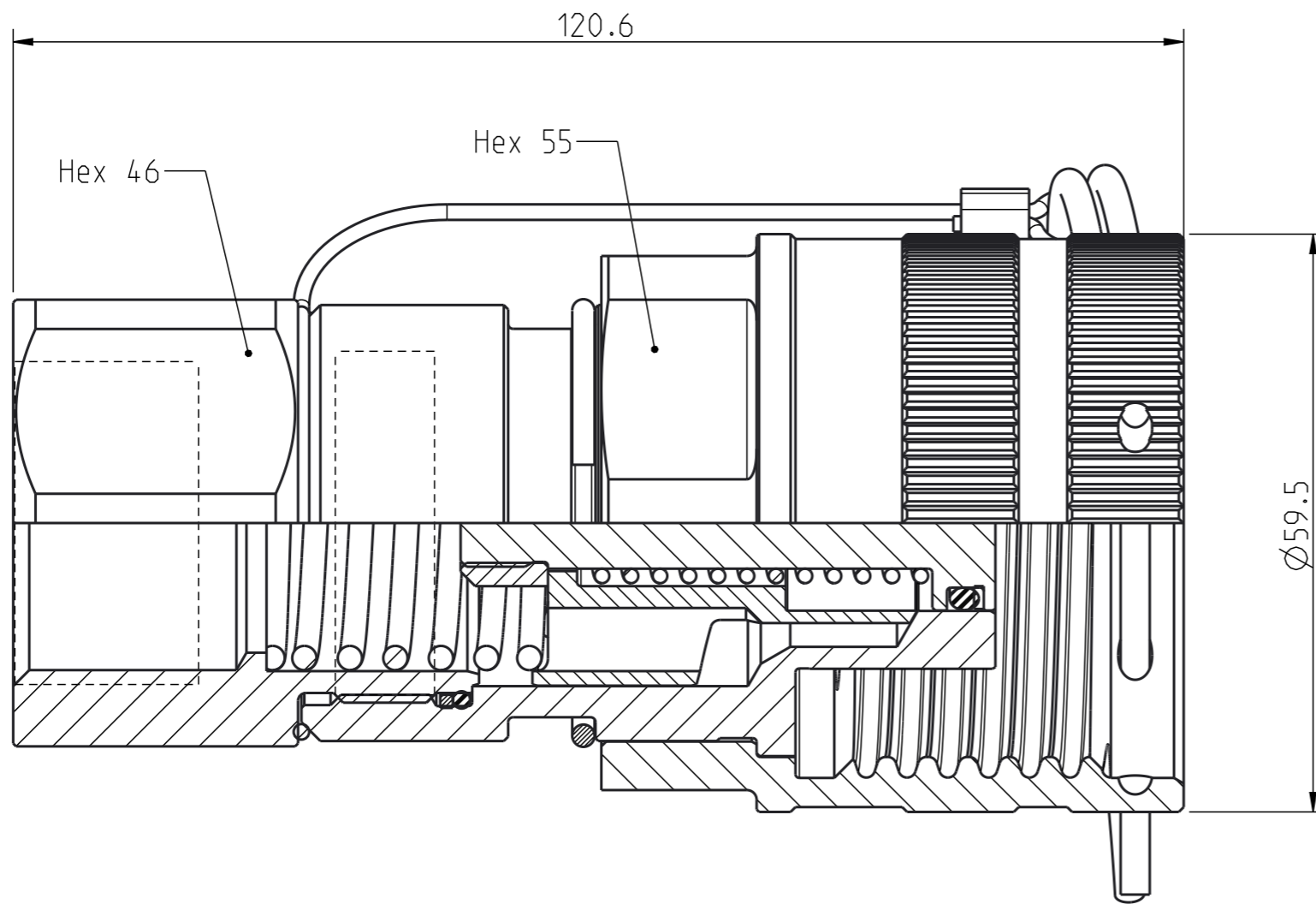

16	1	Wire coil	Stainless steel
15	2	Wire clamp	Aluminium
14	1	Wire	Steel/ PA
13	1	Valve sleeve	Steel
12	1	Valve	Steel, Zi-Ni 9 transp
11	1	Sprint	Stainless steel
10	1	Spring	Stainless steel
9	1	Spring	Stainless steel
8	1	O-ring	NBR
7	1	O-ring	NBR
6	1	Nut	Steel
5	1	Nipple Body	Harden. Steel, Zi-Ni 9 transp
4	1	Locking Sleeve	Steel Zi-Ni 9 transp
3	1	Back-up	PTSM
2	1	Back up ring	PTFE
1	1	Back part	Steel, Zn-Ni 9 transp
Detalj Item	Antal Quant.	Benämning Description	Material Material

Product no: 10_607_6203		
Max working pressure:	400 bar connected	330 bar disconnected
Min burst pressure:	1600 bar connected	990 bar disconnected
Sealing material:	NBR	
Temperatur range:	-30°C - +100 °C	
Nominal flow diameter, DN:	mm	
Connection	G 1" fem	
Connection stroke:	mm	

CEJN	Skala Scale	3:2	Ritad Drawn	CABMBA	Kontr. Checked	JoEr	Godk. Appr.	PMB	Äm nr. Alt. no.	10586	Dat. Date	13-10-15
	Assembly drawing							Ritning nr./Drawing No.		50_607_6203	Utg./Issue	