

d ZL007-DS

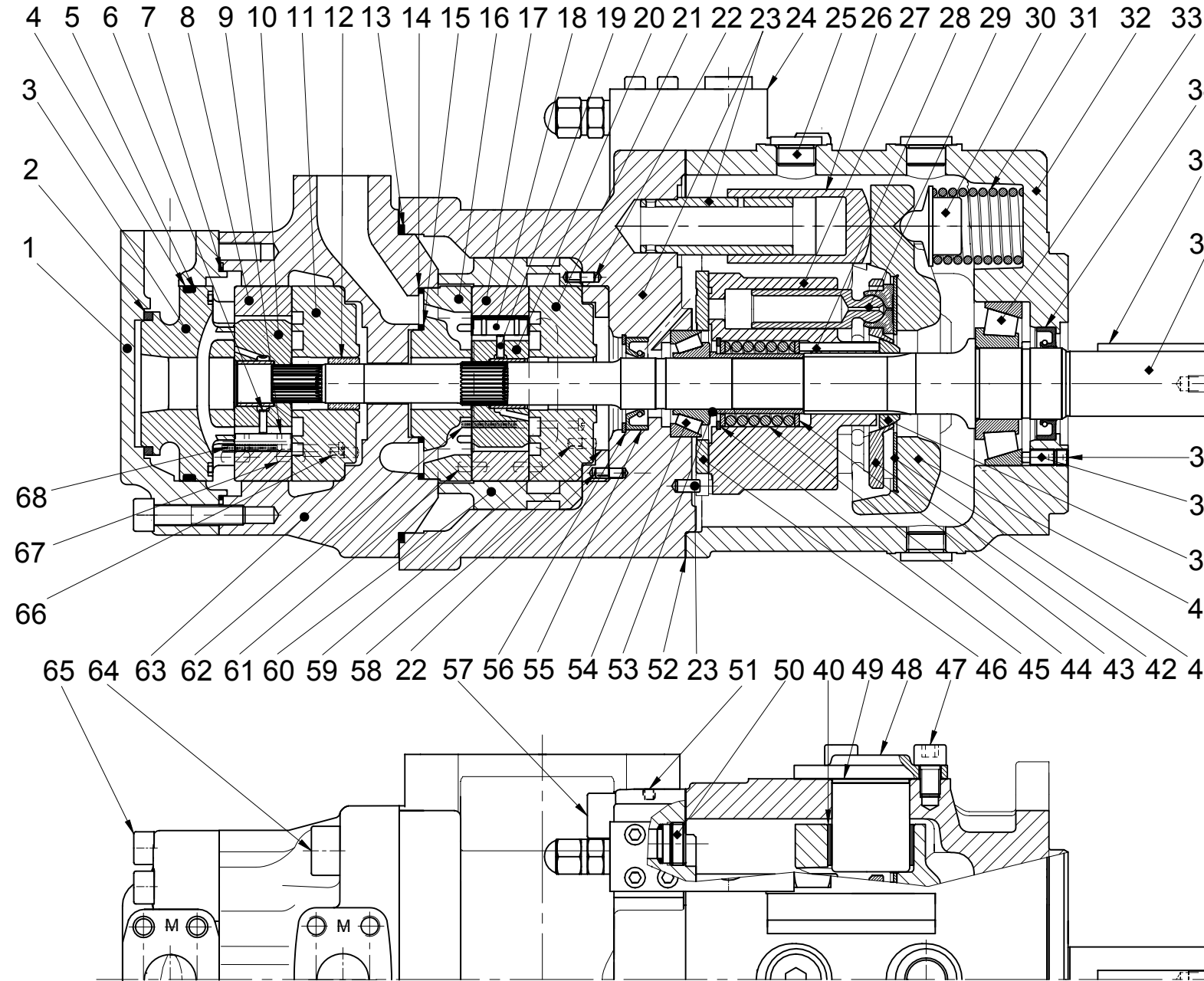

024-77407-0		T6H29BB B15 B15 1R1B 4F0M0 40		
item	kit	code number	qty	description
1		034-71327-0	1	CAP T6DC END 1" MET
2	AC	691-10229-0	1	ORING ID 59.92X3.40 S1 90 SH
3	A	034-66923-0	1	PLATE T7B PRESS BI-ROT
4	AC	691-10238-0	1	ORING ID 88.49X3.40 S1 90 SH
5	AC	618-15016-0	1	RING BACKUP C SIZE BRP2107238
6	A	034-66991-0	12	PIN T67BB VANE HOLDOUT
7	AC	671-10156-0	1	ORING ID 107.62X2.51 S1 70 SH
8	A	034-67034-0	1	CAM T7B 015
9	A	034-66917-0	12	VANE T7B
10	A	S24-49820-0	1	ROTOR T7B ASSY
11	AD	034-66922-0	1	PLATE T67CB REAR "B" BI-ROT
12	AD	034-59412-0	1	BUSH BEARG 25.4 X19.18X15
13	BC	691-10256-0	1	ORING ID 145.64X3.40 S1 90 SH
14	BC	691-10153-0	1	ORING ID 88.57X2.51 S1 90 SH
15	BC	691-10137-0	1	ORING ID 52.07X2.51 S1 90 SH
16	B	034-67060-0	1	PLATE T67DBB PRESS BI-ROT
17	B	034-67034-0	1	CAM T7B 015
18	B	034-66917-0	12	VANE T7B
19	B	034-66991-0	12	PIN T67BB VANE HOLDOUT
20	B	S24-51722-0	1	ROTOR T67BB ASSY "B"
21	BE	034-66922-0	1	PLATE T67CB REAR "B" BI-ROT
22		323-82010-0	2	PIN GROOV 4.76X13
23		S24-77459-0	1	BLOCK T6H29BB CW MET ASS.
24		S24-68692-0	1	CONT'L PV TYPE F BSP ASS
25		447-01008-2	3	PLUG STEEL 1/2" BSP W/S1
26		034-67333-0	1	PLNGR T6H29 CTL HANGER
27	F	039-54039-0	1	BARRL PV29
28	F	324-30020-0	3	PIN DOWEL 039-57828-A
29	F	S29-01170-0	9	PISTON & SHOE ASSY PV29
30		039-54104-0	1	SEAT PV29 SPRING HANGER
31		039-54099-0	1	SPRNG PV29 HANGER
32		034-67319-0	1	HOUSG T6H29 BSP TAP BRG
33	G	230-90028-3	1	BEARG ROLER 35x80x22.75 TAPR
34	C	620-82106-0	1	SEAL LIP S1 35 X 55 X11 HP
35	G	034-66980-0	1	KEY SQUARE 7.94X60
36	G	034-67628-0	1	SHAFT T6H29BB KEYED 1 T. B.
37		311-60028-3	3	SCREW SS FLAT PT M8x8 DIN 913
38		311-60030-3	3	SCREW SS M 8x12 FL PT D913 45H
39	F	039-54258-0	1	BALL PV29 HOLDDOWN PISTONS
40		S24-68967-0	1	HANGR T6H29 B MOD ASS
41	F	039-91355-0	1	PLATE PV29 WEAR
42	F	039-54084-0	1	PLATE PV29 GUIDE PISTONS
43	F	039-54139-0	2	WASHR PV29 BARREL
44	F	039-54094-0	1	SPRNG PV29 BARREL
45	F	356-65118-0	1	RING RETAIN INT BORE 42 PV29
46	F	034-67329-0	1	PLATE T6H29 PORT CW T. B.
47		361-11154-8	6	SCREW SHC M10X 15 D912 G12.9
48		034-66982-0	2	TRUNN T6H29
49	C	039-54133-0	2	GASKT PV20 TRUNNION
50		513-10010-3	1	VALVE CHECK "HAWK" RB3 1/2"
51		431-90100-0	1	PLUG HEX SOC 1/16NPTF
52	C	039-54129-0	1	GASKT PV29 BLOCK
53	G	034-67315-0	1	SPACR T6H29 TAPER BEARING
54	G	230-90029-3	1	BEARG ROLER 25x52x19.25 TAPR
55	C	620-00020-3	1	SEAL LIP S1 25 X 45 X10
56		356-65107-0	1	RING RETAIN INT BORE 45
57		361-13274-3	4	SCREW SHC M14X 55 D912 G12.9
58		034-67632-0	1	PLATE T6H29BB SUPPORT CART.
59	E	323-82010-0	1	PIN GROOV 4.76X13
60		034-67631-0	1	ADAPT T6H29BB CENTER CART.
61	B	324-21208-0	2	PIN DOWEL 4.76X12.7
62	B	317-06266-0	2	SCREW FILL 6 32NC 2 1/4 NYL
63		034-67630-0	1	BLOCK T6H29BB PORT CENTR
64		361-14284-3	4	SCREW SHC M16X 60 D912 G12.9
65		361-11264-3	7	SCREW SHC M10X 50 D912 G12.9
66	A	323-82010-0	1	PIN GROOV 4.76X13
67	A	324-21208-0	2	PIN DOWEL 4.76X12.7
68	A	317-06266-0	2	SCREW FILL 6 32NC 2 1/4 NYL

REPAIR KIT

A		S24-59011-0	1	CARTRIDGE ASS B15 CW (P3)
B		S24-59725-0	1	CARTRIDGE ASS B15 CW (P2)
C		S24-77460-0	1	SEAL KIT S1
D		S24-50642-0	1	PORT PLATE REAR ASS (P3)
E		S24-59751-0	1	PORT PLATE REAR ASS (P2)
F		S24-69588-0	1	ROTATING GROUP CW (P1)
G		S24-77435-0	1	SHAFT & BEARING ASS CODE 1

ATTENTION !
 CE PLAN Y COMPRIS LES INFORMATIONS SONT LA PROPRIETE DE DENISON HYDRAULICS VIERZON-FRANCE. IL EST LIVRE POUR LA SEULE UTILISATION DE : -

IL NE PEUT ETRE DELIVRE OU REPRODUIT POUR UNE LIBRE CIRCULATION SANS L'ACCORD ECRIT DU DEPARTEMENT ENGINEERING DE VIERZON.
 PAR : - LE : -

NON DEFINI SUR DESSIN
 1-Dimensions et tolérances suivant USA SI Y34-5-1966 ou APPROX NF E 04-952;
 2-Etat de surface 12.5µinch (Ra 3.2)
 3-Tolérances pour surfaces usinées :
 - Casage d'angles 0.25 - rayon intérieur 0.760/0.127
 1 décimale ±0.25 - 2 décimales ±0.13
 4-Angles α 1/2°;
 5-Tolérances perçage de trous suivant n°41.6
 6-Tolérances de fonderie suivant SA-9347
 7-Autres: voir notes

MATIERE :

DESSINE EN CAO

ET. -
 DES. L.M.
 VER. -
 DATE : 28-Jan-02
 ECH. : 1
 POIDS ESTIME 79 Kg
 PLAN DE 1/1

DENISON Hydraulics VIERZON FRANCE

TRIPLE HYBRID PUMP T6H29BB

SD-70072