

Alle r tigheter f rbeh lls.  
All rights reserved.  
Alle rechte vorbehalten.

Diese Zeichnung darf weder ganz noch teilweise ohne unsere ausdr ckliche Genehmigung kopiert oder auf andere Weise vervielf tigt werden. Werden. Zuwiderhandlungen werden gerichtlich verfolgt.

Denna handling f r ej utan v rt medgivande delges annan. kopieras eller eljest obeh rigen anv ndas.  verr ttelse h rvid beivras med st d av g llande lag. This document must not be copied, either completely or in part, without permission. Any infringement will have legal consequences.

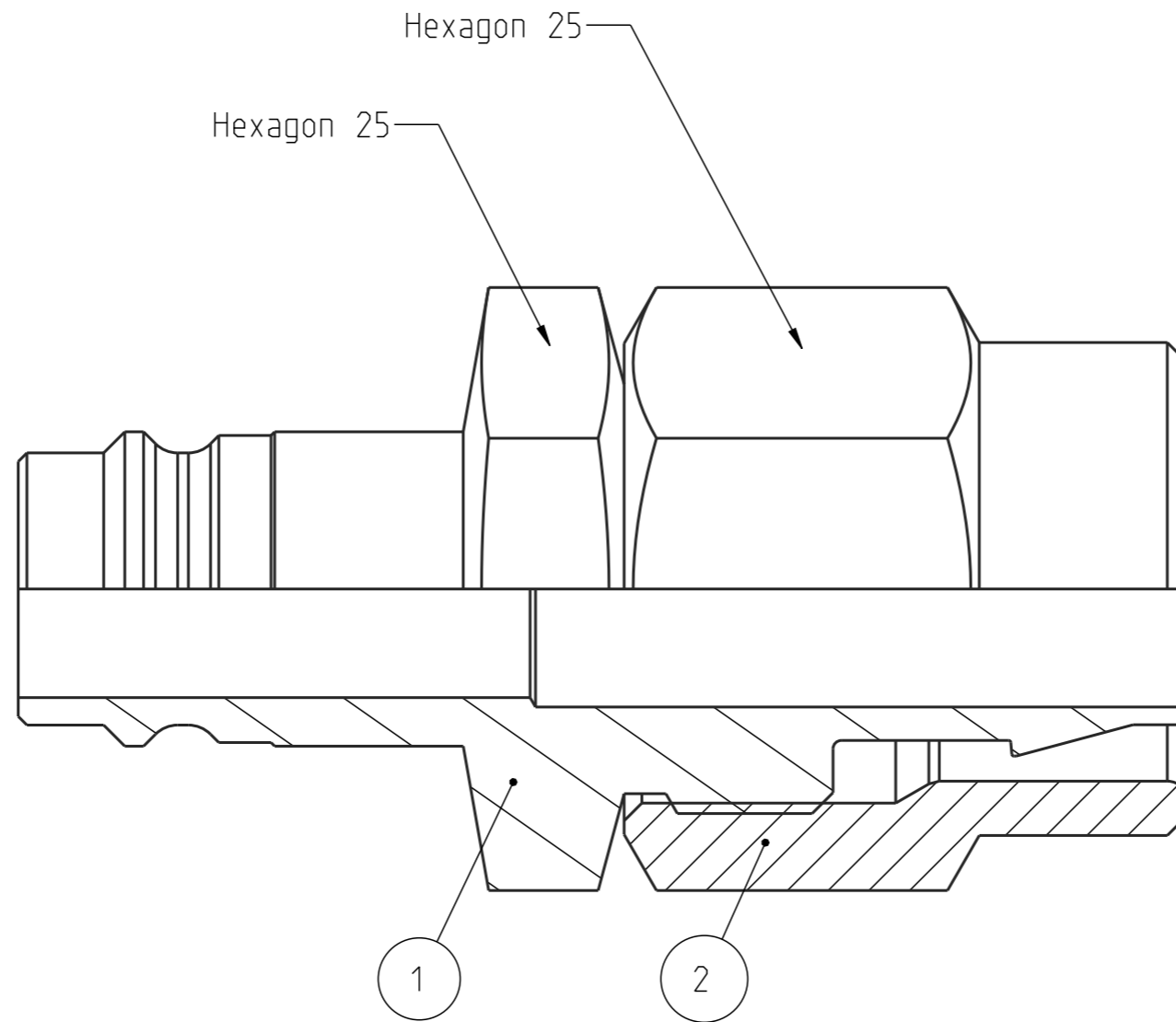
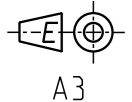

1:1

Product no: 10\_410\_5068

Max working pressure:	-	bar connected
		bar disconnected
Min burst pressure:	-	bar connected
		bar disconnected
Sealing material:	-	
Temperatur range:	-20°C - +100 °C	
Nominal flow diameter, DN:	10.4	mm
Connection	Stream-line	13x18
Connection stroke:	-	mm

2	1	Swivel nut	Steel, Zn 8 Silver
1	1	Nipple body	Steel hard., Zn 8 Silver
Detalj Item	Antal Quant.	Ben�mning Description	Material Material

	Skala Scale	3:1	Ritad Drawn	CABJ00L	Kontr. Checked	LHe	Godk. Appr.	OG	Alt. nr. ALT. no.	Dat. Date	130326
	Assembly drawing							Ritning nr./Drawing No.		50_410_5068	Utg./Issue