

Model No. **T7BB or T7BBS - B10 - B10 - 1 R 00 - A 1 - M1 - ..**

T7BB series - 100 A2 HW

ISO 2 bolts 3019-2 mounting flange

T7BBS series - SAE B 2 bolts

J744 mounting flange

Displacement P1 & P2

Volumetric displacement (ml/rev.)

B02 = 5,8 B09 = 28,0

B03 = 9,8 B10 = 31,8

B04 = 12,8 B11 = 35,0

B05 = 15,9 B12 = 41,0

B06 = 19,8 B14 = 45,0

B07 = 22,5 B15 = 50,0

B08 = 24,9

Type of shaft T7BB - T7BBS

5 = keyed (ISO R775)

Type of shaft T7BBS

1 = keyed (non SAE)

2 = keyed (SAE BB)

3 = splined (SAE B) 13 teeth

4 = splined (SAE BB) 15 teeth

Modifications

Mounting w/connection variables

4 bolts SAE flange J518

	T7BB- T7BBS		T7BBS	
	Metric thread		UNC thread	
	M0	M1	00	01
P1	1"	3/4"	1"	3/4"
P2	3/4"			
S	2.1/2"			

Seal class

1 = S1 BUNA N - 0,7 bar max. (for mineral oil)

4 = S4 EPDM - 0,7 bar max. (for fire resistant fluids)

5 = S5 VITON® - 0,7 bar max. (for mineral oil and fire resistant fluids)

Design letter

Porting combination (see page 72)

00 = standard

Direction of rotation (shaft end view)

R = Clockwise

L = Counter-clockwise

INTERNAL LEAKAGE (TYPICAL)

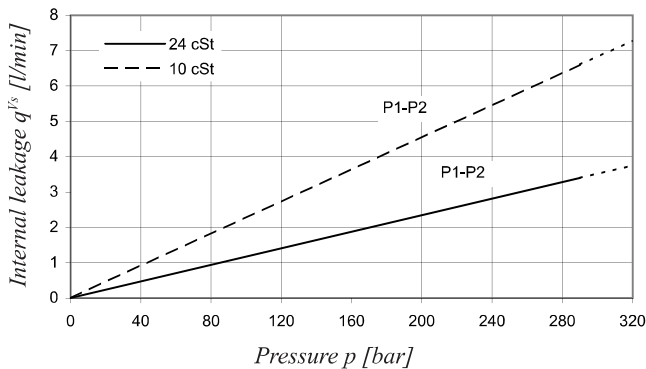

Do not operate pump more than 5 seconds at any speed or viscosity if internal leakage is higher than 50% of theoretical flow.

Total leakage is the sum of each section loss under its respective operating conditions.

POWER LOSS HYDROMECHANICAL (TYPICAL)

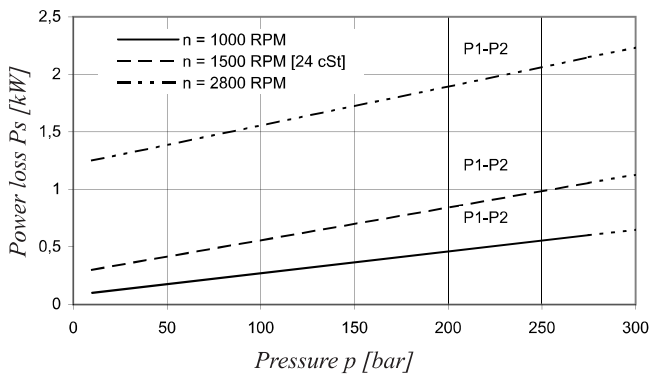

Total hydromechanical power loss is the sum of each section loss under its respective operating conditions.

NOISE LEVEL (TYPICAL) - T7BB - B10 - B04

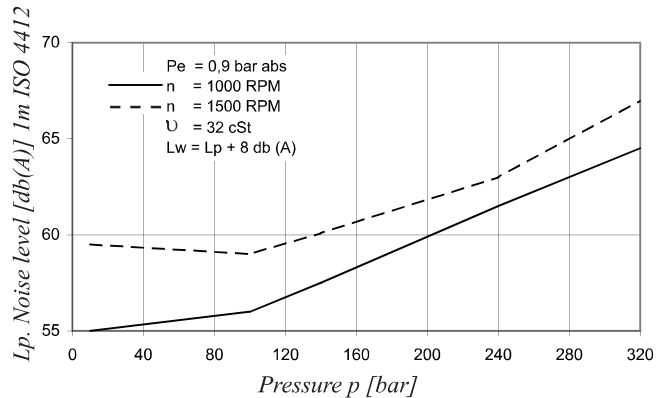

Double pump noise level is given with both stages discharging at the pressure value indicated on the curve.

PERMISSIBLE RADIAL LOAD

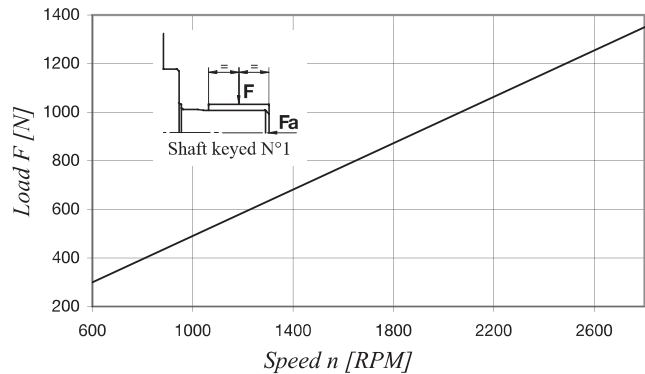

Maximum permissible axial load $F_a = 800\text{ N}$

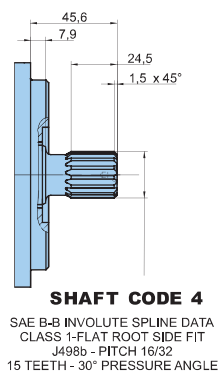
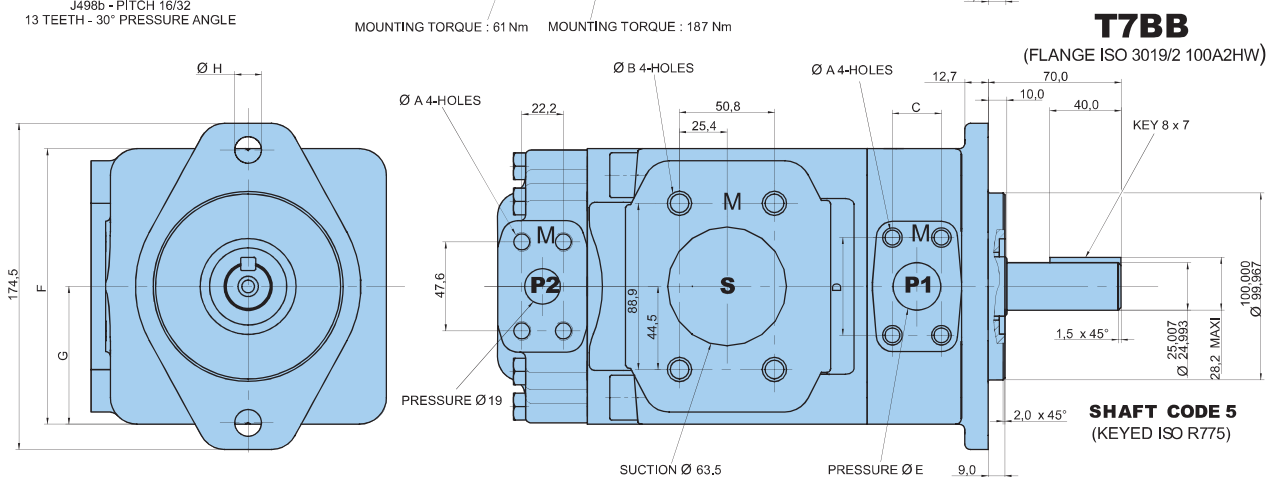
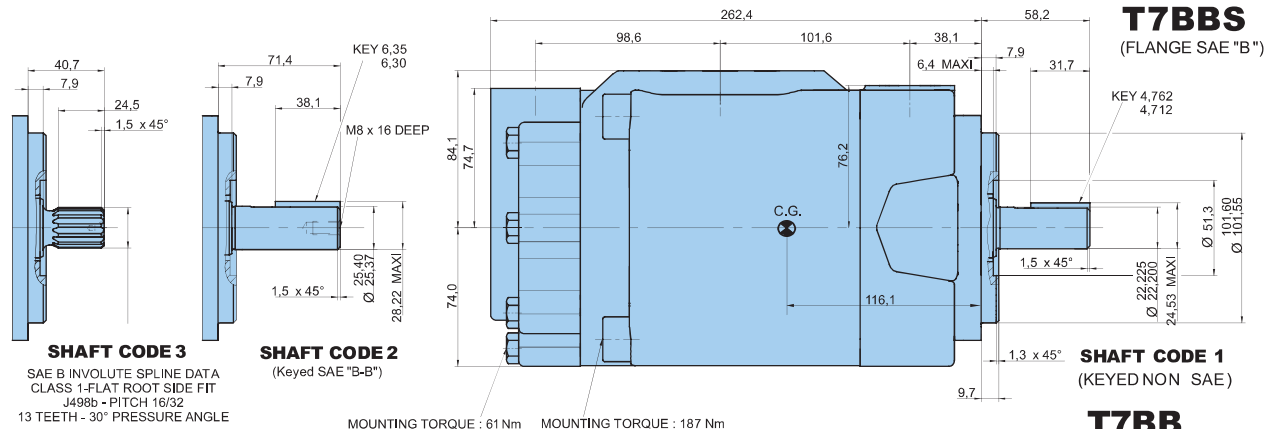

Shaft torque limits [ml/rev. x bar]	
Shaft	Vi x p max.
1	14300
2	21420
3	20600
4	32670
5	25300

Model	T7BB		T7BBS	
	M0	M1	00	01
Ø A	M10 x 19 deep		3/8"-16 UNC x 19 deep	
Ø B	M12 x 22,4 deep		1/2"-13 UNC x 22,4 deep	
C	26,20	22,25	26,20	22,25
D	52,4	47,65	52,4	47,65
Ø E	25,4	19,1	25,4	19,1
F	140		146	
G	70		73	
Ø H	14,0		14,3	

OPERATING CHARACTERISTICS - TYPICAL [24 cSt]

Pressure port	Series	Vi Volumetric displacement	Flow q _v [l/min] & n = 1500 RPM			Input power P [kW] & n = 1500 RPM		
			p = 0 bar	p = 140 bar	p = 320 bar	p = 7 bar	p = 140 bar	p = 320 bar
P1 & P2	B02	5,8 ml/rev	8,7	7,0	4,8	0,5	2,6	5,4
	B03	9,8 ml/rev	14,7	13,0	10,8	0,6	4,0	8,6
	B04	12,8 ml/rev	19,2	17,5	15,3	0,6	5,0	11,0
	B05	15,9 ml/rev	23,9	22,2	20,0	0,7	6,1	13,5
	B06	19,8 ml/rev	29,7	28,0	25,8	0,7	7,5	16,6
	B07	22,5 ml/rev	33,7	32,0	29,9	0,8	8,5	18,8
	B08	24,9 ml/rev	37,4	35,7	33,5	0,8	9,3	20,7
	B09	28,0 ml/rev	42,0	40,3	38,1	0,9	10,4	23,2
	B10	31,8 ml/rev	47,7	46,0	43,8	0,9	11,7	26,2
	B11	35,0 ml/rev	52,5	50,8	48,9 ¹⁾	1,0	12,8	27,0 ¹⁾
	B12	41,0 ml/rev	61,5	59,8	57,9 ¹⁾	1,1	14,9	31,5 ¹⁾
	B14	45,0 ml/rev	67,5	65,8	63,9 ¹⁾	1,2	16,3	34,5 ¹⁾
	B15	50,0 ml/rev	75,0	73,3	71,6 ²⁾	1,3	18,1	35,7 ²⁾

1) B11 - B12 - B14 = 300 bar max. int.

2) B15 = 280 bar max. int.