

# Series E Environmental Coils

**08-SIZE SERIES E COILS** (also for use on 98-size screw-in spool-type valves)

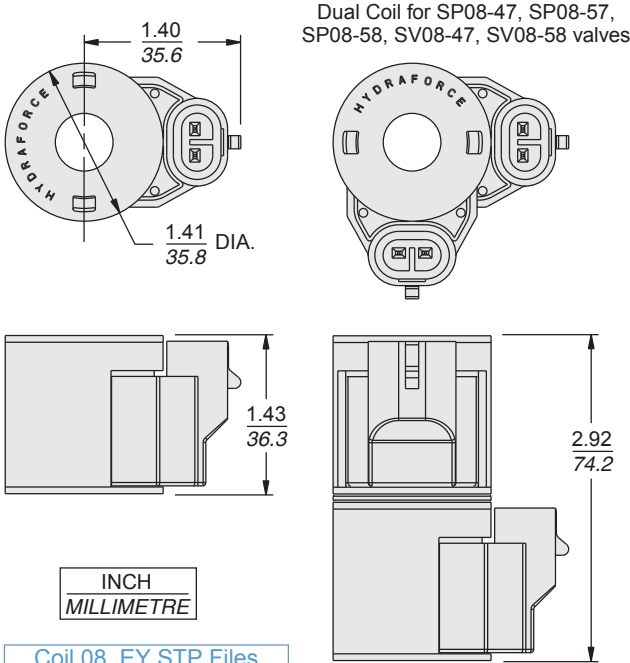

**EY**

**IP69K Rated 08-Size Coil  
Thermal Shock Dunk Test Rated Coil  
Metri-Pack® 150 Connector**

Mating Connector: Delphi Packard No. 12052641; HF Part No. 6110119

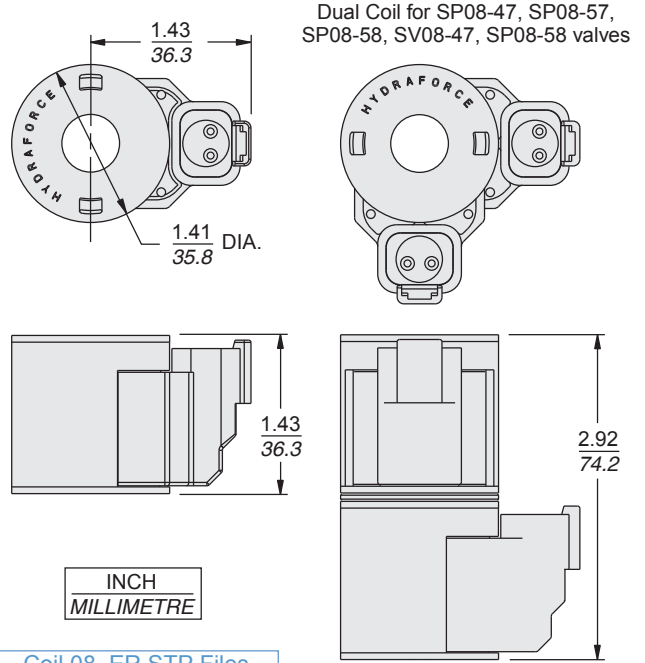

**ER**

**IP69K Rated 08-Size Coil  
Thermal Shock Dunk Test Rated Coil  
Deutsch DT04-2P Connector**

Mating Connector: Deutsch No. DT06-2S — HF Part No. 4001417

EY Coil Part No.	EY/Z* Coil Part No.	ER Coil Part No.	ER/Z* Coil Part No.	Operating Voltage	Resistance at 20°C	Initial Current Draw	Power	Coil Weight
4303410	4303810	4303610	4304010	10 VDC	6.2 ohms	1.6 amps	15.9 watts	136 g. (4.8 oz.)
4303412	4303812	4303612	4304012	12 VDC	8.8 ohms	1.4 amps	17.2 watts	136 g. (4.8 oz.)
4303420	—	4303620	4304020	20 VDC	23.9 ohms	0.8 amps	15.3 watts	136 g. (4.8 oz.)
4303424	4303824	4303624	4304024	24 VDC	33.8 ohms	0.7 amps	16.6 watts	136 g. (4.8 oz.)

\* Models with Zener Diode

**Note: Electrical specifications for Series E coils differ from those for standard HydraForce coils. (Refer to page 3.200.1 for standard coil specifications.)**

