

Proportional Solenoids for Hydraulics

4

Product group

G R C Y 037, 045, 062

- To VDE 0580
- Pressure-tight armature space, rated pressure 350 bar static
- Magnetic force vs stroke graph horizontal within proportional control range
- To a large extent proportional behaviour between force and current
- Small hysteresis through precise armature bearing
- Quick response times
- Push type
- Mounting via centre thread
- Simple exchange of the coil without opening the hydraulic circuit
- Coil to insulation rating F (H available on request)
- Electrical connection and protection if mounted properly:
 - Connection with sockets to DIN 46 247
Protection to DIN VDE 0470/EN 60 529 – IP00
 - Connection with plug connector to DIN 43 650
Screwed cable glands (4 x 90° positions)
Protection to DIN VDE 0470/EN 60 529 – IP 65
- Manual override
- Modifications and special designs, also with transducer, on request.
- Application examples:
Particularly used as proportional actuator in hydraulic control systems and control circuits



Fig. 1: G R C Y 062 N54 A01



Technical data

G RC Y ... N54 A01		037	045	062
Duty rating ED		S1 (100 %)	S1 (100 %)	S1 (100 %)
Reference temperature ϑ_{11}	(°C)	50	50	50
Overall stroke s	(mm)	4 +0,5	6 +1	8 +1
Working stroke s_w	(mm)	2	3	4
The indicated working stroke s_w is an approximate value. Owing to tolerances that occur, we recommend a stable operating range between	(mm)	0,5 - 1,5	0,5 - 2,5	0,5 - 3,5
Idle stroke s_L	(mm)	2	3	4
Rated magnetic force F_{MN}	(N)	47	53,5	112
Rated magnetic force H_{FN} dynamic	(%)	≈ 4	≈ 4	≈ 5
Measured with measuring speed	(mm/min)	20	30	40
Rated current hysteresis H_{IN}	(%)	< 3	< 3	< 4
Rated linearity deviation L_N	(%)	≈ 2	≈ 2	≈ 2
Armature weight m_A	(kg)	0,04	0,05	0,16
Solenoid weight m_M	(kg)	0,41	0,57	1,57
Rated voltage U_N	(V)	24	24	24
Rated resistance R_{20}	(Ω)	13	14	7,38
Rated current I_N	(A)	0,94	0,96	1,7
Maximum current I_G	(A)	0,94	0,96	1,7
Linearity current I_L	(A)	≈ 0,20	≈ 0,22	≈ 0,32
Response current I_A	(A)	≈ 0,04	≈ 0,034	≈ 0,12
Rated power $P_N = I_N^2 \cdot R_{20}$	(W)	11,5	12,9	21
Maximum power $P_G = I_G^2 \cdot R_W$	(W)	17,3	19,5	32,2
The maximum power requires mounting on a hydraulic valve	hydraulic valve (mm)	46 x 46 x 66	46 x 46 x 66	67 x 67 x 82
Base plate with the following minimum dimensions	base plate (mm)	66 x 46 x 30	66 x 46 x 30	102 x 115 x 30
Linearity power $P_L = I_L^2 \cdot R_{20}$	(W)	0,5	0,7	0,76
Response power $P_A = I_A^2 \cdot R_{20}$	(W)	0,02	0,016	0,1

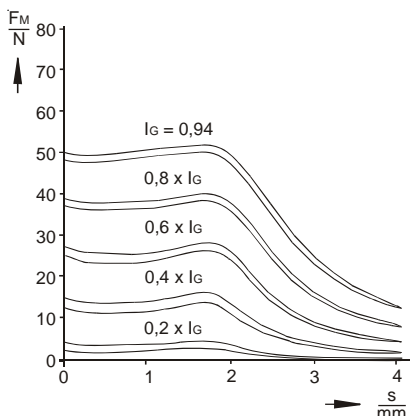

Fig. 2: Magnetic force v stroke graph size 037

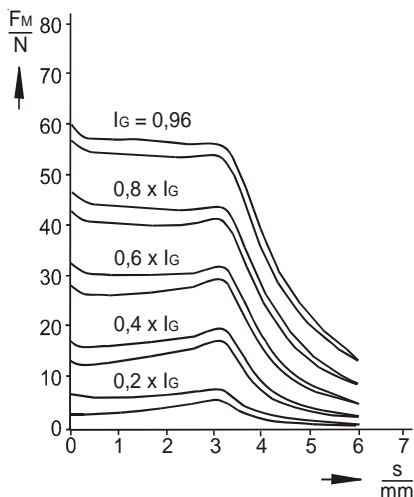

Fig. 3: Magnetic force v stroke graph size 045

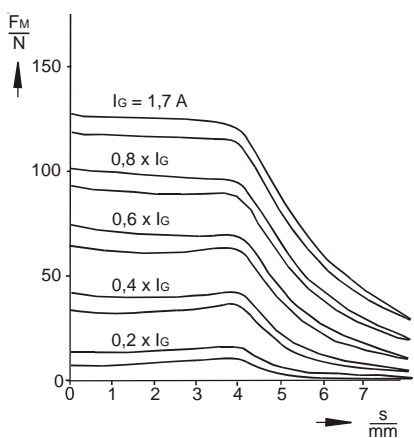

Fig. 4: Magnetic force v stroke graph size 062

Hot condition is based on:

- a) mounting on a hydraulic slide-valve, filled with oil, dimensions as indicated in table
- b) Rated voltage \approx 24 V
- c) Relative duty rating S1 (100 % ED)
- d) Reference temperature 50° C

For different and modified applications, a reduction of the coil winding may be necessary. With other valve dimensions and different reference temperatures, the magnetic force may be adapted by modification of the coil winding.

The indicated technical data refer to an A.C. power supply with bridge rectifier. The coil winding can be adjusted to other current and resistance values on request.

Owing to natural dispersion magnetic-force values may deviate by \pm 5% from the listed values.

On request, armature space can be deaerated and pushrod can be adjusted.

Solenoid interior and armature bearing are resistant to all neutral fluids that are commonly used in hydraulics. Please contact us if you intend to use other operating media.

Please make sure that the described devices are suitable for your application. Please find further details and definitions in our  Technical Explanation or, respectively, in VDE 0580.

Note on the technical harmonisation guidelines within the EU



Electromagnetic solenoids of this product range are subject to the low-voltage guideline 73 / 23 EWG.

To guarantee the targets of this regulation, products are manufactured and inspected to the valid edition of DIN VDE 0580. This also equals a declaration of conformity by the manufacturer.

Note on the EMC (electromagnetic compatibility) guideline 89/336 EWG

Electromagnetic solenoids are not affected by this guideline because neither do they cause electromagnetic disturbances, nor can they be disturbed through electromagnetic disturbances. Therefore, the adherence to the EMC guideline has to be guaranteed by the user through appropriate circuitry wiring. Examples for protection circuits can be taken from the corresponding technical documents.



Coil

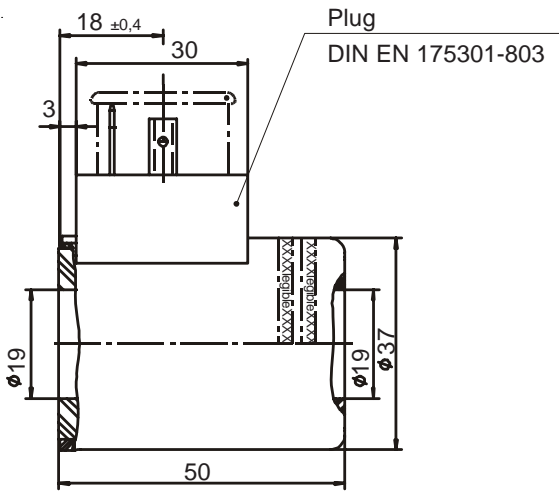

Fig. 5: Size 037 (Type No. FHMG037923689)

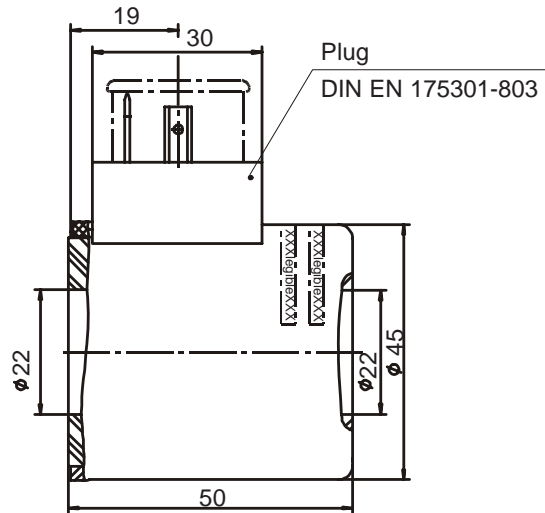

Fig. 6: Size 045 (Type No. FHMG045923385)

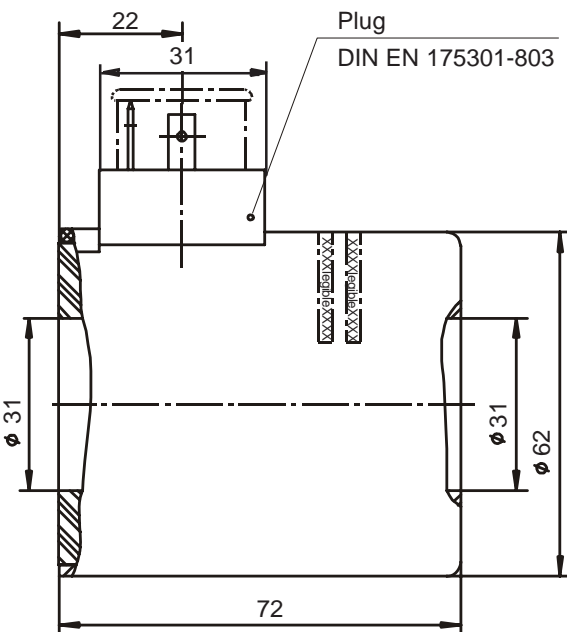

Fig. 7: Size 062 (Type No. FHMG062923688)

The solenoid shown is not a ready-to-use device in the sense of DIN VDE 0580. The general requirements and protective measures to be taken by the user, are included in DIN VDE 0580.

Tube

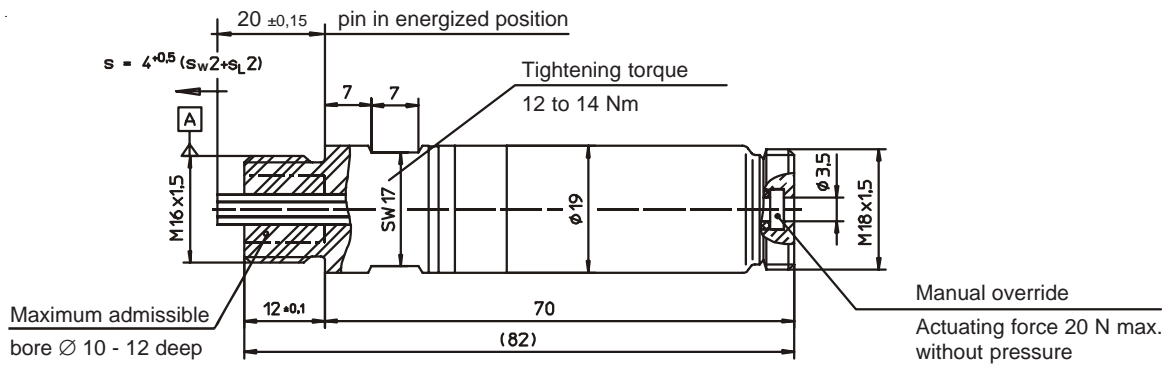

Fig. 8: Size 037 Type No. FHTP037923678

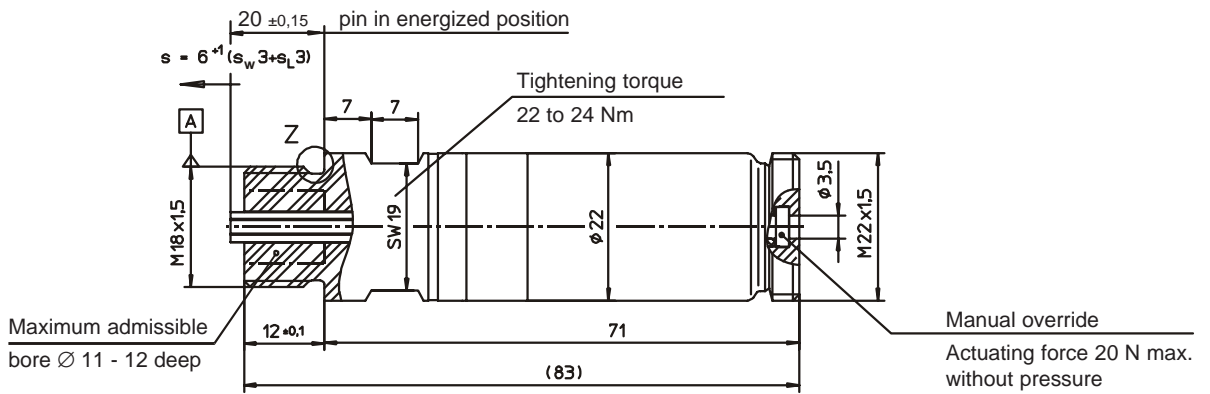

Fig. 9: Size 045 Type No. FHTP045923681

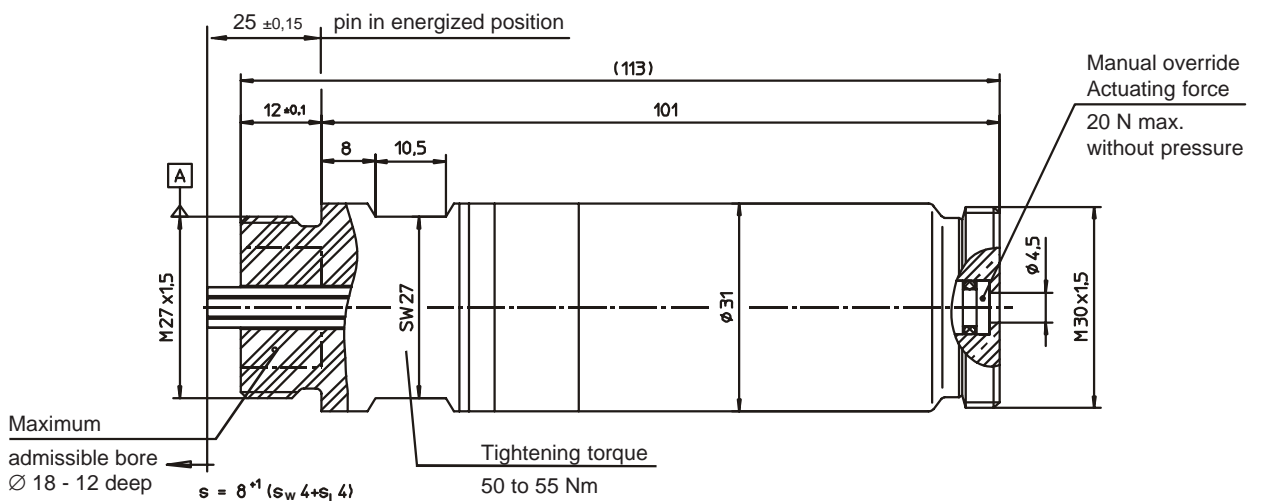

Fig. 10: Size 062 Type No. FHTP062923683



Fixing Nut

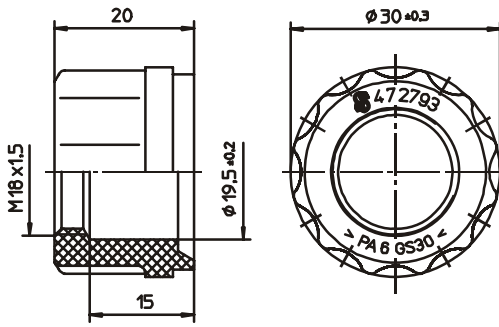

Fig. 11: Size 037 (Type No. 472793)
suitable socket wrench SW26 (bihex DIN 3124)
O-Ring to be used: 19 x 2,5 70 Shore A
tightening torque 5 ⁺¹ Nm

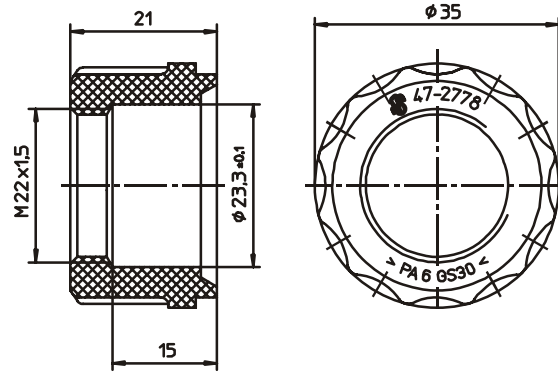

Fig. 12: Size 045 (Type No. 472778)
suitable socket wrench SW30 (bihex DIN 3124)
O-Ring to be used: 22 x 2,5 70 Shore A
tightening torque 6 ⁺¹ Nm

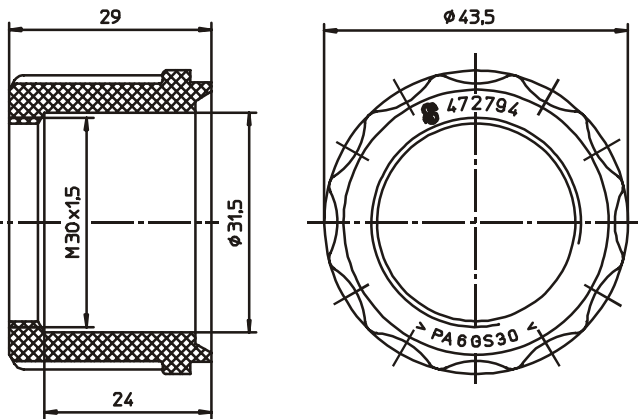
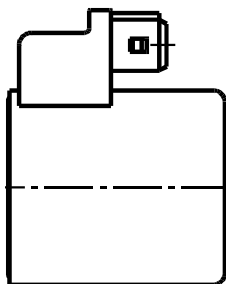
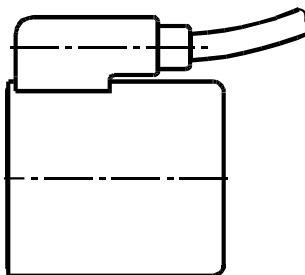

Fig. 13: Size 062 (Type No. 472794)
suitable socket wrench SW38 (bihex DIN 3124)
O-Ring to be used: 31 x 2,5 70 Shore A
tightening torque 6 ⁺¹ Nm

Further variations for the electrical connection on request



2-pole
AMP-Junior-Timer



connecting
cable

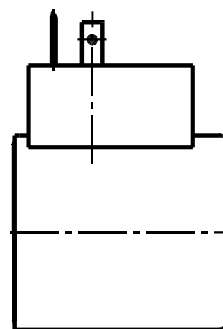

plug connector
DIN 43650 with
bridge rectifier

Connection variations for tube centre thread

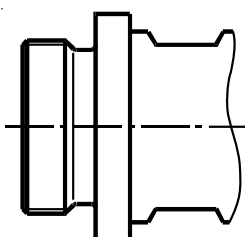

bigger thread
with collar

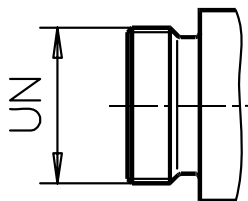

UN-thread
(also UNF, UNEF, etc.)

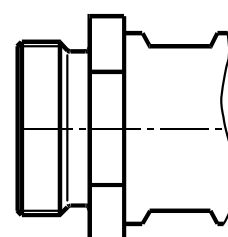

bigger thread with
hexagonal collar



Type code

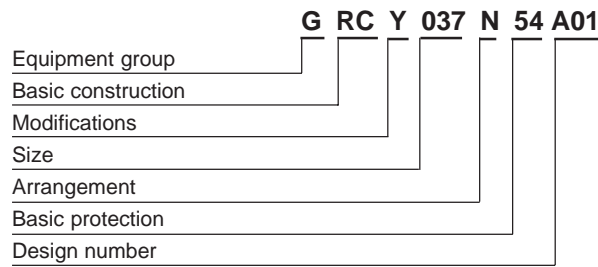

Order Example

Type	G RC Y 037 N54 A01
Voltage	24 V DC
Operating mode	S1 (100 %)

Specials

Special designs and modifications are available on request for which full application conditions should be specified in accordance withour -Technical Explanations.