

- **Langsamlaufender Gerotor-Motor**
  - **Spezielle Orbital-Steuerung**  
Geringe interne Leakage  
Hoher volumetrischer Wirkungsgrad
  - **Rollen im Rotorsatz**  
Reduzierte Reibung  
Lange Lebensdauer
  - **Patentierte Hochdruckwellendichtung**  
Keine Leckölleitung  
Keine Rückschlagventile
  - **Vielzahl von Varianten**  
Großer Einsatzbereich
- **Low Speed Gerotor Motor**
  - **Zero leak commutation valve**  
For greater, more consistent volumetric efficiency
  - **Roller vane rotor set**  
Reduces friction and internal leakage  
Maintaining efficiency throughout the life of the motor
  - **A patented high-pressure shaft seal**  
No check valves needed  
No extra plumbing
  - **Wide choice of displacement range, flange and shaft options**  
Greater efficiency in systems design to suit your application
- **Moteur lent système Gerotor**
  - **Une distribution orbitale particulière assure**  
fuites internes minimales  
rendements volumétriques élevés
  - **Le rotor à rouleaux**  
réduit les frottements  
augmente la durée de vie
  - **Par l'utilisation de joints d'arbre haute pression brevetés**  
pas de conduite de drainage  
pas de clapets anti-retour
  - **Grâce à de nombreuses variantes**  
larges domaines d'application
- **Motore orbitale a bassa velocità**
  - **Una particolare distribuzione orbitale assicura**  
trafilamento ridotto  
elevato rendimento volumetrico
  - **Con lo statore a rullini**  
si riduce l'attrito interno  
si mantiene nel tempo l'efficienza del motore
  - **Una guarnizione di tenuta ad alta pressione brevettata elimina la necessità**  
di una linea di drenaggio esterna  
e di valvole di non ritorno
  - **Un'ampia gamma di cilindrate, flange ed alberi**  
consentono scelte adeguate ad ogni esigenza costruttiva

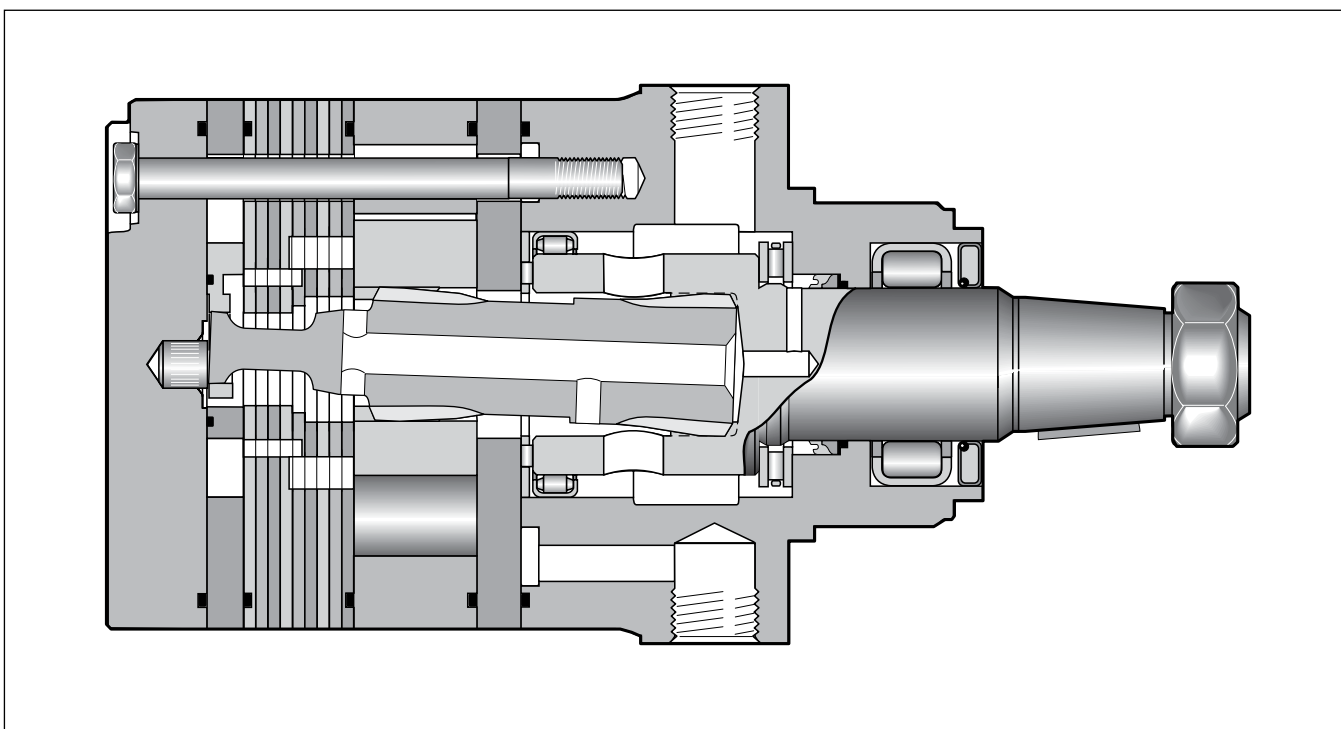

**Performance**

**Torqmotor  
Series TG**

Drehzahl Speed Vitesse de rotation Velocità di rotazione	max. 710 rev/min
Schluckstrom Oil flow Débit d'huile Portata	max. 115 l/min
Eingangsdruck Supply pressure Pression entrée Pressione in entrata	max. 300 bar
Torque Couple Coppia	max. 1490 Nm
Seitenlast Side load Charges latérales Carico radiale	max. 16.000 N See page 51

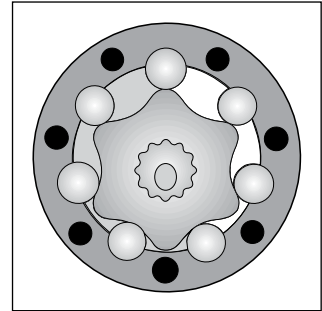
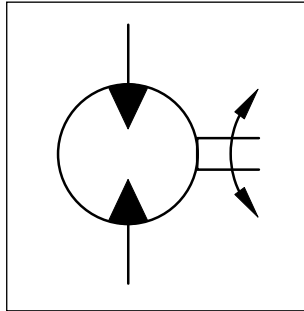

Motor series TG	Geom. Schluckvolumen Geometric displacement Cylindrée	Max. Drehzahl Max. speed Vitesse de rotation maxi Velocità di rotazione max	Max. Schluckstrom Max. oil flow Débit d'huile maxi Portata max	Max. Druckdifferenz ** Max. differential pressure ** Chute de pression maxi ** Caduta di pressione max **	Max. Eingangsdruck Max. supply pressure Pression maxi entrée Pressione max in entrata	Max. Drehmoment Max. torque Couple maxi Coppia max	Max. Leistungsabgabe Max. performance Puissance de sortie max Potenza meccanica max	Min. Anlaufmoment Min. starting torque Couple min. fourni au démarrage Coppia min. di spunto
	[cm <sup>3</sup> /U] [cm <sup>3</sup> /rev]	cont / int* [U/min] [rev/min]	cont / int* [l/min]	cont / int* [bar]	max [bar]	cont / int* [Nm]	cont / int* [KW]	cont / int* [Nm]
TG 140	141	530/710	75/100	210/280	300	400/545	33	320/436
TG 170	169	440/575	75/100	210/280	300	485/670	33	388/536
TG 195	195	380/510	75/100	210/280	300	560/770	33	448/616
TG 240	238	320/420	75/100	210/280	300	685/945	32	548/756
TG 280	280	270/350	75/100	210/280	300	800/1100	31	675/880
TG 335	337	225/290	75/100	210/280	300	980/1350	30	784/1080
<b>TG 405</b>	<b>405</b>	<b>185/245</b>	<b>75/100</b>	<b>170/240</b>	<b>300</b>	<b>960/1350</b>	<b>27</b>	<b>791/1145</b>
TG 475	477	160/240	75/115	140/210	300	960/1400	28	768/1120
TG 530	529	140/215	75/115	140/170	300	1050/1280	23	874/1091
TG 625	613	120/185	75/115	120/160	300	1040/1360	20	895/1165
TG 785	786	95/145	75/115	100/140	300	1150/1490	17	991/1341
TG 960	959	78/119	75/115	70/100	300	925/1390	12	763/1177

\*int. =  
Intermittierende Werte maximal: 10% von jeder Betriebsminute.  
Intermitt operation rating applies to 10% of every minute.  
Fonctionnement interm.: 10% max. de chaque minute d'utilisation.  
Servizio intermittente: 10% max di ogni minuto di utilizzazione.

\*\* Druckdifferenz Δp zwischen Ein- und Ausgang  
\*\* Pressure difference is Δp between input and output  
\*\* La différence de pression est Δp entre l'entrée et la sortie  
\*\* La differenza di pressione corrisponde al Δp tra ingresso e uscita

**Ordering Code**

**Torqmotor Series TG**



**TG** Serie Series Série Serie  
**0405** Schluckvolumen Displacement Cylindrée Cilindrata  
**M** Gehäuse Housing Carter Corpo motore  
**W** Anschluss Ports Plan de raccordement Connessioni  
**46** Welle Shaft Arbore Albero  
**0** Drehrichtung Direction of rotation Direction de rotation Direzione di rotazione  
**A A A B** Option

For further options different to standard 'AAAB' see page 80.

Code	cm <sup>3</sup> /rev
0140	140
0170	169
0195	195
0240	237
0280	280
0335	337
X 0405	405
0475	476
0530	529
0625	624
0785	786
0960	958

Code	Front port
X W	G 1/2
V	7/8-14 UNF O-Ring
N <sup>2)</sup>	Universal-M8x13
K <sup>3)</sup>	Universal-M6x12

<sup>2)</sup> Nicht verfügbar für Gehäuse "H"  
 Not possible for housing "H"  
 Pas disponible pour carter "H"  
 Non Disponibile con il corpo codice "H"  
<sup>3)</sup> Nicht verfügbar für Gehäuse "M, E, V"  
 Not possible for housing "M, E, V"  
 Pas disponible pour carter "M, E, V"  
 Non disponibile con il corpo codice "M, E, V"

Code	Housing
E	
X M	
H	
V <sup>1)</sup>	

<sup>1)</sup> Nur verfügbar mit Endanschluss  
 Only possible with rear port  
 Possible seulement avec orifice arrière  
 Possible solo con connessioni posteriori

Code	Rear port
Y	G 1/2 Axial
A	7/8-14 UNF Axial
X	G 1/2 Radial
B	7/8-14 UNF Radial
L	Universal Radial M8x13

Code	Front port
X 0	Standard
1	

Code	Rear port
0	Standard
1	

Code	Shaft
44	Pitch 12/24
45	31.75
08	
X 46	32
92	34.85
94	35

**Code E**

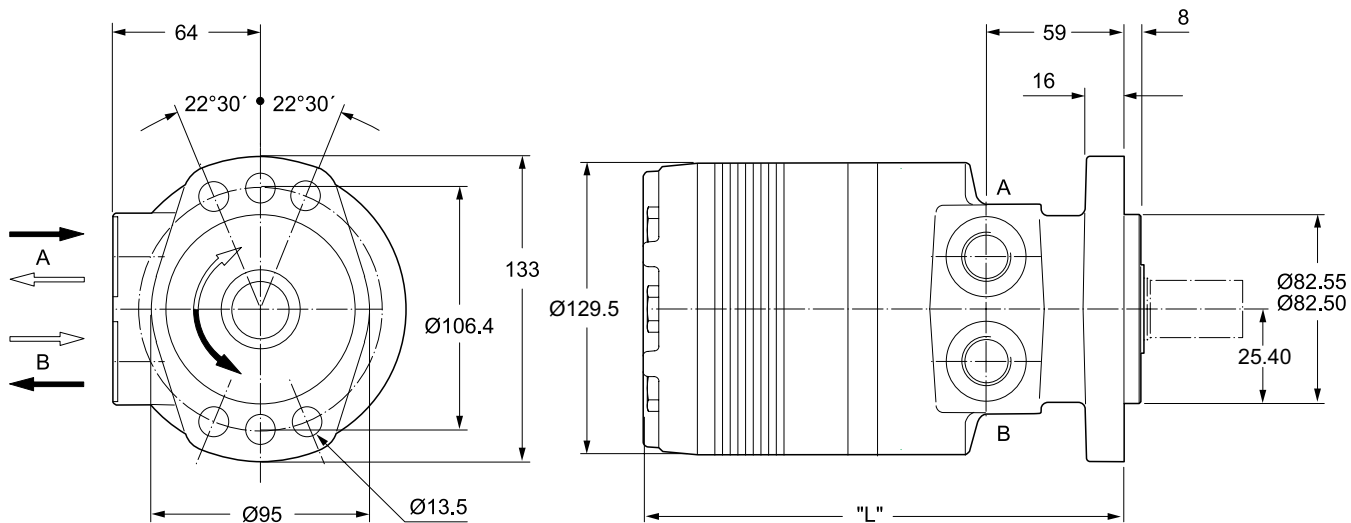

**Code M**

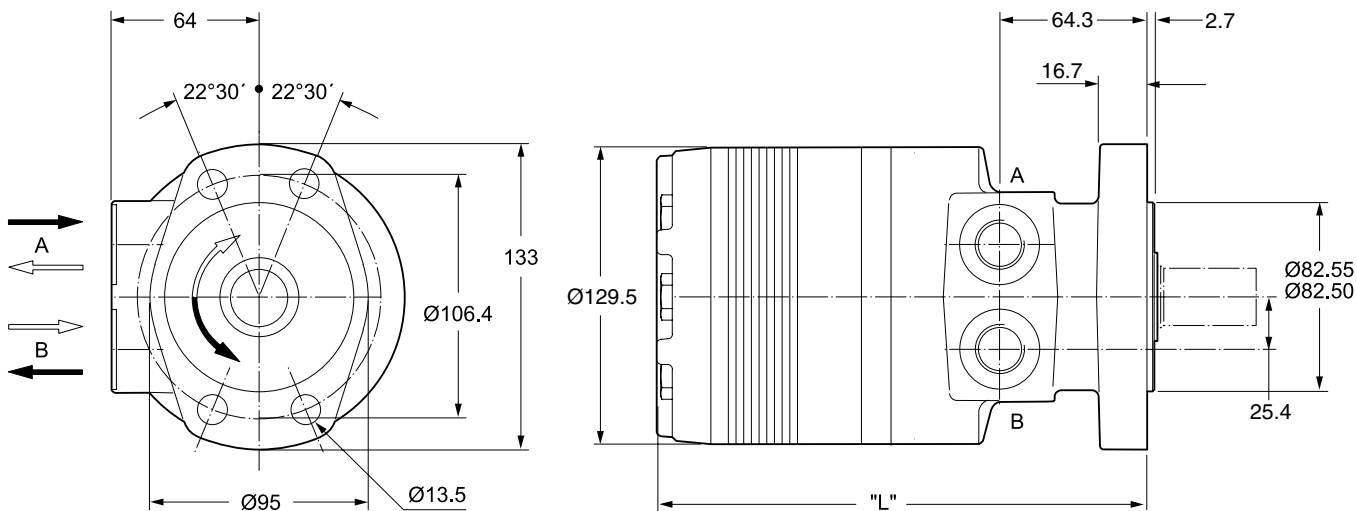

Gewicht / Weight	TG140	TG170	TG195	TG240	TG280	TG335	TG405	TG475	TG530	TG625	TG785	TG960
Poids / Peso [kg]	14.2	14.5	14.7	15.1	15.5	15.9	16.5	17.2	17.9	18.6	20.2	22.0
Code E "L" [mm]	191	194	197	202	207	213	220	229	235	245	264	283
Code M "L" [mm]	196	199	202	208	212	218	225	234	240	250	269	288

**Code W**

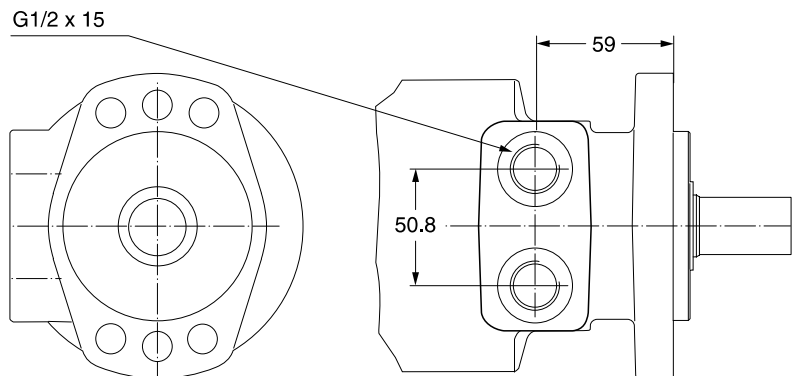

**Code: N**

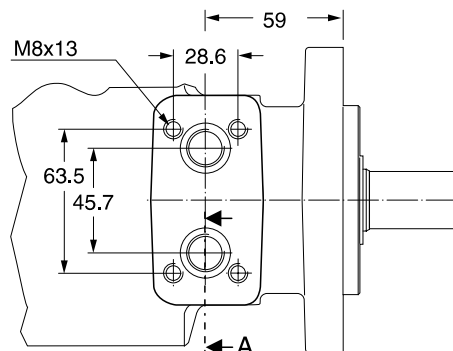

**Code W**

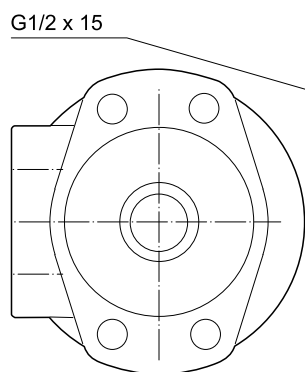

**Code V**

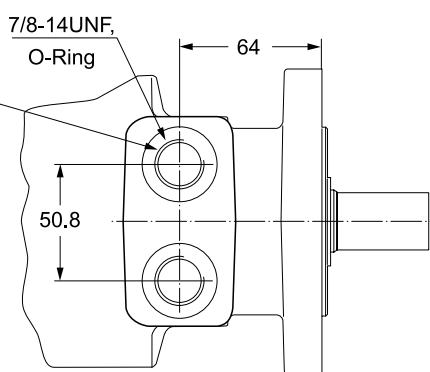

**Code N**

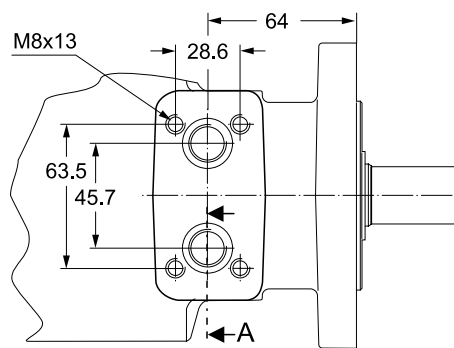

**Code W**

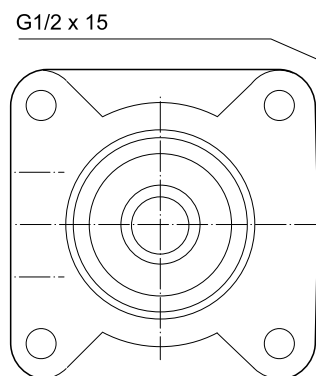

**Code V**

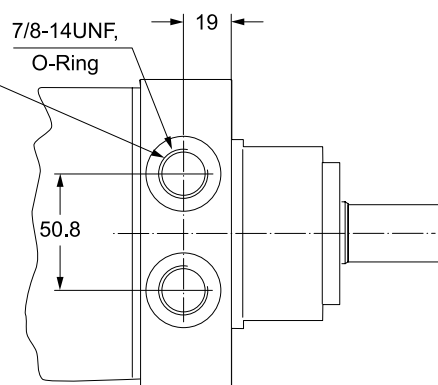

**Code K**

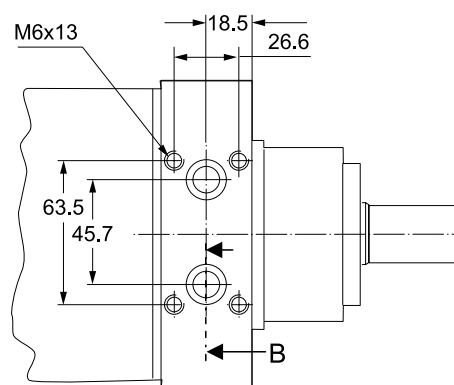

**Section A**

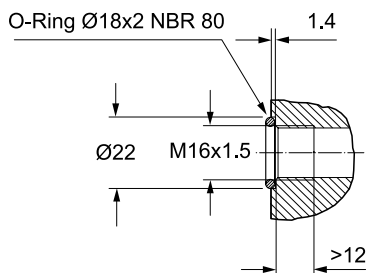

**Section B**

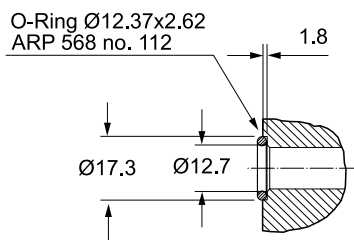

Zum Motor mit Universalanschluss werden 2 O-Ringe geliefert.

Motor with manifold mount is supplied with 2 O-rings.

Deux joints toriques sont livrés avec les moteurs au plan de raccordement universel.

Il blocchetto connessioni è corredato da 2 OR.

**Code 44**

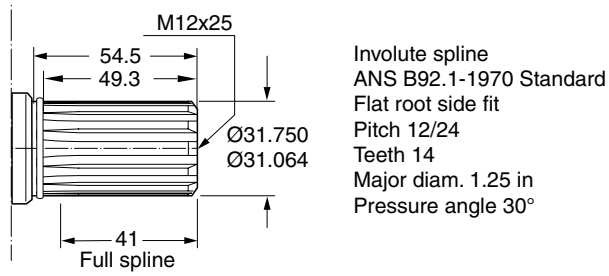

**Code 45**

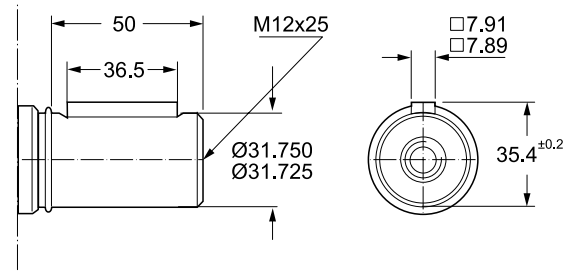

**Code 08**

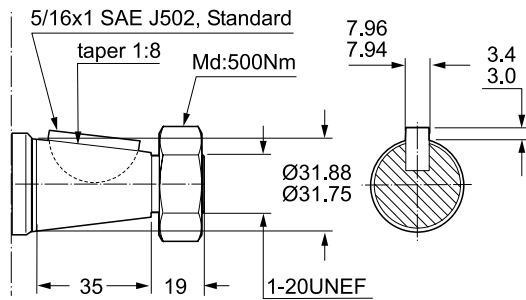

**Code 46**

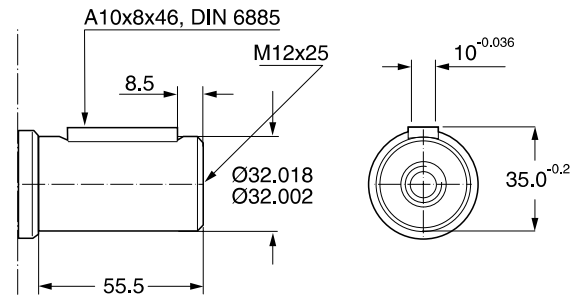

\* On request shaft with 35mm diameter

**Code 92**

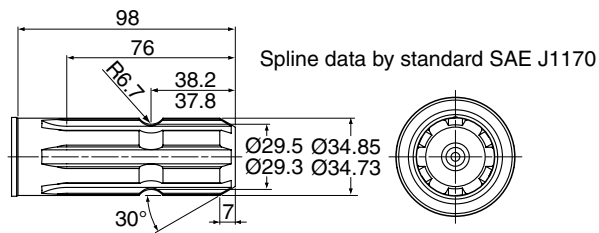

**Code 94**

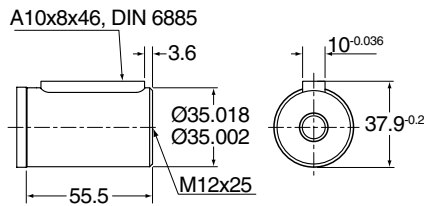

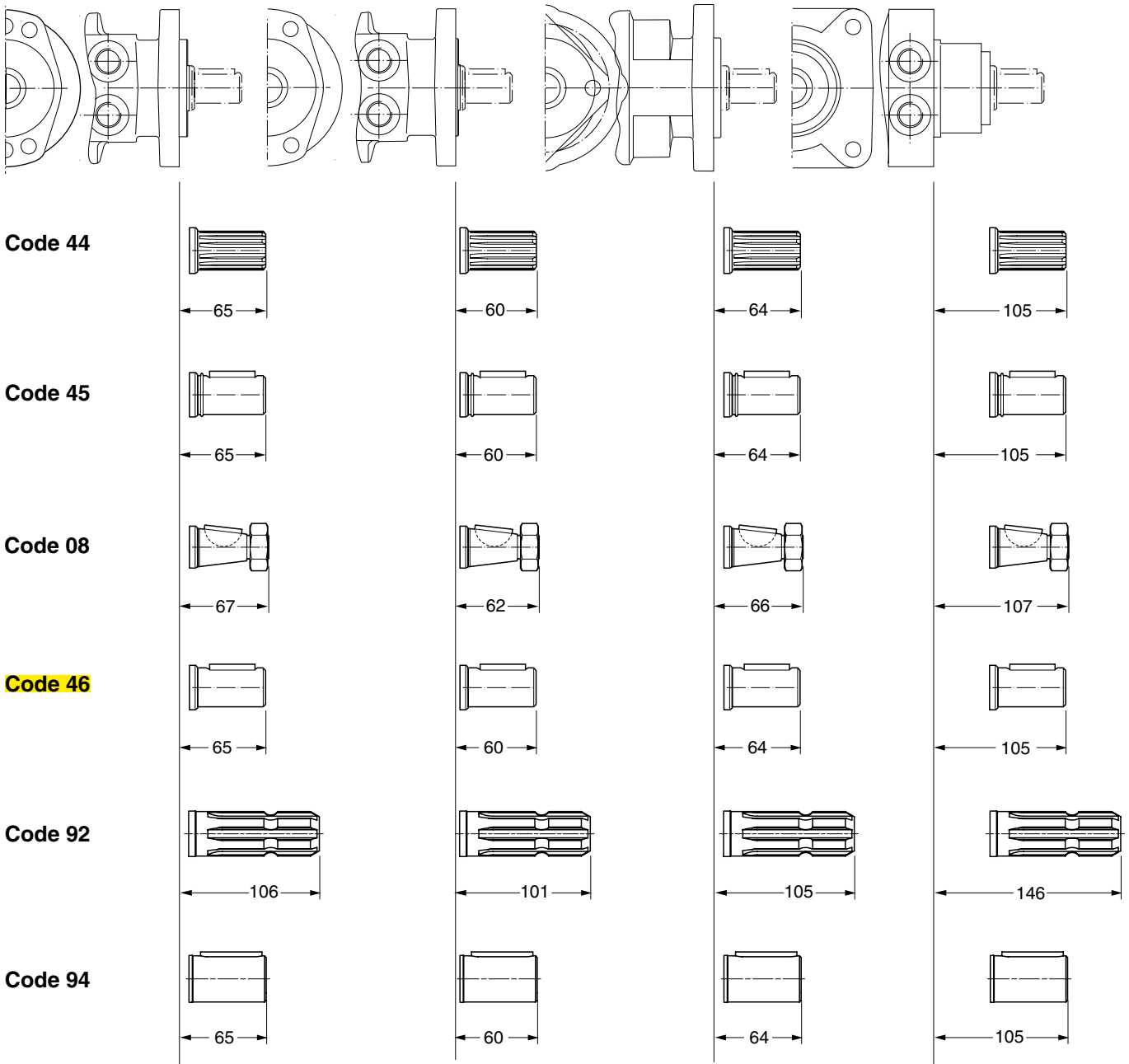

Option Codes

Option Code	Description	Series	TE/TJ	TF	TL	TG	TH	TK
AAAA	black paint		x	x	x	x	x	x
AAAB	standard (no paint)		x	x	x	x	x	x
AAAH	FPM seals (no paint)		x	x		x	x	x
AABP	castle nut (no paint)		x	x		x	x	x
AAFX	shuttle valve			x		x	x	
BBBF	internal relief valve 200bar			x		x	x	
BBBJ	internal relief valve 100bar			x		x	x	
BBBM	internal relief valve 70bar			x		x	x	
X BBBN	internal relief valve 140bar			x		x	x	
BBCG	internal relief valve 170bar			x		x	x	
HAAF	external relief valve 100bar (M6)			x		x		
HAAP	external relief valve 100bar (M8)		x	x		x	x	
HAAH	external relief valve 140bar (M6)			x		x		
HAAU	external relief valve 140bar (M8)		x	x		x	x	
HAAK	external relief valve 170bar (M6)			x		x		
HAAX	external relief valve 170bar (M8)			x		x	x	
HAAM	external relief valve 200bar (M6)			x		x		
HABA	external relief valve 200bar (M8)			x		x	x	
FSAB	Speedsensor		X	x		x		
FSAA	Speedsensor + black paint		x	x		x		
FSAN	Int Short Speed Sensor, 1500 psi Int Bidirectional Relief, No paint			x		x		