

HYDRAULIC MOTOR-BRAKE B/MR

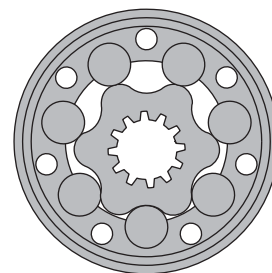

APPLICATION

- » Conveyors
- » Feeding mechanism of robots and manipulators
- » Metal working machines
- » Textile machines
- » Agricultural machines
- » Food industries
- » Mining machinery etc.



CONTENTS

Specification data	22+23
Dimensions and mounting	24+25
Shaft extensions	25
Permissible shaft loads	26
Order code	26

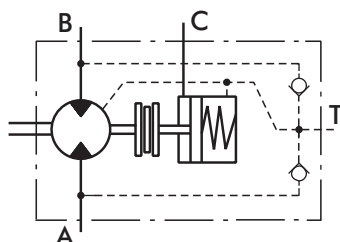

OPTIONS

- » Model - Spool valve, roll-gerotor
- » Fully integrated friction disk brake
- » Side port
- » Shaft - straight
- » BSPP ports

GENERAL

Max. Displacement, cm ³ /rev [in ³ /rev]	397 [24.4]
Max. Speed, [RPM]	600
Max. Torque, daNm [lb-in]	cont.: 61 [5400] int.: 57 [5045]
Max. Output, kW [HP]	14,5 [19.5]
Max. Pressure Drop, bar [PSI]	cont.: 175 [2540] int.: 200 [2900]
Max. Oil Flow, lpm [GPM]	75 [19.8]
Min. Speed, [RPM]	10
Permissible Shaft Loads, daN [lb-in]	P _a =200 [450]
Pressure fluid	Mineral based- HLP(DIN 51524) or HM(ISO 6743/4)
Temperature range, °C [°F]	-40÷140 [-40÷284]
Optimal Viscosity range, mm ² /s [SUS]	20÷75 [98÷347]
Filtration	ISO code 20/16 (Min. recommended fluid filtration of 25 microns)

Oil flow in drain line

Pressure drop bar [PSI]	Viscosity mm ² /s [SUS]	Oil flow in drain line lpm [GPM]
100 [1450]	20 [98]	2,5 [.660]
	35 [164]	1,8 [.476]
140 [2030]	20 [98]	3,5 [.925]
	35 [164]	2,8 [.740]

Pressure Losses

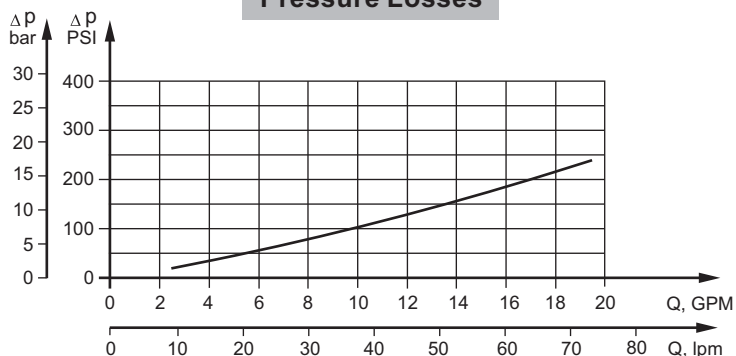

SPECIFICATION DATA

Type		B/MR 80	B/MR 100	B/MR 125	B/MR 160	B/MR 160 CB	B/MR 200	B/MR 200 CB
Displacement, cm ³ /rev [in ³ /rev]		80,3	99,8	125,7	159,6		199,8	
		[4.90]	[6.09]	[7.67]	[9.74]		[12.19]	
Max. Speed, [RPM]	Cont.	500	500	475	375		300	
	Int.*	600	600	600	470		375	
Max. Torque, daNm [lb-in]	Cont.	19,5 [1725]	24 [2125]	30 [2655]	30 [2655]	39 [3450]	30 [2655]	45 [3980]
	Int.*	22[1947]	28 [2480]	34 [3010]	39 [3450]	43 [3805]	39 [3450]	50 [4425]
	Peak**	27 [2390]	32 [2832]	37 [3275]	46 [4070]	46 [4070]	56 [4960]	56 [4955]
Max. Output, kW [HP]	Cont.	8,4 [11.2]	10,8 [14.5]	12,5 [16.8]	10 [13.4]	11,5 [15.4]	7,8 [10.5]	11 [14.75]
	Int.*	9,6 [12.9]	12 [16.1]	14,5 [19.5]	12,5 [16.8]	14 [18.8]	12,4 [16.6]	13 [17.4]
Max. Pressure Drop, bar [PSI]	Cont.	175 [2540]	175 [2540]	175 [2540]	135 [1960]	175 [2540]	105 [1523]	175 [2540]
	Int.*	200 [2900]	200 [2900]	200 [2900]	175 [2540]	200 [2900]	145 [2103]	200 [2900]
	Peak**	225 [3263]	225 [3263]	225 [3263]	225 [3263]	225 [3263]	225 [3263]	225 [3263]
Max. Oil Flow, l/min [GPM]	Cont.	40 [10.5]	50 [13.2]	60 [15.9]	60 [15.9]		60 [15.9]	
	Int.*	48 [12.7]	60 [15.9]	75 [19.8]	75 [19.8]		75 [19.8]	
Max. Inlet Pressure, bar [PSI]	Cont.	175 [2540]						
	Int.*	200 [2900]						
	Peak**	225 [3260]						
Max. Starting Pressure, bar [PSI]		10 [145]	10 [145]	9 [130]	7 [102]		5 [73]	
Min. Starting Torque, daNm [lb-in]	At max.press.drop Cont	15 [1330]	20 [1770]	25 [2215]	24 [2124]	32 [2832]	26 [2301]	41 [3628]
	At max.press.drop Int.*	17 [1505]	23 [2035]	28 [2480]	32 [2832]	37 [3275]	33 [2920]	46 [4071]
Min. Speed***, [RPM]		10	10	10	10	10	10	10
Static Torque of Brake, daNm [lb-in]		55 [4868]						
Min. Brake Release Pressure****, bar [PSI]		13 [190]						
Max. Opening Pressure, bar [PSI]		200 [2900]						
Weight, kg [lb]		11,0 [24.3]	11,2 [24.7]	11,4 [25.2]	11,6 [25.6]	11,7 [25.8]	12,2 [26.9]	12,3 [27.12]

* Intermittent operation: the permissible values may occur for max. 10% of every minute.

** Peak load: the permissible values may occur for max. 1% of every minute.

*** For speeds lower than given, consult factory or your regional manager.

**** Motor-brakes must always have a drain line. The brake release pressure is the difference between the pressure in the brake release line and the pressure in the drain line.

1. Intermittent speed and intermittent pressure must not occur simultaneously.
2. Recommended filtration is per ISO cleanliness code 20/16. A nominal filtration of 25 micron or better.
3. Recommend using a premium quality, anti-wear type mineral based hydraulic oil HLP(DIN51524) or HM (ISO 6743/4).
If using synthetic fluids consult the factory for alternative seal materials.
4. Recommended minimum oil viscosity 13 mm²/s [70 SUS] at 50°C [122°F].
5. Recommended maximum system operating temperature is 82°C [180°F].
6. To assure optimum motor life fill with fluid prior to loading and run at moderate load and speed for 10-15 minutes.

SPECIFICATION DATA (continued)

Type		B/MR 250	B/MR 250 CB	B/MR 315	B/MR 315 CB	B/MR 400	B/MR 400 CB
Displacement, cm ³ /rev [in ³ /rev]		250,1 [15.26]		315,7 [19.26]		397 [24.4]	
Max. Speed, [RPM]	Cont.	240		190		150	
	Int.*	300		240		190	
Max. Torque daNm [lb-in]	Cont.	30 [2655]	54 [4780]	30 [2655]	55 [4868]	30 [2655]	55 [4868]
	Int.*	39 [3450]	57 [5045]	42 [3717]	57 [5045]	43 [3805]	57 [5045]
	Peak**	60 [5310]	71 [6285]	61 [5400]	71 [6285]	60 [5310]	70 [6195]
Max. Output kW [HP]	Cont.	6,2 [8.3]	10 [13.4]	4,5 [6.1]	9 [12.1]	2,2 [2.9]	7 [9.4]
	Int.*	9,5 [12.7]	11 [14.7]	7,5 [10.1]	10 [13.4]	5,6 [7.5]	8,7 [11.7]
Max. Pressure Drop, bar [PSI]	Cont.	85 [1233]	175 [2540]	65 [942]	135 [1958]	45 [652]	105 [1523]
	Int.*	115 [1668]	185 [2683]	90 [1305]	145 [2103]	75 [1087]	115 [1668]
	Peak**	200 [2900]	225 [3263]	150 [2175]	180 [2610]	120 [1740]	140 [2030]
Max. Oil Flow l/min [GPM]	Cont.	60 [15.9]					
	Int.*	75 [19.8]					
Max. Inlet Pressure bar [PSI]	Cont.	175 [2540]					
	Int.*	200 [2900]					
	Peak**	225 [3260]					
Max. Starting Pressure bar [PSI]		5 [73]		5 [73]		5 [73]	
Min. Starting Torque, daNm [lb-in]	At max.press.drop Cont	24 [2125]	50 [4425]	26 [2300]	50 [4425]	24 [2125]	44 [3895]
	At max.press.drop Int.*	31 [2745]	51,5 [4560]	35 [3100]	51,8 [4585]	38 [3364]	50 [4425]
Min. Speed***, [RPM]		10	10	10	10	10	10
Static Torque of Brake, daNm [lb-in]		55 [4868]					
Min. Brake Release Pressure****, bar [PSI]		13 [190]					
Max. Opening Pressure, bar [PSI]		200 [2900]					
Weight, kg [lb]		12,6 [27.8]	12,7 [28]	13,3 [29.3]	13,4 [29.5]	14 [30.9]	14,1 [31.1]

* Intermittent operation: the permissible values may occur for max. 10% of every minute.

** Peak load: the permissible values may occur for max. 1% of every minute.

*** For speeds lower than given, consult factory or your regional manager.

**** Motor-brakes must always have a drain line. The brake release pressure is the difference between the pressure in the brake release line and the pressure in the drain line.

- Intermittent speed and intermittent pressure must not occur simultaneously.
- Recommended filtration is per ISO cleanliness code 20/16. A nominal filtration of 25 micron or better.
- Recommend using a premium quality, anti-wear type mineral based hydraulic oil HLP(DIN51524) or HM (ISO 6743/4). If using synthetic fluids consult the factory for alternative seal materials.
- Recommended minimum oil viscosity 13 mm²/s [70 SUS] at 50°C [122°F].
- Recommended maximum system operating temperature is 82°C [180°F].
- To assure optimum motor life fill with fluid prior to loading and run at moderate load and speed for 10-15 minutes.

DIMENSIONS AND MOUNTING DATA

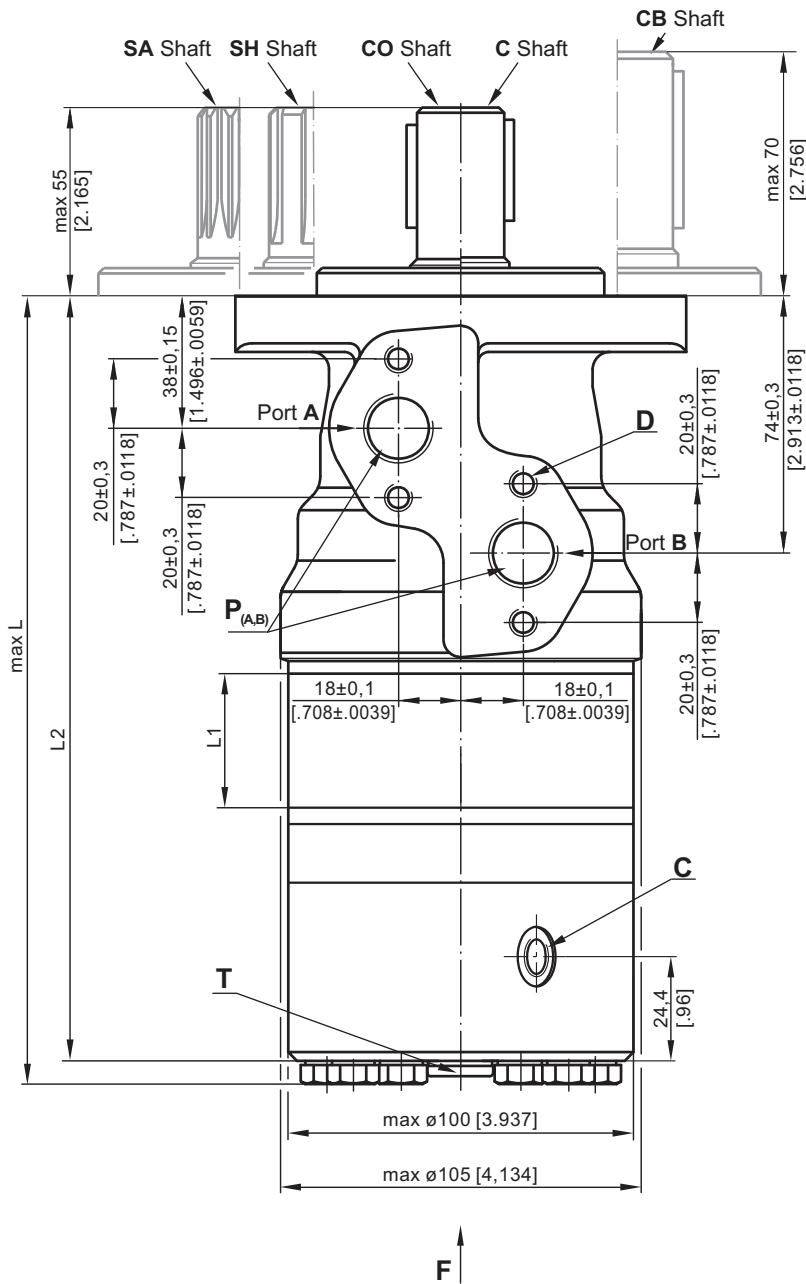

Shaft Dim.
See Page 25

Flange Dim.
See Page 25

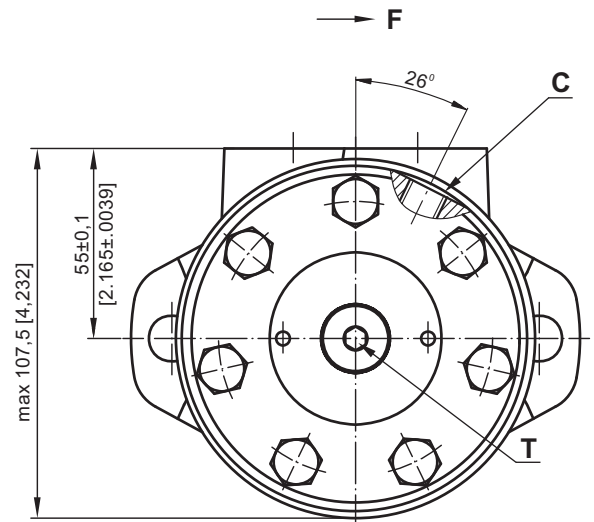

- D** : 4xM8 - 13 mm [.51 in] depth
- C** : G1/4 - 12 [.47 in] mm depth
- P_(A,B)** : 2xG1/2 - 15 [.59 in] mm depth
- T** : G1/4 - 10 mm [.393 in] depth

Type	L1, mm [in]	L2, mm [in]	L, mm [in]
B/MR 80	14,0 [.551]	205,5 [8.091]	213,5 [8.405]
B/MR 100	17,4 [.685]	209,0 [8.228]	217,0 [8.543]
B/MR 125	21,8 [.858]	213,5 [8.405]	221,5 [8.720]
B/MR 160	27,8 [1.095]	219,5 [8.642]	227,5 [8.957]
B/MR 200	34,8 [1.37]	226,5 [8.917]	234,5 [9.232]
B/MR 250	43,5 [1.713]	235,0 [9.252]	243,0 [9.567]
B/MR 315	54,8 [2.157]	246,5 [9.705]	254,5 [10.02]
B/MR 400	69,4 [2.732]	261,0 [10.275]	269,0 [10.59]



Standard Rotation

Viewed from Shaft End
Port A Pressurized - **CW**
Port B Pressurized - **CCW**

Reverse Rotation

Viewed from Shaft End
Port A Pressurized - **CCW**
Port B Pressurized - **CW**

SHAFT EXTENSIONS

C - $\varnothing 25$ straight, Parallel key A8x7x32 DIN 6885
Max. Torque 34 daNm [3010 lb-in]

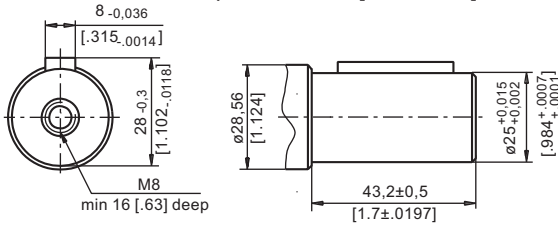

CO - $\varnothing 1$ " straight, Parallel key $\frac{1}{4}$ "x $\frac{1}{4}$ "x $\frac{1}{4}$ " BS46
Max. Torque 34 daNm [3010 lb-in]

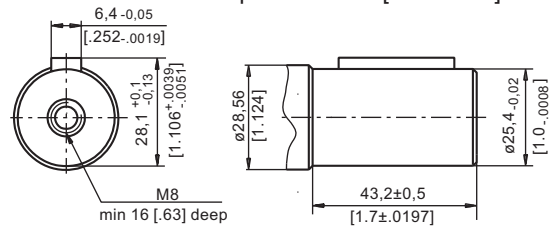

SH - splined, BS 2059 (SAE 6B)
Max. Torque 40 daNm [3540 lb-in]

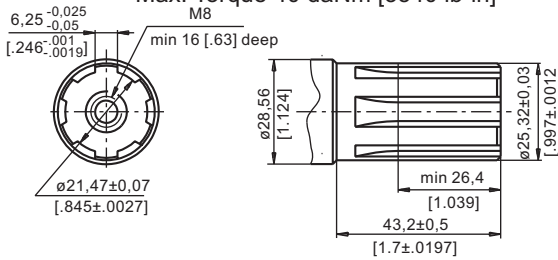

SA - splined, B25x22h9 DIN 5482
Max. Torque 40 daNm [3540 lb-in]

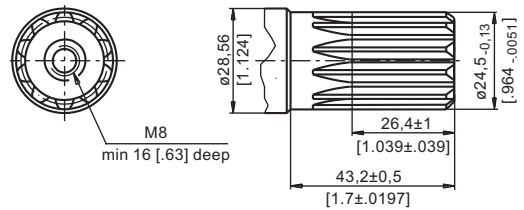

CB - $\varnothing 32$ straight, Parallel key A10x8x45 DIN 6885
Max. Torque 77 daNm [6815 lb-in]

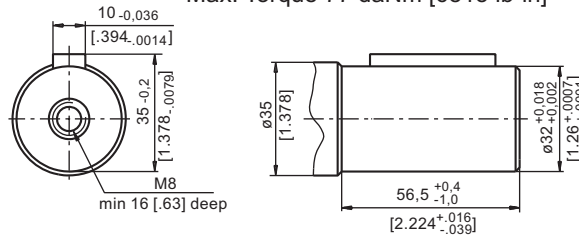

MOUNTING

Oval Mount (2 Holes)

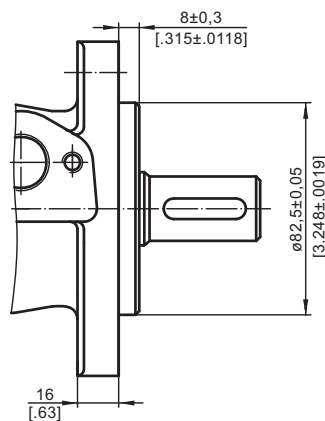
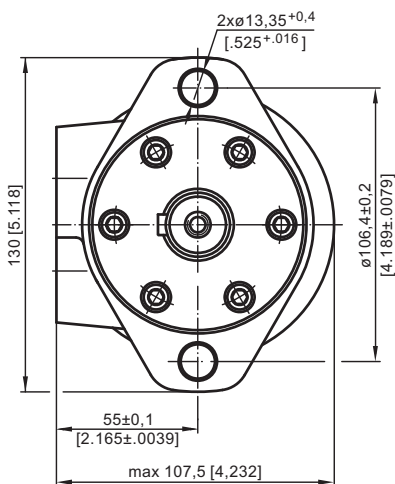

F - Oval Mount (4 Holes)

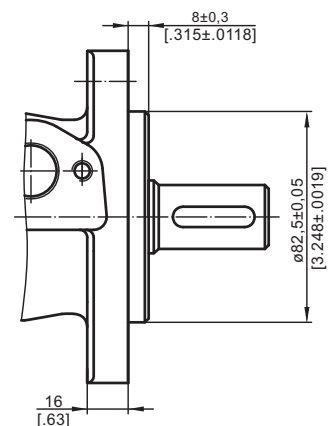
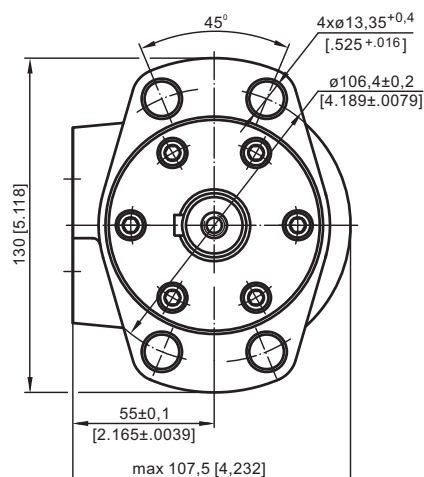

PERMISSIBLE SHAFT LOADS

The permissible radial shaft load P_{rad} depends on the speed n , RPM; distance L from the point of load to the mounting flange and shaft version.

Mounting Flange		
Shaft Version	cylindrical - C, CO splined - SH, SA	cylindrical - CB
Radial Shaft Load P_{rad} , in mm	$\frac{800}{n} \times \frac{25000}{95+L}$, daN*	$\frac{800}{n} \times \frac{18750}{95+L}$, daN*
Radial Shaft Load P_{rad} , in inch	$\frac{800}{RPM} \times \frac{2215}{3.74+L}$, lbs*	$\frac{800}{RPM} \times \frac{1660}{3.74+L}$, lbs*

* $n \leq 200$ RPM; max $P_{rad}=800$ daN [1800 lbs] $n \geq 200$ RPM; $L < 55$ mm [2.2 in]

Radial Shaft Load P_{rad} for C, CO Shaft Extensions by $L=30$ mm [1.18 in]

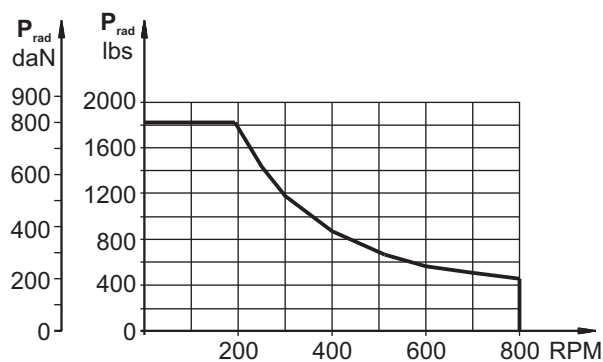
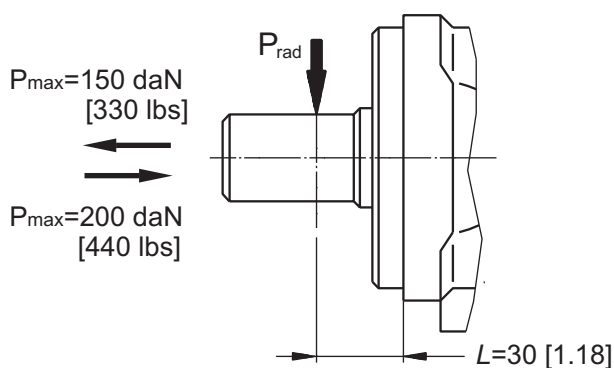

ORDER CODE

1	2	3	4	5
B / M R				

Pos.1 - Mounting Flange

- omit - Oval mount, two holes
- F** - Oval mount, four holes

Pos.2 - Displacement code

- 80** - 80,3 cm³/rev [4.90 in³/rev]
- 100** - 99,8 cm³/rev [6.09 in³/rev]
- 125** - 125,7 cm³/rev [7.67 in³/rev]
- 160** - 159,6 cm³/rev [9.74 in³/rev]
- 200** - 199,8 cm³/rev [12.19 in³/rev]
- 250** - 250,1 cm³/rev [15.26 in³/rev]
- 315** - 315,7 cm³/rev [19.26 in³/rev]
- 400** - 397,0 cm³/rev [24.40 in³/rev]

Pos.3 - Shaft Extensions*

- C** - $\phi 25$ straight, Parallel key A8x7x32 DIN6885
- CO** - $\phi 1$ " straight, Parallel key $\frac{1}{4} \times \frac{1}{4} \times 1 \frac{1}{4}$ " BS46
- SH** - $\phi 25,32$ splined BS 2059 (SAE 6B)
- SA** - $\phi 24,5$ splined B 25x22 DIN 5482
- CB** - $\phi 32$ straight, Parallel key A10x8x45 DIN 6885

Pos.4 - Special Features (see page 68)

Pos.5 - Design Series

- omit - Factory specified

NOTES: * The permissible output torque for shafts must not be exceeded!

The motor-brakes are mangano-phosphatized as standard.