

# Axial piston variable pump AA4VG Series 32

Americas

**RE-A 92003**

Edition: 06.2018

Replaces: 04.2016



- ▶ High-pressure pump for applications in a closed circuit
- ▶ Size 28 to 125
- ▶ Nominal pressure 5800 psi (400 bar)
- ▶ Maximum pressure 6500 psi (450 bar)
- ▶ Closed circuit

## Features

- ▶ Integrated auxiliary pump for boost and pilot oil supply
- ▶ Flow direction changes smoothly when the swashplate is moved through the neutral position
- ▶ High-pressure relief valves with integrated boost function
- ▶ With adjustable pressure cut-off as standard
- ▶ Boost-pressure relief valve
- ▶ Through drive for mounting of further pumps up to same nominal size
- ▶ Large variety of controls
- ▶ Swashplate design

## Contents

Type code	2
Hydraulic fluids	5
Shaft seal	6
Working pressure range	7
Technical data	8
NV – Version without control module	11
DG – Hydraulic control, direct operated	11
HD – Proportional control, hydr., pilot-pressure related	12
HW – Proportional control, hydraulic, mechanical servo	14
EP – Proportional control, electric	16
EZ – Two-point control, electric	18
DA – Automatic control, speed related	19
ET – Electric control, direct operated	22
Dimensions, size 28 to 125	23
Dimensions, through drive	48
Overview of mounting options	51
Combination pumps AA4VG + AA4VG	52
High-pressure relief valves	53
Pressure cut-off	54
Mechanical stroke limiter	54
Stroking chamber pressure port X <sub>3</sub> and X <sub>4</sub>	55
Filtration in the boost pump suction line	56
Filtration in the boost pump pressure line	56
External boost pressure supply	59
Dimensions with filter fitted	60
Swivel angle sensor	61
Connector for solenoids	62
Rotary inch valve	63
Installation dimensions for coupling assembly	64
Installation instructions	65
Project planning notes	68
Safety instructions	68

## Type code

01	02	03	04	05	06	07	08	09	10	11	12	13	14	15	16	17	18	19	20	21	22	
AA4V	G			D				/	32		-	N										

### Axial piston unit

01	Swashplate design, variable, nominal pressure 5800 psi (400 bar), maximum pressure 6500 psi (450 bar)	AA4V
----	---	------

### Operating mode

02	Pump, closed circuit	G
----	----------------------	---

### Size (NG)

03	Geometric displacement, see "Technical data" on page 8	in <sup>3</sup> /rev.	1.71	2.44	3.42	4.33	5.49	7.63
		cm <sup>3</sup> /rev.	28	40	56	71	90	125

### Control device

		28	40	56	71	90	125		
04	Without control module	●	●	●	●	●	●	NV	
	Proportional control, hydraulic	Pilot-pressure related $p = 87$ to 260 psi (6 to 18 bar)	○	○	●	●	●	●	HD3
		Mechanical servo	●	●	●	●	●	●	HW
	Proportional control, electric	$U = 12$ V	●	●	●	●	●	●	EP3
		$U = 24$ V	●	●	●	●	●	●	EP4
	Two-point control, electric	$U = 12$ V	●	●	●	●	●	●	EZ1
		$U = 24$ V	●	●	●	●	●	●	EZ2
	Automatic control, speed related	$U = 12$ V	●	●	●	●	●	●	DA1
		$U = 24$ V	●	●	●	●	●	●	DA2
	Hydraulic control, direct operated		○	○	●	●	●	●	DG
Electric control, direct operated, two pressure reducing valves	$U = 12$ V	●	●	●	●	-	-	ET5	
	$U = 24$ V	●	●	●	●	-	-	ET6	

### Pressure cut-off

05	Pressure cut-off (standard)	D
----	-----------------------------	---

### Neutral position switch

06	Without neutral position switch (without code)	●	
	Neutral position switch (for HW control only)	●	L

### Mechanical stroke limiter

07	Without mechanical stroke limiter (without code)	●	
	Mechanical stroke limiter, externally adjustable	●	M

### Stroking chamber pressure port

		28	40	56	71	90	125	
08	Without stroking chamber pressure port X <sub>3</sub> , X <sub>4</sub> (without code)	●	●	●	●	●	●	
	Stroking chamber pressure port X <sub>3</sub> , X <sub>4</sub>	○	○	●	●	●	●	T

### DA control valve

		NV	HD	HW	DG	DA	EP	EZ		
09	Without DA control valve	●	●	●	●	-	●	●	1	
	DA control valve, fixed setting	-	●	●	●	●	●	-	2	
	DA control valve, mechanically adjustable with position lever	direction of actuation, clockwise	-	●	●	●	●	●	-	3R
		direction of actuation, counter-clockwise	-	●	●	●	●	●	-	3L
	DA control valve, fixed setting, ports for pilot control device	-	○	○	-	○	○	-	7	
	DA control valve, fixed setting and brake inch valve mounted, control with brake fluid based on mineral oil	-	-	-	-	●	-	-	8	

● = Available    ○ = On request    - = Not available     = Preferred program

01	02	03	04	05	06	07	08	09	10	11	12	13	14	15	16	17	18	19	20	21	22	
AA4V	G			D					/	32		-	N									

**Series**

10	Series 3, index 2	32
----	-------------------	----

**Direction of rotation**

11	Viewed on drive shaft	clockwise	R
		counter-clockwise	L

**Sealing material**

12	NBR (nitrile rubber), shaft seal in FKM (fluoroelastomer)	N
----	---	---

**Drive shaft**

			28	40	56	71	90	125	
13	Splined shaft ANSI B92.1a	for single pump	●	●	●	●	●	●	S
		for combination pump – 1st pump	- <sup>1)</sup>	- <sup>1)</sup>	●	●	- <sup>1)</sup>	●	T
		only for combination pump – 2nd pump	-	●	-	-	●	-	U

**Mounting flange**

			28	40	56	71	90	125	
14	SAE J744	2-hole	●	●	●	-	-	-	C
		2+4-hole	-	-	-	●	●	●	F

**Working port**

			28	40	56	71	90	125	
15	SAE working port <b>A</b> and <b>B</b> , top and bottom	Suction port <b>S</b> bottom	-	●	●	●	●	●	52
	SAE working port <b>A</b> and <b>B</b> , top and bottom	Suction port <b>S</b> top	-	○	●	-	-	○	53
	SAE working port <b>A</b> and <b>B</b> , same side right <sup>2)</sup>	Suction port <b>S</b> bottom	●	-	-	-	-	-	60
	SAE working port <b>A</b> and <b>B</b> , same side left <sup>2)</sup>	Suction port <b>S</b> bottom	-	-	-	●	-	-	
	SAE working port <b>A</b> and <b>B</b> , same side right <sup>2)</sup>	Suction port <b>S</b> top	-	-	-	-	-	○	63

**Boost pump**

16	Without integrated boost pump	without through drive	N
		with through drive	K
	Integrated boost pump	with and without through drive	F

**Through drive<sup>3)</sup>**

			28	40	56	71	90	125	
17	Without through drive, versions N and F (no. 16) only		●	●	●	●	●	●	00
	Flange SAE J744 <sup>4)</sup>	Hub for splined shaft							
	82-2 (A)	5/8 in 9T 16/32DP <sup>5)</sup>	●	●	●	●	●	●	01
	101-2 (B)	7/8 in 13T 16/32DP <sup>5)</sup>	●	●	●	●	●	●	02
		1 in 15T 16/32DP <sup>5)</sup>	●	●	●	●	●	●	04
	127-2 (C) <sup>6)</sup>	1 1/4 in 14T 12/24DP <sup>5)</sup>	-	-	●	●	●	●	07
	152-2/4 (D)	1 3/4 in 13T 8/16DP <sup>5)</sup>	-	-	-	-	-	●	69

● = Available    ○ = On request    - = Not available     = Preferred program

1) Standard for combination pump – 1st pump: Shaft S  
2) Only possible without attachment filter  
3) Specifications for version with integrated boost pump, please contact us for version without boost pump

4) 2 = 2-hole; 4 = 4-hole  
5) Hub for splined shaft to ANSI B92.1a  
6) NG90 to 125 with additional 4-hole-flange (127-4)

4 **AA4VG Series 32** | Axial piston variable pump  
Type code

01	02	03	04	05	06	07	08	09	10	11	12	13	14	15	16	17	18	19	20	21	22
AA4V	G			D				/	32		-	N									
<b>High-pressure relief valve</b>												Setting range $\Delta p$		<b>28</b>	<b>40</b>	<b>56</b>	<b>71</b>	<b>90</b>	<b>125</b>		
<b>18</b>	High pressure relief valve, pilot operated										1450 to 6100 psi (100 to 420 bar)	with bypass	-	-	-	●	●	●	<b>1</b>		
	High-pressure relief valve, direct operated, fixed setting										3600 to 6100 psi (250 to 420 bar)	without bypass	●	●	●	-	-	-	<b>3</b>		
												with bypass	●	●	●	-	-	-	<b>5</b>		
											1450 to 3600 bar (100 to 250 bar)	without bypass	●	●	●	-	-	-	<b>4</b>		
												with bypass	●	●	●	-	-	-	<b>6</b>		
<b>Filtration boost circuit/external boost pressure supply</b>												<b>28</b>	<b>40</b>	<b>56</b>	<b>71</b>	<b>90</b>	<b>125</b>				
<b>19</b>	Filtration in the boost pump suction line												●	●	●	●	●	●	<b>S</b>		
	Filtration in the boost pump pressure line												●	●	●	●	●	●	<b>D</b>		
	Ports for external boost circuit filtration ( $F_e$ and $F_a$ )												●	●	●	●	●	●	<b>D</b>		
	Mounted cold start valve and ports for external boost circuit filtration												-	●	●	-	-	-	<b>K</b>		
	Attachment filter with cold start valve												-	●	●	●	●	●	<b>F</b>		
	Attachment filter with cold start valve and visual contamination indicator												-	●	●	●	●	●	<b>P</b>		
	Attachment filter with cold start valve and electric contamination indicator												-	●	●	●	●	●	<b>B</b>		
	External boost pressure supply (version without integrated boost pump - N00, K...)												●	●	●	●	●	●	<b>E</b>		
<b>Swivel angle sensor</b>												<b>28</b>	<b>40</b>	<b>56</b>	<b>71</b>	<b>90</b>	<b>125</b>				
<b>20</b>	Without swivel angle sensor (without code)												●	●	●	●	●	●			
	Electric swivel angle sensor <sup>7)</sup>												○	○	●	○	○	○	<b>R</b>		
<b>Connector for solenoids<sup>8)</sup></b>																					
<b>21</b>	Without connector (without code), only for purely hydraulic control																●				
	DEUTSCH molded connector, 2-pin																●	<b>P</b>			
																	●	<b>Q</b>			
<b>Standard / special version</b>																					
<b>22</b>	Standard version																				
																		<b>-K</b>			
	Special version																	<b>-S</b>			
																		<b>-SK</b>			

● = Available    ○ = On request    - = Not available     = Preferred program

**Notice**

- ▶ Note the project planning notes on page 68.
- ▶ In addition to the type code, please specify the relevant technical data when placing your order.

7) Please contact us if the swivel angle sensor is used for control

8) Connectors for other electric components may deviate

## Hydraulic fluids

The AA4VG variable pump is designed for operation with HLP mineral oil according to DIN 51524.

Application instructions and requirements for hydraulic fluids should be taken from the following data sheets before the start of project planning:

- ▶ 90220: Hydraulic fluids based on mineral oils and related hydrocarbons
- ▶ 90221: Environmentally acceptable hydraulic fluids
- ▶ 90222: Fire-resistant, water-free hydraulic fluids (HFDR/HFDU)
- ▶ 90225: Axial piston units for operation with water-free and water-containing fire-resistant hydraulic fluids (HFDR, HFDU, HFAE, HFAS, HFB, HFC).

### Notes on selection of hydraulic fluid

The hydraulic fluid should be selected such that the operating viscosity in the operating temperature range is within the optimum range ( $\nu_{opt}$  see selection diagram).

### Notice

At no point of the component may the temperature be higher than 240 °F (115 °C). The temperature difference specified in the table is to be taken into account when determining the viscosity in the bearing.

Please contact us if the above conditions cannot be met due to extreme operating parameters.

### Viscosity and temperature of hydraulic fluids

	Viscosity [SUS (mm <sup>2</sup> /s)]	Temperature	Comment
Cold start	$\nu_{max} \leq 7400$ (1600)	$\theta_{St} \geq -40$ °F (-40 °C)	$t \leq 3$ min, $n \leq 1000$ rpm, without load $p \leq 725$ psi (50 bar)
	Permissible temperature difference	$\Delta T \leq 45$ °F (25 K)	between axial piston unit and hydraulic fluid in the system
Warm-up phase	$\nu = 7400$ to 1850 (1600 to 400)	$\theta = -40$ °F to -13 °F (-40 °C to -25 °C)	at $p \leq 0.7 \times p_{nom}$ , $n \leq 0.5 \times n_{nom}$ and $t \leq 15$ min
Continuous operation	$\nu = 1850$ to 60 (400 to 10)		this corresponds, for VG 46 for example, to a temperature range of +41 °F (5 °C) to +185 °F (85 °C) (see selection diagram)
		$\theta = -13$ °F to +230 °F (-25 °C to +110 °C)	measured at port <b>T</b> Observe the permissible temperature range of the shaft seal ( $\Delta T =$ approx. 9 °F (5 K) between bearing/shaft seal and port <b>T</b> )
	$\nu_{opt} = 170$ to 82 (36 to 16)		Range of optimum operating viscosity and efficiency
Short-term operation	$\nu_{min} \geq 49$ (7)		$t < 3$ min, $p < 0.3 \times p_{nom}$

### ▼ Selection diagram

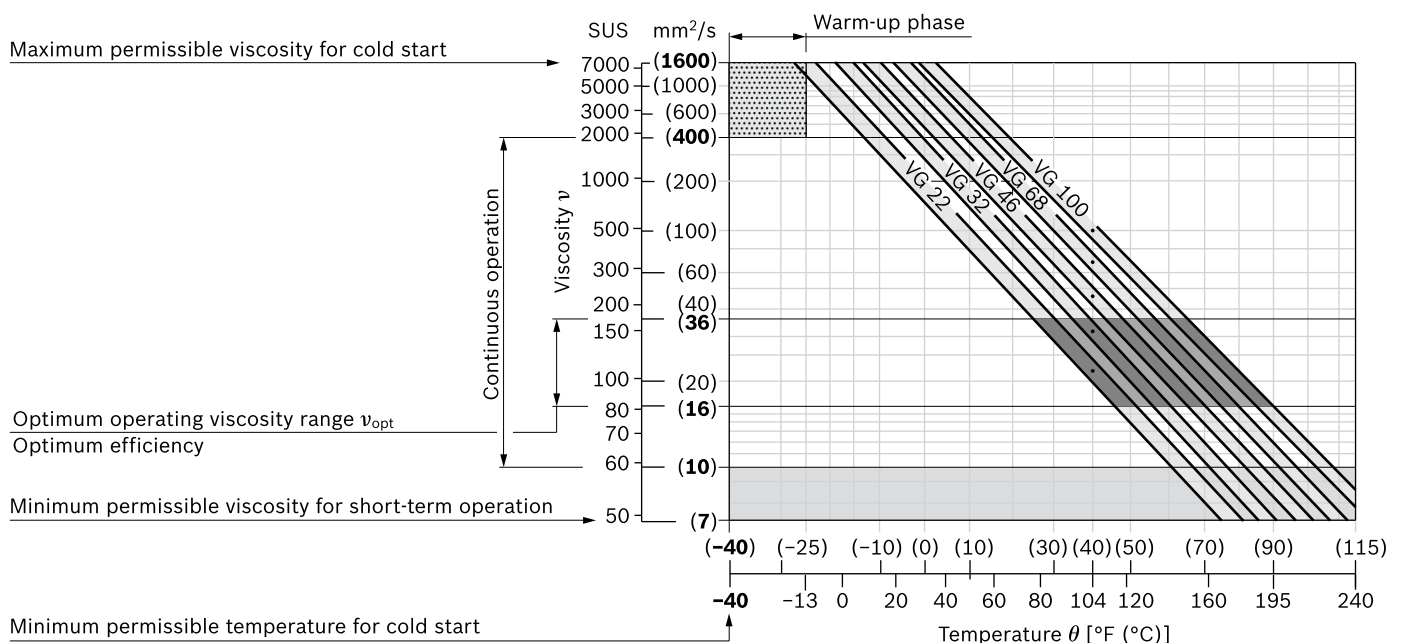

### Filtration of the hydraulic fluid

Finer filtration improves the cleanliness level of the hydraulic fluid, which increases the service life of the axial piston unit.

A cleanliness level of at least 20/18/15 is to be maintained according to ISO 4406.

Depending on the system and the application, for the AA4VG we recommend: Filter elements  $\beta_{20} \geq 100$ .

At very high hydraulic fluid temperatures (194 °F (90 °C) to maximum 230 °F (110 °C), measured at port **T**), a cleanliness level of at least 19/17/14 according to ISO 4406 is necessary.

### Shaft seal

#### Permissible pressure loading

The service life of the shaft seal is influenced by the rotational speed of the axial piston unit and the leakage pressure in the housing (case pressure). Momentary ( $t < 0.1$  s) pressure peaks of up to 145 psi (10 bar) are allowed. The service life of the shaft seal decreases with increasing frequency of pressure peaks and increasing mean differential pressure.

The case pressure must be higher than the ambient pressure.

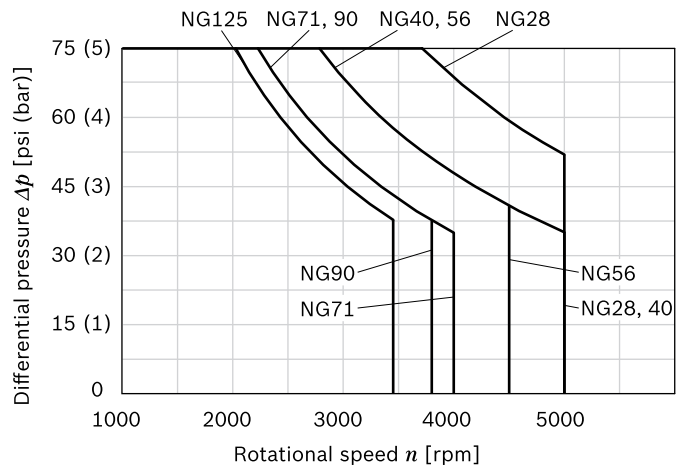

The FKM shaft seal ring may be used for leakage temperatures from -13 °F to +239 °F (-25 °C to +115 °C). For application cases below -13 °F (-25 °C), an NBR shaft seal is required (permissible temperature range: -40 °F to +194 °F (-40 °C to +90 °C)).

## Working pressure range

Pressure at working port A or B		Definition
Nominal pressure $p_{nom}$	5800 psi (400 bar)	The nominal pressure corresponds to the maximum design pressure.
Maximum pressure $p_{max}$	6500 psi (450 bar)	The maximum pressure corresponds to the maximum working pressure within the single operating period. The sum of the single operating periods must not exceed the total operating period.
Single operating period	10 s	
Total operating period	300 h	
Minimum pressure (high-pressure side)	365 psi (25 bar)	Minimum pressure at the high-pressure side (A or B) which is required to prevent damage to the axial piston unit.
Minimum pressure (low-pressure side)	145 psi (10 bar) above case pressure	Minimum pressure at the low-pressure side (A or B) which is required to prevent damage to the axial piston unit.
Rate of pressure change $R_{A max}$	130000 psi/s (9000 bar/s)	Maximum permissible rate of pressure build-up and reduction during a pressure change across the entire pressure range.
Boost pump		
Nominal pressure $p_{Sp nom}$	365 psi (25 bar)	
Maximum pressure $p_{Sp max}$	580 psi (40 bar)	
Pressure at suction port S (inlet)		
Continuous $p_{S min}$ ( $v \leq 140$ SUS) ( $v \leq 30$ mm <sup>2</sup> /s)	$\geq 12$ psi absolute ( $\geq 0.8$ bar absolute)	
Momentary, during cold start ( $t < 3$ min)	$\geq 7.5$ psi (0.5 bar) absolute	
Maximum pressure $p_{S max}$	$\leq 75$ psi (5 bar) absolute	
Control pressure		
Minimum control pressure $p_{St min}$		To ensure the function of the control, a minimum control pressure $p_{St min}$ at $n = 2000$ rpm is necessary depending on the rotational speed and working pressure
Controls EP, HD, HW	290 psi (20 bar) above case pressure	
Controls DA, DG, EZ, ET	365 psi (25 bar) above case pressure	

### ▼ Rate of pressure change $R_{A max}$

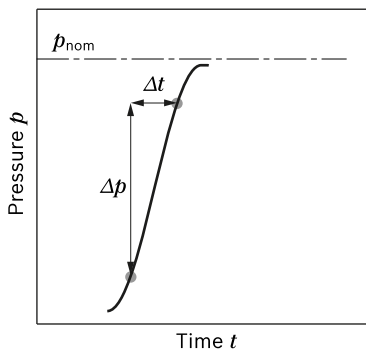

### ▼ Pressure definition

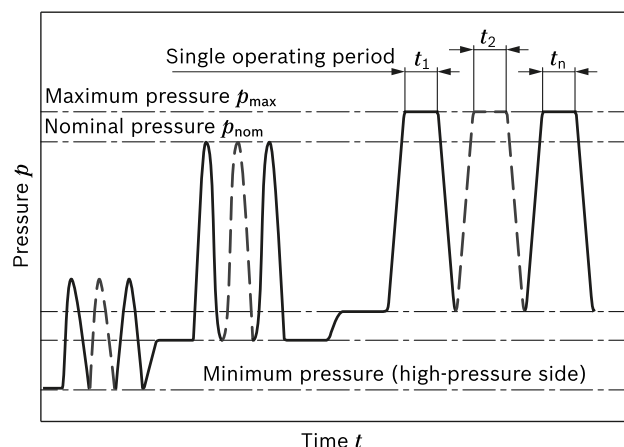

$$\text{Total operating period} = t_1 + t_2 + \dots + t_n$$

#### Notice

Working pressure range valid when using hydraulic fluids based on mineral oils. Please contact us for values for other hydraulic fluids.

## Technical data

Size		NG	28	40	56	71	90	125			
Displacement, geometric, per revolution	$V_{g \max}$	in <sup>3</sup>	1.71	2.44	3.42	4.33	5.49	7.63			
		cm <sup>3</sup>	28	40	56	71	90	125			
	variable pump										
boost pump (at $p = 290$ psi (20 bar))	$V_{g \text{ Sp}}$	in <sup>3</sup>	0.37	0.52	0.71	1.20	1.20	1.73			
		cm <sup>3</sup>	6.1	8.6	11.6	19.6	19.6	28.3			
Rotational speed <sup>1)</sup>	maximum at $V_{g \max}$	$n_{\text{nom}}$	rpm	4250	4000	3600	3300	3050	2850		
	limited, maximum <sup>2)</sup>	$n_{\text{max1}}$	rpm	4500	4200	3900	3600	3300	3250		
	intermittent, maximum <sup>3)</sup>	$n_{\text{max2}}$	rpm	5000	5000	4500	4100	3800	3450		
	minimum	$n_{\text{min}}$	rpm	500	500	500	500	500	500		
Flow	at $n_{\text{nom}}$ and $V_{g \max}$	$q_v$	gpm	31.4	42.3	53.4	61.8	72.6	94		
			l/min	119	160	202	234	275	356		
Power <sup>4)</sup>	at $n_{\text{nom}}$ , $V_{g \max}$ and	$\Delta p = 5800$ psi	$P$	hp	106	143	180	209	245	319	
			$\Delta p = 400$ bar	$P$	kW	79	107	134	156	183	238
Torque <sup>4)</sup>	at $V_{g \max}$ and	$\Delta p = 5800$ psi	$T$	lb-ft	131	188	263	333	423	587	
			$\Delta p = 400$ bar	$T$	Nm	178	255	357	452	573	796
			$\Delta p = 1450$ psi	$T$	lb-ft	33	47	66	83	105	147
			$\Delta p = 100$ bar	$T$	Nm	45	64	89	113	143	199
Rotary stiffness of drive shaft	S	$c$	lb-ft/rad	23159	50892	59595	72871	116609	161010		
			kNm/rad	31.4	69	80.8	98.8	158.1	218.3		
	T	$c$	lb-ft/rad	-	-	70068	89171	-	185939		
			kNm/rad	-	-	95	120.9	-	252.1		
	U	$c$	lb-ft/rad	-	37468	-	-	79362	-		
			kNm/rad	-	50.8	-	-	107.6	-		
Moment of inertia for rotary group		$J_{\text{TW}}$	lbs-ft <sup>2</sup>	0.0522	0.0902	0.1566	0.2302	0.3536	0.5505		
			kgm <sup>2</sup>	0.0022	0.0038	0.0066	0.0097	0.0149	0.0232		
Maximum angular acceleration <sup>5)</sup>		$\alpha$	rad/s <sup>2</sup>	38000	30000	24000	21000	18000	14000		
Case volume		$V$	gal	0.24	0.29	0.40	0.34	0.40	0.55		
			l	0.9	1.1	1.5	1.3	1.5	2.1		
Weight (without through drive) approx.		$m$	lbs	64	68	84	110	132	176		
			kg	29	31	38	50	60	80		

### Notice

- ▶ Theoretical values, without efficiency and tolerances; values rounded
- ▶ Operation above the maximum values or below the minimum values may result in a loss of function, a reduced service life or in the destruction of the axial piston unit. Bosch Rexroth recommend testing the loads by means of experiment or calculation / simulation and comparison with the permissible values.

- The values are applicable:
  - for the optimum viscosity range from  $\nu_{\text{opt}} = 170$  to 82 SUS (36 to 16 mm<sup>2</sup>/s)
  - for hydraulic fluid based on mineral oils (for HF hydraulic fluids, observe the technical data in 90225)
- Valid at half corner power (e.g. at  $V_{g \max}$  and  $p_N/2$ )
- Valid at  $\Delta p = 1000$  to 2200 psi (70 to 150 bar) or  $\Delta p < 4350$  psi (300 bar) and  $t < 0.1$  s
- Without boost pump

### Determining the operating characteristics

$$\text{Flow } q_v = \frac{V_g \times n \times \eta_v}{231} \quad [\text{gpm}] \quad \left( \frac{V_g \times n \times \eta_v}{1000} \right) \quad [\text{l/min}]$$

$$\text{Torque } T = \frac{V_g \times \Delta p}{24 \times \pi \times \eta_{\text{hm}}} \quad [\text{lb-ft}] \quad \left( \frac{V_g \times \Delta p}{24 \times \pi \times \eta_{\text{hm}}} \right) \quad [\text{Nm}]$$

$$\text{Power } P = \frac{2 \pi \times T \times n}{33000} = \frac{q_v \times \Delta p}{1714 \times \eta_t} \quad [\text{HP}] \quad \left( \frac{2 \pi \times T \times n}{60000} = \frac{q_v \times \Delta p \times \eta_t}{600} \right) \quad [\text{kW}]$$

#### Key

- $V_g$  Displacement per revolution [in<sup>3</sup> (cm<sup>3</sup>)]
- $\Delta p$  Differential pressure [psi (bar)]
- $n$  Rotational speed [rpm]
- $\eta_v$  Volumetric efficiency
- $\eta_{\text{mh}}$  Hydraulic-mechanical efficiency
- $\eta_t$  Total efficiency ( $\eta_t = \eta_v \times \eta_{\text{mh}}$ )

- The data are valid for values between the minimum required and maximum permissible rotational speed.  
Valid for external excitation (e.g. diesel engine 2 to 8 times rotary frequency, cardan shaft twice the rotary frequency).  
The limit value is only valid for a single pump.  
The load capacity of the connecting parts must be considered.



**Permissible radial and axial forces on the drive shaft**

▼ **Splined shaft ANSI B92.1a**

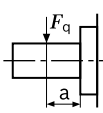
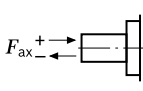
Size	NG	28	40	40	56	56	71			
Drive shaft		in 1	1	1 1/4	1 1/4	1 3/8	1 1/4			
Maximum radial force at distance a (from shaft collar)		$F_{q \max}$	lbf	671	958	766	1073	975	1360	
			N	2983	4261	3409	4772	4338	6050	
			a	in	0.75	0.75	0.94	0.94	0.94	0.94
		mm	19	19	24	24	24	24		
Maximum axial force		$+ F_{ax \max}$	lbf	350	477	477	654	654	954	
			N	1557	2120	2120	2910	2910	4242	
			$- F_{ax \max}$	lbf	94	198	198	355	355	620
			N	417	880	880	1490	1490	2758	

Size	NG	71	90	90	125	125			
Drive shaft		in 1 3/8	1 1/4	1 3/4	1 3/4	2			
Maximum radial force at distance a (from shaft collar)		$F_{q \max}$	lbf	1236	1724	1232	1711	1497	
			N	5500	7670	5478	7609	6658	
			a	in	0.94	0.94	1.32	1.32	1.57
		mm	24	24	33.5	33.5	40		
Maximum axial force		$+ F_{ax \max}$	lbf	954	973	973	1361	1361	
			N	4242	4330	4330	6053	6053	
			$- F_{ax \max}$	lbf	620	600	600	797	797
			N	2758	2670	2670	3547	3547	

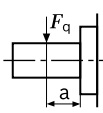
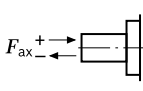
**Notice**

- ▶ The axial and radial forces generally influence the service life of the bearings.
- ▶ Special requirements apply in the case of belt drive and cardan shaft. Please contact us.

**Permissible input and through-drive torques**

Size		NG	28	40	56	71	90	125	
Torque at $V_{g \max}$ and $\Delta p = 5800 \text{ psi}^{1)}$	$T$	lb-ft	131	188	263	333	423	587	
		Nm	178	255	357	452	573	796	
	$T$	Nm	178	255	357	452	573	796	
		lb-ft	131	188	263	333	423	587	
Maximum input torque at drive shaft <sup>2)</sup> ANSI B92.1a (SAE J744)	S	$T_{E \max}$	lb-ft	232	444	444	444	1210	1210
			Nm	314	602	602	602	1640	1640
			in	1	1 1/4	1 1/4	1 1/4	1 3/4	1 3/4
	T	$T_{E \max}$	lb-ft	–	–	715	715	–	1969
			Nm	–	–	970	970	–	2670
			in	–	–	1 3/8	1 3/8	–	2
	U <sup>3)</sup>	$T_{E \max}$	lb-ft	–	232	–	–	444	–
			Nm	–	314	–	–	602	–
			in	–	1	–	–	1 1/4	–
	Maximum through-drive torque <sup>4)</sup>	$T_{D \max}$	lb-ft	170	232	384	487	606	819
			Nm	231	314	521	660	822	1110

**Distribution of torques**

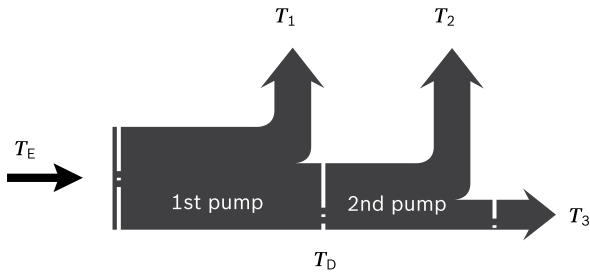

Torque at 1st pump	$T_1$
Torque at 2nd pump	$T_2$
Torque at 3rd pump	$T_3$
Input torque	$T_E = T_1 + T_2 + T_3$
	$T_E < T_{E \max}$
Through-drive torque	$T_D = T_2 + T_3$
	$T_D < T_{D \max}$

- 1) Efficiency not considered
- 2) For drive shafts free of radial force
- 3) Shaft "U" is only permitted as drive shaft on the 2nd pump on a combination pump of the same size.
- 4) Note maximum input torque for shaft S!

## HW – Proportional control, hydraulic, mechanical servo

The output flow of the pump is infinitely variable between 0 and 100%, proportional to the swivel angle of the control lever.

A feedback lever connected to the stroking piston maintains the pump flow for any given position of the control lever. If the pump is also equipped with a DA control valve (see page 19), automotive operation is possible for travel drives.

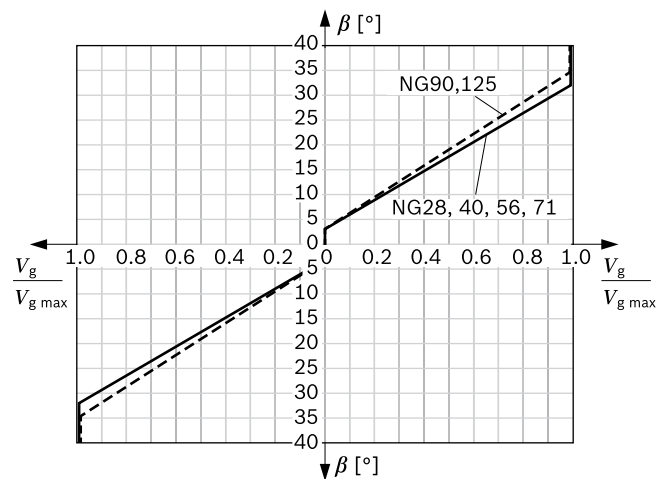

Swivel angle  $\beta$  at the control lever for pump displacement change:

- ▶ Start of control at  $\beta = \pm 3^\circ$
- ▶ End of control at  $\beta$  (max. displacement  $V_{g \max}$ )
  - Size 28 to 71 at  $\pm 32^\circ$
  - Size 90 to 125 at  $\pm 34.5^\circ$
- ▶ Rotational limit  $\beta$  of the control lever (internal)  $\pm 38^\circ$

The maximum required torque at the lever is 15 lb-in (170 Ncm). To prevent damage to the HW control module, a positive mechanical stop of  $36.5^\circ \pm 1$  must be provided for the HW control lever on the customer side.

### Notice

- ▶ Spring centering enables the pump, depending on pressure and speed, to move automatically to the neutral position ( $V_g = 0$ ) as soon as there is no longer any torque on the control lever of the HW control module.
- ▶ If necessary, the position of the lever can be changed. The procedure is defined in the instruction manual.
- ▶ On delivery, the position of the lever may differ from that shown in the drawing.

1) Size 28 without port  $F_{a1}$  and  $F_S$

### Option: Neutral position switch

The switch contact in the neutral position switch is closed when the control lever on the HW control module is in its neutral position. The switch opens when the control lever is moved out of the central position in either direction. Thus, the neutral position switch provides a monitoring function for drive units that require the pump to be in the neutral position during certain operating conditions (e.g. starting diesel engines).

### Technical Data

Load capacity	20 A (continuous), without switching operations
Switching capacity	15 A / 32 V (resistive load) 4 A / 32 V (inductive load)
Connector version	DEUTSCH DT04-2P-EP04 (mating connector, see page 62)

### ▼ Standard version<sup>1)</sup>

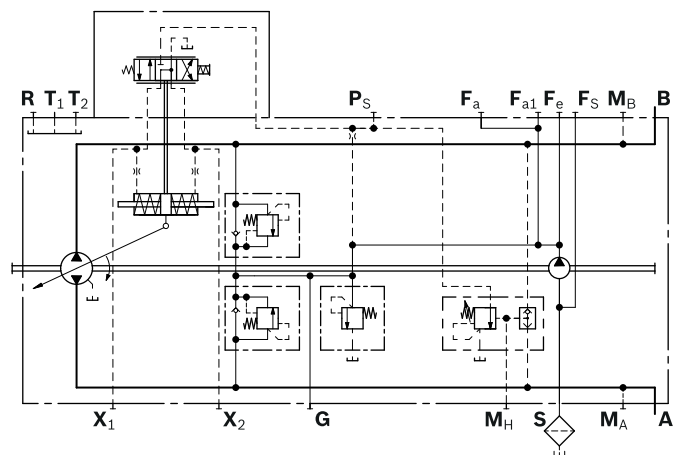

### ▼ Version with DA control valve and neutral position switch<sup>1)</sup>

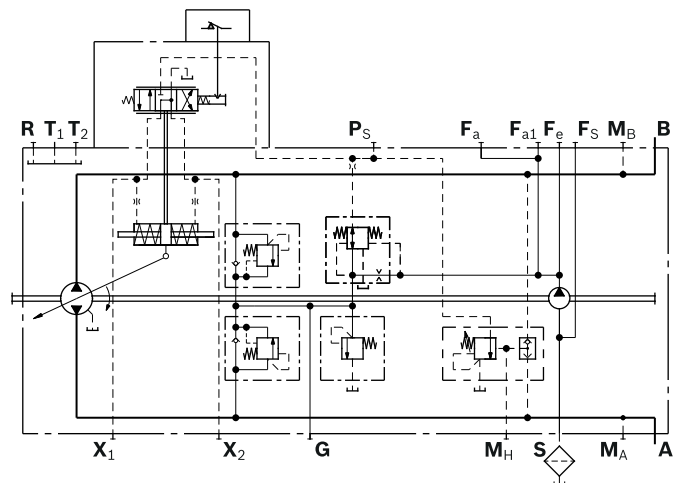

Correlation of direction of rotation, control and flow direction								
Direction of rotation	clockwise				counter-clockwise			
Size	28 to 56		71 to 125		28 to 56		71 to 125	
Lever direction	<b>a</b>	<b>b</b>	<b>a</b>	<b>b</b>	<b>a</b>	<b>b</b>	<b>a</b>	<b>b</b>
Control pressure	<b>X<sub>2</sub></b>	<b>X<sub>1</sub></b>	<b>X<sub>2</sub></b>	<b>X<sub>1</sub></b>	<b>X<sub>2</sub></b>	<b>X<sub>1</sub></b>	<b>X<sub>2</sub></b>	<b>X<sub>1</sub></b>
Flow direction	<b>B to A</b>	<b>A to B</b>	<b>A to B</b>	<b>B to A</b>	<b>A to B</b>	<b>B to A</b>	<b>B to A</b>	<b>A to B</b>
Working pressure	<b>M<sub>A</sub></b>	<b>M<sub>B</sub></b>	<b>M<sub>B</sub></b>	<b>M<sub>A</sub></b>	<b>M<sub>B</sub></b>	<b>M<sub>A</sub></b>	<b>M<sub>A</sub></b>	<b>M<sub>B</sub></b>

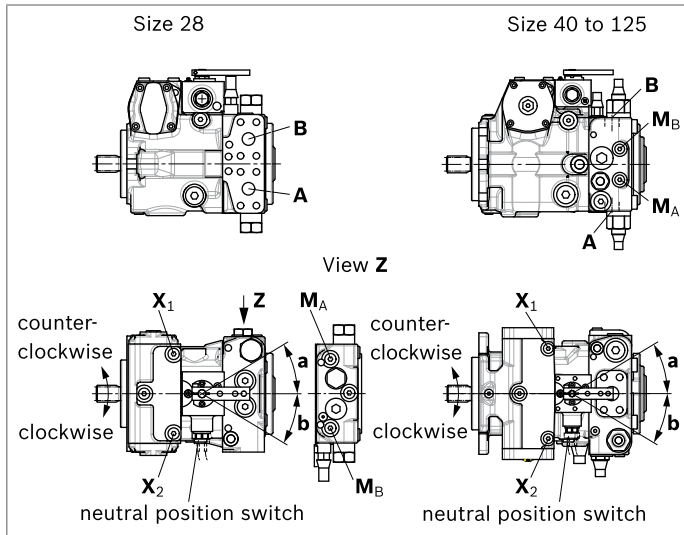

**Dimensions, size 56**

**NV – Version without control module**

Standard: SAE working port **A** and **B** top and bottom, suction port **S** bottom (52)

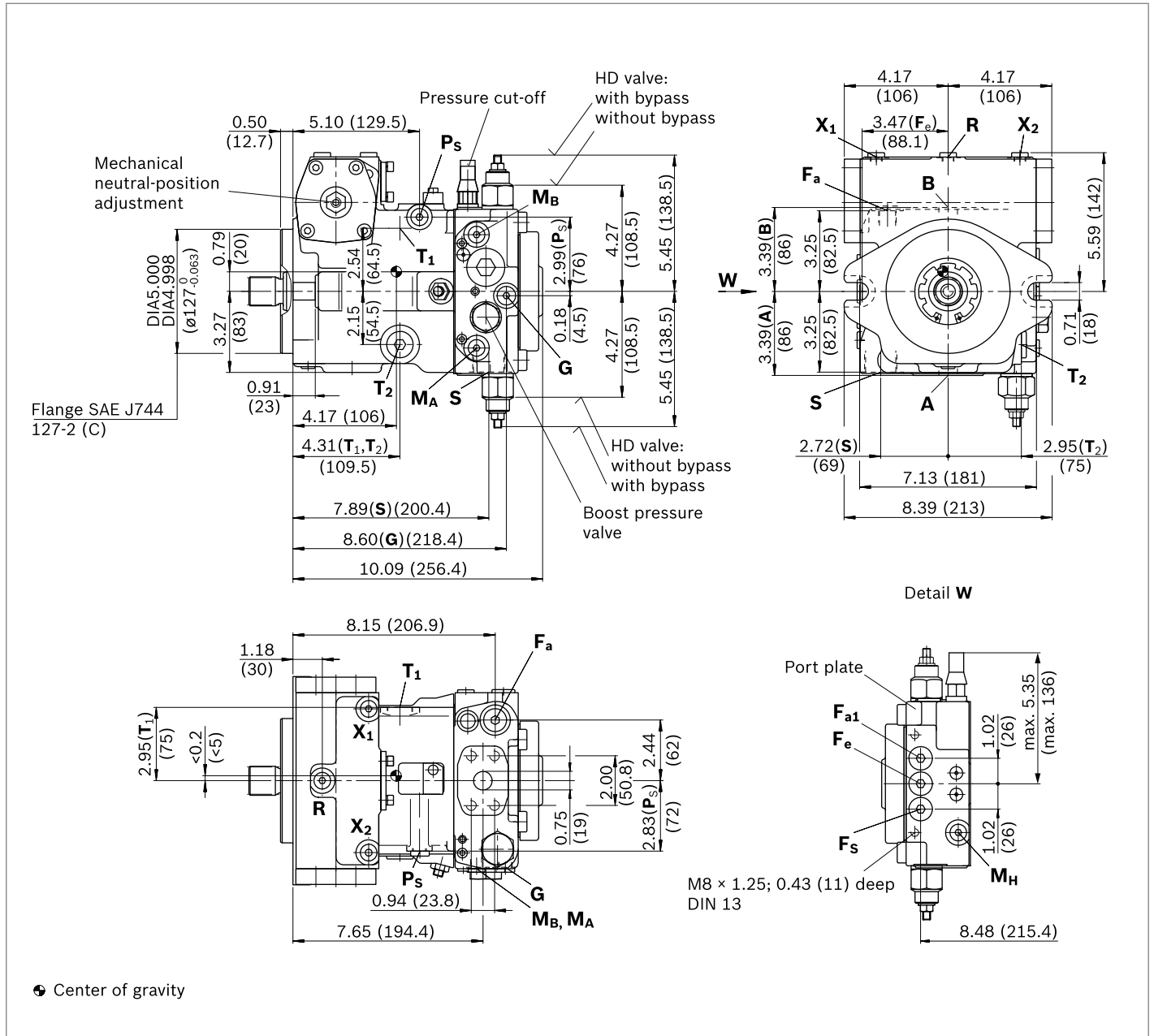

**Notice**

Option: SAE working port **A** and **B** top and bottom, suction port **S** top (53), port plate 52 rotated through 180°, installation drawing on request

▼ **Splined shaft ANSI B92.1a**

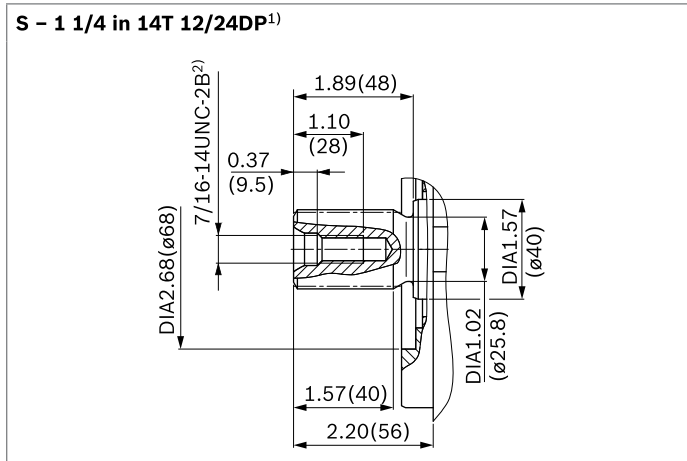

▼ **Splined shaft ANSI B92.1a**

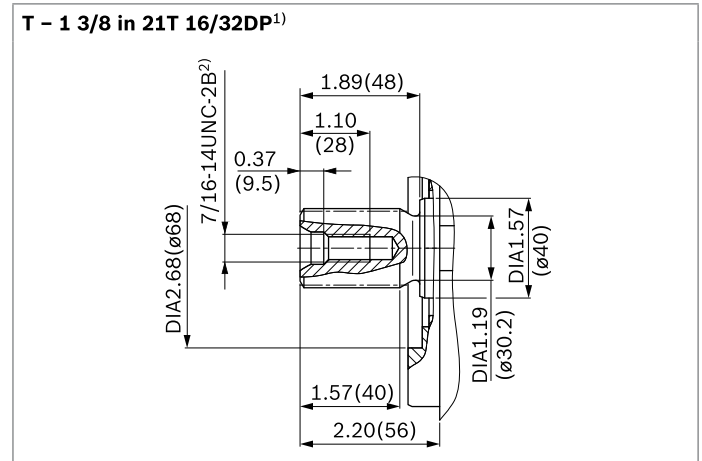

Ports	Standard	Size	$p_{max}$ [psi (bar)] <sup>3)</sup>	State <sup>9)</sup>
<b>A, B</b>	Working port Fastening thread	SAEJ518 <sup>4)</sup> ASME B1.1	3/4 in 3/8 in -16 UNC-2B; 0.67 (17) deep	6500 (450) O
<b>S</b>	Suction port	ISO 11926 <sup>7)</sup>	1 5/16 in -12 UN-2B; 0.79 (20) deep	75 (5) O <sup>5)</sup>
<b>T<sub>1</sub></b>	Drain port	ISO 11926 <sup>7)</sup>	1 1/16 in -12 UN-2B; 0.79 (20) deep	45 (3) O <sup>6)</sup>
<b>T<sub>2</sub></b>	Drain port	ISO 11926 <sup>7)</sup>	1 1/16 in -12 UN-2B; 0.79 (20) deep	45 (3) X <sup>6)</sup>
<b>R</b>	Air bleed port	ISO 11926 <sup>7)</sup>	7/16 in -20 UNF-2B; 0.47 (12) deep	45 (3) X
<b>X<sub>1</sub>, X<sub>2</sub></b>	Control pressure port (upstream of orifice)	ISO 11926 <sup>7)</sup>	7/16 in -20 UNF-2B; 0.47 (12) deep	580 (40) X
<b>X<sub>1</sub>, X<sub>2</sub></b>	Control pressure port (upstream of orifice, DG only)	ISO 11926 <sup>7)</sup>	7/16 in -20 UNF-2B; 0.47 (12) deep	580 (40) O
<b>X<sub>3</sub>, X<sub>4</sub><sup>8)</sup></b>	Stroking chamber pressure port	ISO 11926 <sup>7)</sup>	7/16 in -20 UNF-2B; 0.47 (12) deep	580 (40) X
<b>G</b>	Boost pressure port inlet	ISO 11926 <sup>7)</sup>	9/16 in -18 UNF-2B; 0.51 (13) deep	580 (40) X
<b>P<sub>S</sub></b>	Pilot pressure port	ISO 11926 <sup>7)</sup>	9/16 in -18 UNF-2B; 0.51 (13) deep	580 (40) X
<b>M<sub>A</sub>, M<sub>B</sub></b>	Measuring port pressure A, B	ISO 11926 <sup>7)</sup>	7/16 in -20 UNF-2B; 0.47 (12) deep	6500 (450) X
<b>M<sub>H</sub></b>	Measuring port, high pressure	ISO 11926 <sup>7)</sup>	7/16 in -20 UNF-2B; 0.47 (12) deep	6500 (450) X
<b>F<sub>a</sub></b>	Boost pressure port inlet	ISO 11926 <sup>7)</sup>	3/4 in -16 UNF-2B; 0.59 (15) deep	580 (40) X
<b>F<sub>a1</sub></b>	Boost pressure port inlet (attachment filter)	DIN 3852 <sup>7)</sup>	M18 x 1.5; 0.47 (12) deep	580 (40) X
<b>F<sub>e</sub></b>	Boost pressure port outlet	DIN 3852 <sup>7)</sup>	M18 x 1.5; 0.47 (12) deep	580 (40) X
<b>F<sub>S</sub></b>	Line from filter to suction port (cold start)	DIN 3852 <sup>7)</sup>	M18 x 1.5; 0.47 (12) deep	580 (40) X
<b>Y<sub>1</sub>, Y<sub>2</sub></b>	Pilot pressure port (pilot signal HD only)	ISO 11926 <sup>7)</sup>	9/16 in -18 UNF-2B; 0.51 (13) deep	580 (40) O
<b>Z</b>	Pilot pressure port (inch signal DA..8 only)	DIN 3852 <sup>7)</sup>	M10 x 1; 0.31 (8) deep	580 (40) X

1) Involute spline according to ANSI B92.1a, 30° pressure angle, flat root, side fit, tolerance class 5  
 2) Thread according to ASME B1.1  
 3) Depending on the application, momentary pressure peaks can occur. Keep this in mind when selecting measuring devices and fittings.  
 4) Only dimensions according to SAE J518, metric fastening thread is a deviation from the standard.

5) Plugged for external boost pressure supply.  
 6) Depending on installation position, **T<sub>1</sub>** or **T<sub>2</sub>** must be connected (see also installation instructions on page 65).  
 7) The countersink can be deeper than as specified in the standard.  
 8) Optional, see page 55  
 9) O = Must be connected (plugged when delivered)  
 X = Plugged (in normal operation)

▼ **HD** – Proportional control, hydraulic, pilot-pressure related

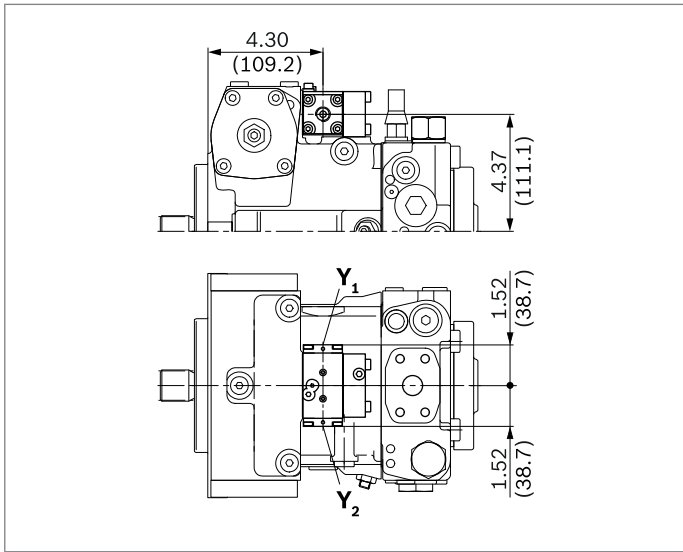

▼ **HW** – Proportional control, hydraulic, mechanical servo

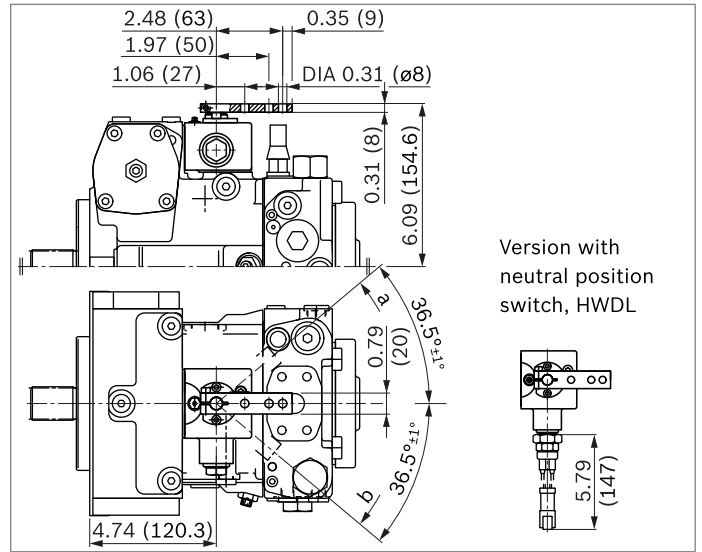

▼ **EP** – Proportional control, electric

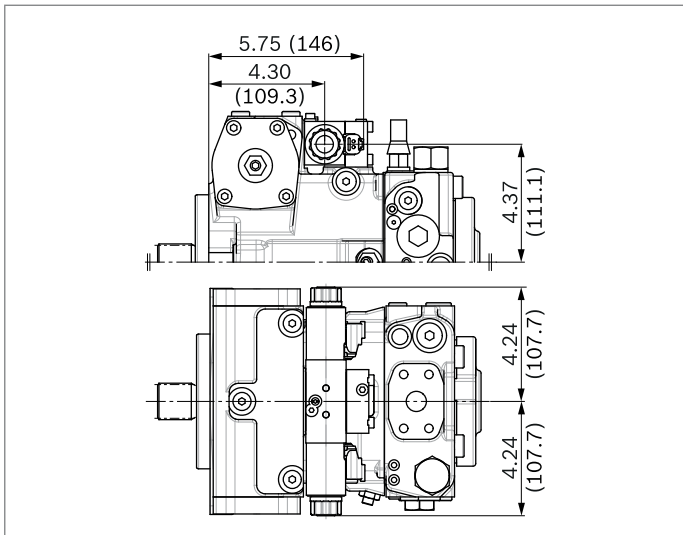

▼ **EZ** – Two-point control, electric

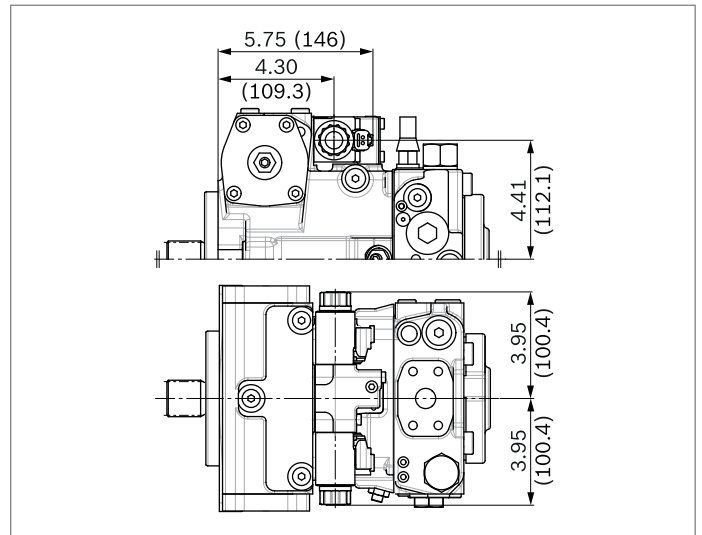

▼ **DG** – Hydraulic control, direct operated

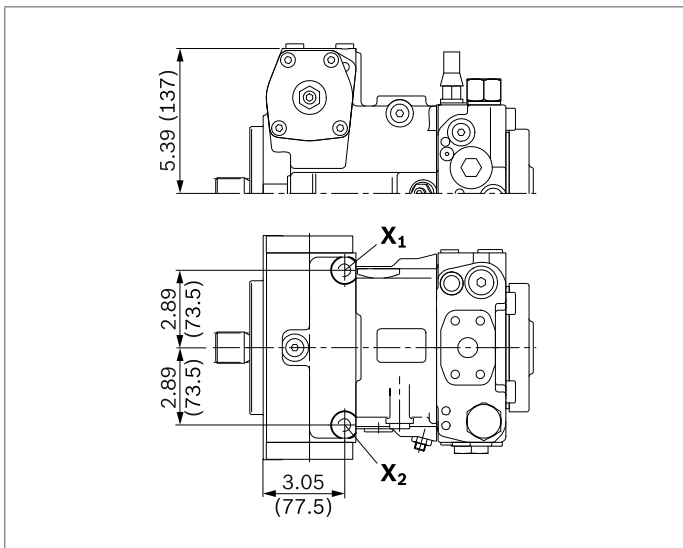

**DA control valve**

▼ **DA..2** – Fixed setting

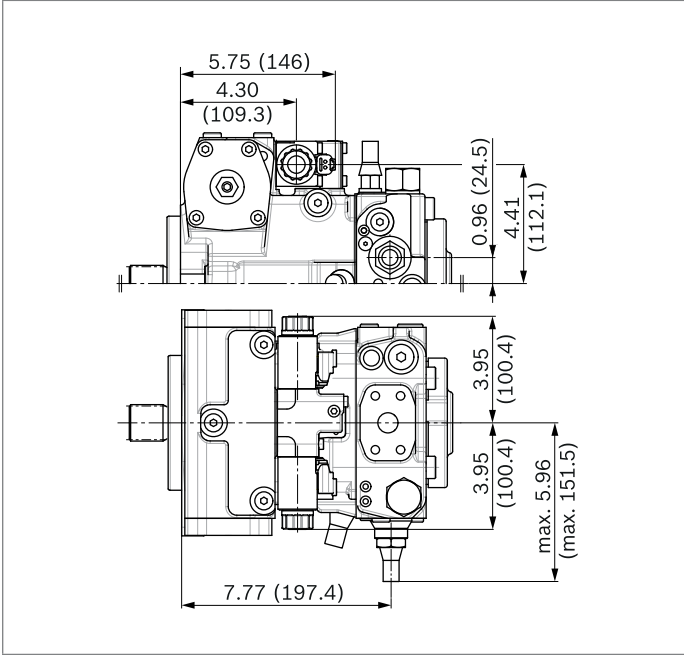

▼ **DA..3** – Mechanically adjustable with position lever

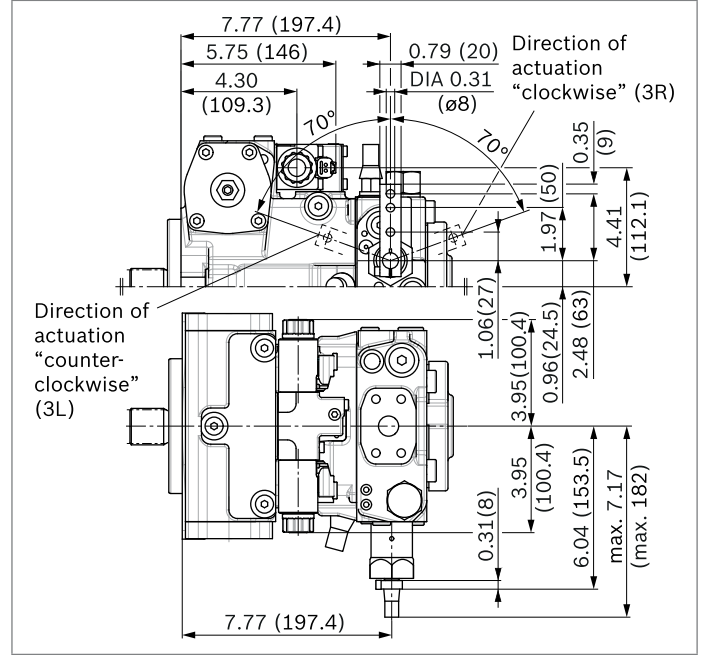

▼ **DA..8** – Fixed setting and inch valve mounted

