

Hydraulic Pumps T6CM for low pressure drives

Denison Vane Technology



ENGINEERING YOUR SUCCESS.

Main Technical Data

T6CM, Denison Vane Pumps

Key features

These hydraulic vane pumps are using the Denison 3 springs technology which has been proven to be very well adapted to pumping at very low system pressure even fluids with high viscosity.

Reliable performance

The Denison Vane Technology allows very low noise levels over the entire operating range and during the whole life of the pump. Like all our vane pumps, the performances do remain very stable over time, making this pump an ideal solution for the heavy duty industries.

Long lifetime

The fully pressure balanced concept increases the pump lifetime over its full operating range while double lip vanes reduce the sensitivity to fluid pollution.

General characteristics

	Mounting standard	Weight without connector and bracket - kg	Moment of inertia kgm ² x 10 ⁻⁴	SAE 4 bolts J518c - ISO/DIS 6162-1	
				Suction	Pressure
T6CM T6CMY	SAE J744c ISO/3019-1 SAE B	15,7	7,5	1.1/2"	1"

Main technical data

Pump		Theoretical Displacement Vi cm ³ /rev.	Max. Speed Mineral oil rpm	Max. Pressure		Minimum allowable inlet pressure (bar absolute)					Ring size
Type	Ring size			Int. bar	Cont. bar	Speed rpm					
						1200	1500	1800	2100	2200	
T6CM T6CMY	R03	10,8	2200	140	110	0,80	0,80	0,80	0,80	0,80	R03
	R05	17,2									R05
	R06	21,3									R06
	R08	26,4									R08
	R10	34,1									R10
	R12	37,1									R12
	R14	46,0									R14
	R17	58,3									R17
	R20	63,8									R20
	R22	70,3									R22
	R25	79,3									R25
	R28	88,8									R28
	R31	100,0									R31

Inlet pressure is measured at inlet flange with petroleum base fluids at viscosity between 10 and 65 cSt. The difference between inlet pressure at the pump flange and atmospheric pressure must not exceed 0.2 bar to prevent aeration.

Multiply absolute pressure by 1,25 for HF-3, HF-4 fluids.
by 1,35 for HF-5 fluid.
by 1,10 for ester or rapeseed base.

Note : For further information or if the performance characteristics outlined in the table do not meet your particular requirements, please consult your local Parker office.



Ordering Code & Dimensions

Hydraulic Pumps for low pressure drives T6CM, Denison Vane Pumps

Model No.

T6CM (Y) - R22 - 1 R 00 - C 1 - ..

T6CM series - SAE B 2 bolts

J744 mounting flange

Y = Port flanges with metric threads

Displacement

Volumetric displacement (cm³/rev.)

R03 = 10,8	R17 = 58,3
R05 = 17,2	R20 = 63,8
R06 = 21,3	R22 = 70,3
R08 = 26,4	R25 = 79,3
R10 = 34,1	R28 = 88,8
R12 = 37,1	R31 = 100,0
R14 = 46,0	

Type of shaft

1 = keyed (SAE B)

2 = keyed (non SAE)

3 = splined (SAE B) 13 teeth

4 = splined (SAE BB) 15 teeth

Modifications

Seal class

1 = S1 (for mineral oil)

4 = S4 (for the resistant fluids)

5 = S5 (for mineral oil and fire resistant fluids)

Design letter

Porting combination

00 = standard

Direction of rotation (shaft end view)

R = Clockwise

L = Counter-clockwise

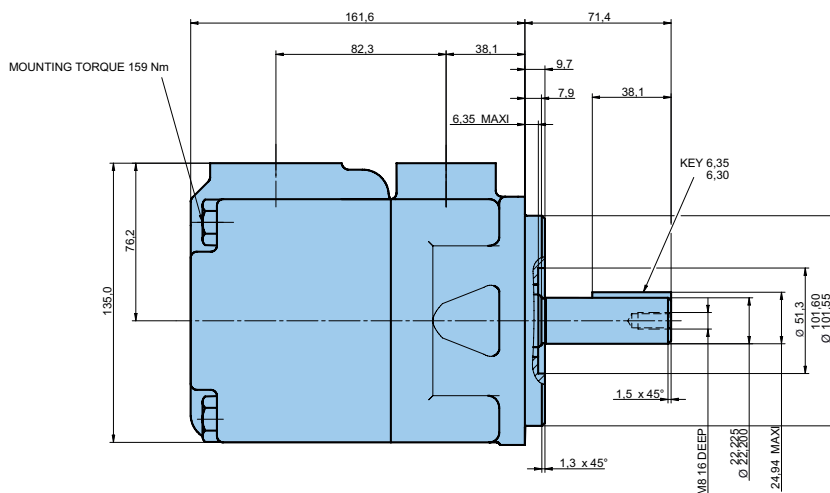
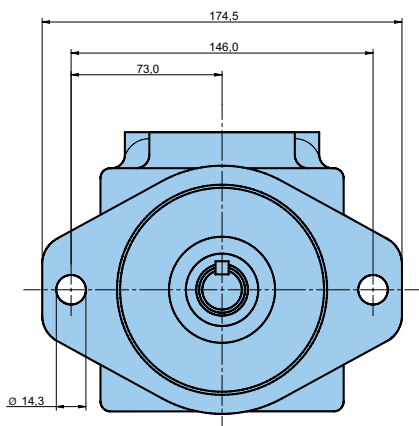
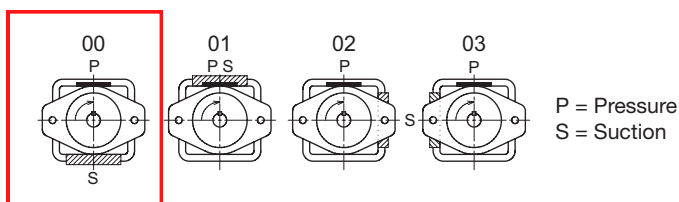

SHAFT CODE 1

(KEYED SAE B)

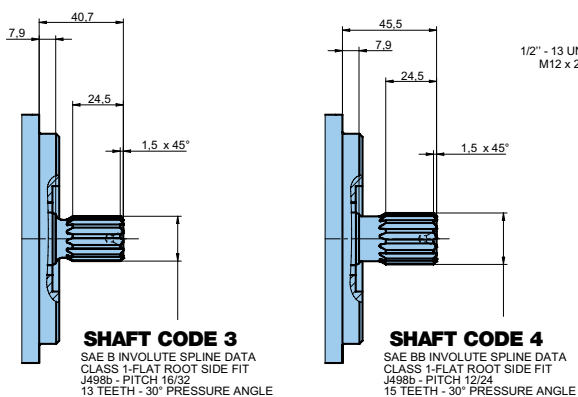

SHAFT CODE 3

SAE B INVOLUTE SPLINE DATA
CLASS 1-FLAT ROOT SIDE FIT
J498b - PITCH 16/32
13 TEETH - 30° PRESSURE ANGLE

SHAFT CODE 4

SAE BB INVOLUTE SPLINE DATA
CLASS 1-FLAT ROOT SIDE FIT
J498b - PITCH 12/24
15 TEETH - 30° PRESSURE ANGLE

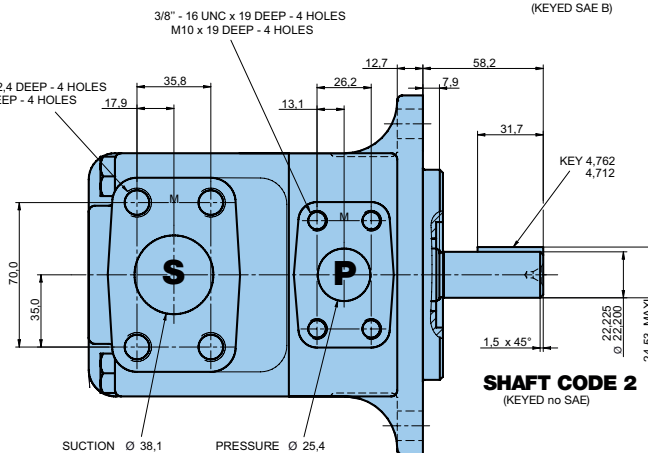

SHAFT CODE 2

(KEYED no SAE)

Internal leakage (Typical)

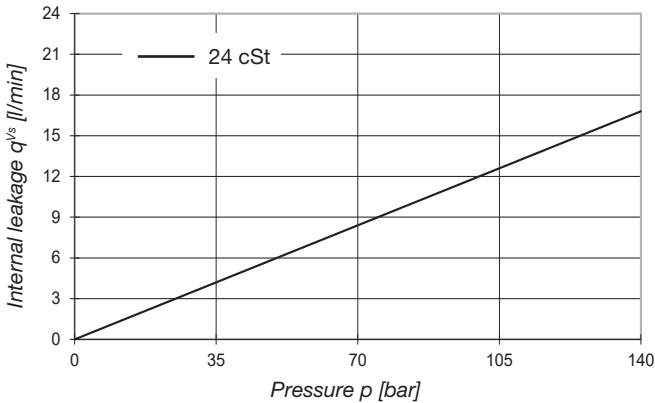

Do not operate pump more than 5 seconds at any speed or viscosity if internal leakage is higher than 50% of theoretical flow.

**Noise level (Typical)
T6CM - R22**

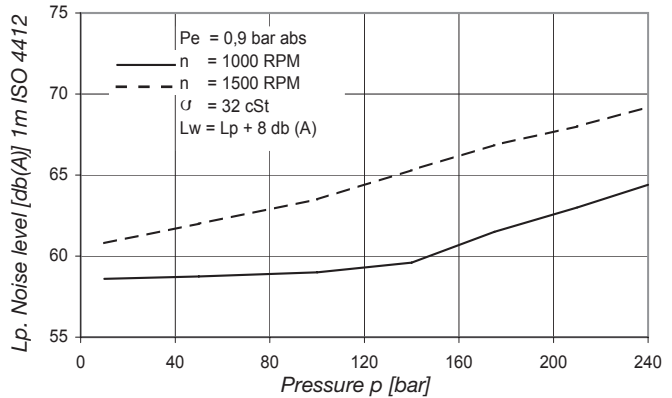

Power loss hydromechanical (Typical)

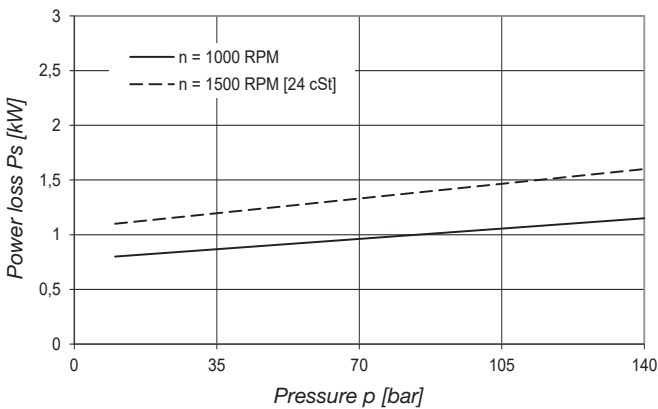

Permissible radial load

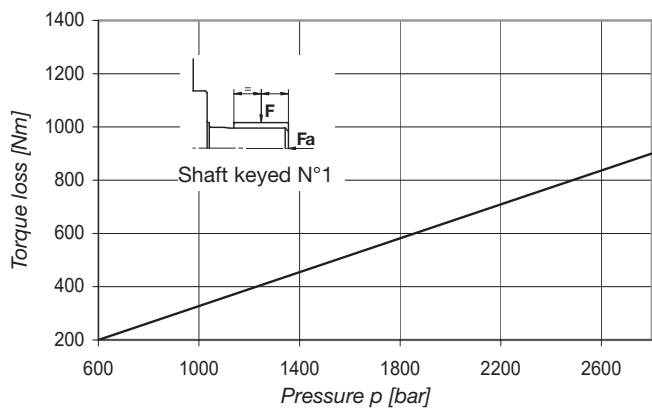

Max permissible axial load Fa = 800 N

Operating characteristics - typical [24 cst]

Pressure port	Series	Vi Volumetric displacement	Output flow q _{vs} [l/min] @ 1500 RPM			Input power P [kW] @ 1500 RPM		
			p = 0 bar	p = 50 bar	p = 140 bar	p = 7 bar	p = 50 bar	p = 140 bar
T6CM T6CMY	R03	10,8 cm ³ /rev	16,2	10,2	¹⁾	1,3	2,7	¹⁾
	R05	17,2 cm ³ /rev	25,8	19,8	¹⁾	1,4	3,0	¹⁾
	R06	21,3 cm ³ /rev	31,9	25,9	¹⁾	1,5	4,0	¹⁾
	R08	26,4 cm ³ /rev	39,6	33,6	22,8	1,6	4,6	11,0
	R10	34,1 cm ³ /rev	51,1	45,1	28,3	1,7	5,6	13,7
	R12	37,1 cm ³ /rev	55,6	49,6	32,8	1,8	6,0	14,7
	R14	46,0 cm ³ /rev	69,0	63,0	52,2	2,0	7,1	17,9
	R17	58,3 cm ³ /rev	87,4	81,5	70,7	2,2	8,6	22,2
	R20	63,8 cm ³ /rev	95,7	89,7	78,9	2,3	9,3	24,1
	R22	70,3 cm ³ /rev	105,4	99,5	88,7	2,4	10,1	26,1
	R25	79,3 cm ³ /rev	118,9	113,0	102,2	2,5	11,2	29,6
	R28	88,8 cm ³ /rev	133,2	127,2	116,4	2,8	12,4	32,9
	R31	100,0 cm ³ /rev	150,0	144	139,2	2,9	13,8	31

¹⁾ Do not use : η vol < 50 %

²⁾ p max = 90 bar

Pump Selection

Calculation

To resolve

Volumetric displ. _____ V_i [cm³/rev.]
 Available flow _____ Q_{eff} [l/min]
 Input power _____ P_{eff} [kW]

Performances required

Requested flow _____ Q [l/min] 42
 Speed _____ n [rpm] 1500
 Pressure _____ p [bar] 50

Routine :

1. First calculation $V_i = 1000 \times Q / n$

2. Choose the pump with the next higher V_i

3. Theoretical flow of this pump

$$Q_{theo} = V_i \times n / 1000$$

4. Read q_{vs} leakage function of pressure $Q_{vs} = f(p)$ on curve

5. Available flow $Q_{eff} = Q_{theo} - q_{vs}$

6. Theoretical input power

$$P_{theo} = Q_{theo} \times p / 600$$

7. Read P_s hydrodynamical power loss on curve

8. Calculation of necessary input power

$$P_{eff} = P_{theo} + P_s$$

9. Results

Example :

$$V_i = 1000 \times 42 / 1500 = 28 \text{ cm}^3/\text{rev.}$$

$$R10, V_i = 34,1 \text{ cm}^3/\text{rev.}$$

$$Q_{theo} = 34,1 \times 1500 / 1000 = 51,1 \text{ l/min}$$

$$q_{vs} = 6 \text{ l/min at 50 bar}$$

$$Q_{eff} = 51,1 - 6 = 45,1 \text{ l/min}$$

$$P_{theo} = 51,1 \times 50 / 600 = 4,3 \text{ kW}$$

$$P_s \text{ at 1500 rpm, 50 bar} = 1,3 \text{ kW}$$

$$P_{eff} = 4,3 + 1,3 = 5,6 \text{ kW}$$

$$V_i = 34,1 \text{ cm}^3/\text{rev.}$$

$$Q_{seff} = 45,1 \text{ l/min}$$

$$P_{eff} = 5,6 \text{ kW}$$

T6CM(Y) R10

Follow these calculation steps for each application.

General applications instructions

1. Check speed range, pressure, temperature, fluid quality, fluid viscosity and pump rotation way.
2. Check the inlet conditions of the pump, if it can accept the application requirements.
3. Check the type of shaft : if it will support the operating torque.
4. Check the coupling which must be chosen to minimize pump shaft load (weight, misalignment).
5. Filtration : must be adequate for the lowest contamination level.
6. Check the environment of the pump : as to avoid noise reflection, pollution and shocks.



WARNING – USER RESPONSIBILITY

FAILURE OR IMPROPER SELECTION OR IMPROPER USE OF THE PRODUCTS DESCRIBED HEREIN OR RELATED ITEMS CAN CAUSE DEATH, PERSONAL INJURY AND PROPERTY DAMAGE.

This document and other information from Parker-Hannifin Corporation, its subsidiaries and authorized distributors provide product or system options for further investigation by users having technical expertise.

The user, through its own analysis and testing, is solely responsible for making the final selection of the system and components and assuring that all performance, endurance, maintenance, safety and warning requirements of the application are met. The user must analyze all aspects of the application, follow applicable industry standards, and follow the information concerning the product in the current product catalog and in any other materials provided from Parker or its subsidiaries or authorized distributors.

To the extent that Parker or its subsidiaries or authorized distributors provide component or system options based upon data or specifications provided by the user, the user is responsible for determining that such data and specifications are suitable and sufficient for all applications and reasonably foreseeable uses of the components or systems.

Offer of Sale

Please contact your Parker representation for a detailed "Offer of Sale".

Parker Worldwide

Europe, Middle East, Africa

AE – United Arab Emirates,
Dubai

Tel: +971 4 8127100
parker.me@parker.com

AT – Austria, Wiener Neustadt
Tel: +43 (0)2622 23501-0
parker.austria@parker.com

AT – Eastern Europe, Wiener
Neustadt
Tel: +43 (0)2622 23501 900
parker.easteurope@parker.com

AZ – Azerbaijan, Baku
Tel: +994 50 22 33 458
parker.azerbaijan@parker.com

BE/LU – Belgium, Nivelles
Tel: +32 (0)67 280 900
parker.belgium@parker.com

BG – Bulgaria, Sofia
Tel: +359 2 980 1344
parker.bulgaria@parker.com

BY – Belarus, Minsk
Tel: +48 (0)22 573 24 00
parker.poland@parker.com

CH – Switzerland, Etoy
Tel: +41 (0)21 821 87 00
parker.switzerland@parker.com

CZ – Czech Republic, Klecany
Tel: +420 284 083 111
parker.czechrepublic@parker.com

DE – Germany, Kaarst
Tel: +49 (0)2131 4016 0
parker.germany@parker.com

DK – Denmark, Ballerup
Tel: +45 43 56 04 00
parker.denmark@parker.com

ES – Spain, Madrid
Tel: +34 902 330 001
parker.spain@parker.com

FI – Finland, Vantaa
Tel: +358 (0)20 753 2500
parker.finland@parker.com

FR – France, Contamine s/Arve
Tel: +33 (0)4 50 25 80 25
parker.france@parker.com

GR – Greece, Athens
Tel: +30 210 933 6450
parker.greece@parker.com

HU – Hungary, Budaörs
Tel: +36 23 885 470
parker.hungary@parker.com

IE – Ireland, Dublin
Tel: +353 (0)1 466 6370
parker.ireland@parker.com

IT – Italy, Corsico (MI)
Tel: +39 02 45 19 21
parker.italy@parker.com

KZ – Kazakhstan, Almaty
Tel: +7 7273 561 000
parker.easteurope@parker.com

NL – The Netherlands, Oldenzaal
Tel: +31 (0)541 585 000
parker.nl@parker.com

NO – Norway, Asker
Tel: +47 66 75 34 00
parker.norway@parker.com

PL – Poland, Warsaw
Tel: +48 (0)22 573 24 00
parker.poland@parker.com

PT – Portugal
Tel: +351 22 999 7360
parker.portugal@parker.com

RO – Romania, Bucharest
Tel: +40 21 252 1382
parker.romania@parker.com

RU – Russia, Moscow
Tel: +7 495 645-2156
parker.russia@parker.com

SE – Sweden, Spånga
Tel: +46 (0)8 59 79 50 00
parker.sweden@parker.com

SK – Slovakia, Banská Bystrica
Tel: +421 484 162 252
parker.slovakia@parker.com

SL – Slovenia, Novo Mesto
Tel: +386 7 337 6650
parker.slovenia@parker.com

TR – Turkey, Istanbul
Tel: +90 216 4997081
parker.turkey@parker.com

UA – Ukraine, Kiev
Tel: +48 (0)22 573 24 00
parker.poland@parker.com

UK – United Kingdom, Warwick
Tel: +44 (0)1926 317 878
parker.uk@parker.com

ZA – South Africa, Kempton Park
Tel: +27 (0)11 961 0700
parker.southafrica@parker.com

North America

CA – Canada, Milton, Ontario
Tel: +1 905 693 3000

US – USA, Cleveland
(industrial)
Tel: +1 216 896 3000

US – USA, Elk Grove Village
(mobile)
Tel: +1 847 258 6200

Asia Pacific

AU – Australia, Castle Hill
Tel: +61 (0)2-9634 7777

CN – China, Shanghai
Tel: +86 21 2899 5000

HK – Hong Kong
Tel: +852 2428 8008

ID – Indonesia, Tangerang
Tel: +62 21 7588 1906

IN – India, Mumbai
Tel: +91 22 6513 7081-85

JP – Japan, Fujisawa
Tel: +81 (0)4 6635 3050

KR – South Korea, Seoul
Tel: +82 2 559 0400

MY – Malaysia, Shah Alam
Tel: +60 3 7849 0800

NZ – New Zealand, Mt Wellington
Tel: +64 9 574 1744

SG – Singapore
Tel: +65 6887 6300

TH – Thailand, Bangkok
Tel: +662 186 7000

TW – Taiwan, New Taipei City
Tel: +886 2 2298 8987

VN – Vietnam, Ho Chi Minh City
Tel: +84 8 3999 1600

South America

AR – Argentina, Buenos Aires
Tel: +54 3327 44 4129

BR – Brazil, Cachoeirinha RS
Tel: +55 51 3470 9144

CL – Chile, Santiago
Tel: +56 2 623 1216

MX – Mexico, Toluca
Tel: +52 72 2275 4200

EMEA Product Information Centre

Free phone: 00 800 27 27 5374

(from AT, BE, CH, CZ, DE, DK, EE, ES, FI, FR, IE, IL,
IS, IT, LU, MT, NL, NO, PL, PT, RU, SE, SK, UK, ZA)

US Product Information Centre

Toll-free number: 1-800-27 27 537

www.parker.com

