

### General Description

Pilot Operated Spool-Type Relief Valve.  
 For additional information see  
 Technical Tips on pages PC1-PC6.



### Features

- Hardened, precision ground parts for durability
- Low profile adapter for minimal space requirements
- Fully guided pilot for more consistent reseal
- Steel adapters are zinc plated
- Polyurethane “D”-Ring eliminates backup rings and prevents hydrolysis
- Internal screening protects pilot spring from debris

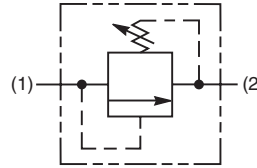
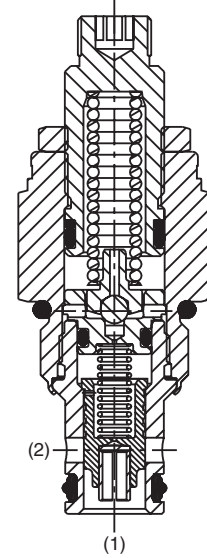

### Specifications

Rated Flow	75.8 LPM (20 GPM)
Maximum Inlet Pressure	350 Bar (5000 PSI)
Maximum Pressure Setting	350 Bar (5000 PSI)
Sensitivity: Pressure/Turn	<b>10</b> 19.6 Bar (285 PSI) <b>30</b> 58.9 Bar (859 PSI) <b>50</b> 131.7 Bar (1910 PSI)
Maximum Tank Pressure	350 Bar (5000 PSI)
Reseat Pressure	90% of crack pressure
Leakage at 150 SSU (32 cSt)	5 cc per 6.8 Bar (100PSI) setting
Cartridge Material	All parts steel. All operating parts hardened steel.
Operating Temp. Range/Seals	-37°C to +93°C (“D”-Ring) -35°F to +200°F -34°C to +121°C (Nitrile) (-30°F to +250°F) -26°C to +204°C (Fluorocarbon) (-15°F to +400°F)
Fluid Compatibility/Viscosity	Mineral-based or synthetic with lubricating properties at viscosities of 45 to 2000 SSU (6 to 420 cSt)
Filtration	ISO-4406 18/16/13, SAE Class 4
Approx. Weight	0.09 kg (0.20 lbs.)
Cavity	C08-2 (See BC Section for more details)
Form Tool	Rougher None Finisher NFT08-2F

### Performance Curves

#### Flow vs. Inlet Pressure

(Pressure rise through cartridge only)

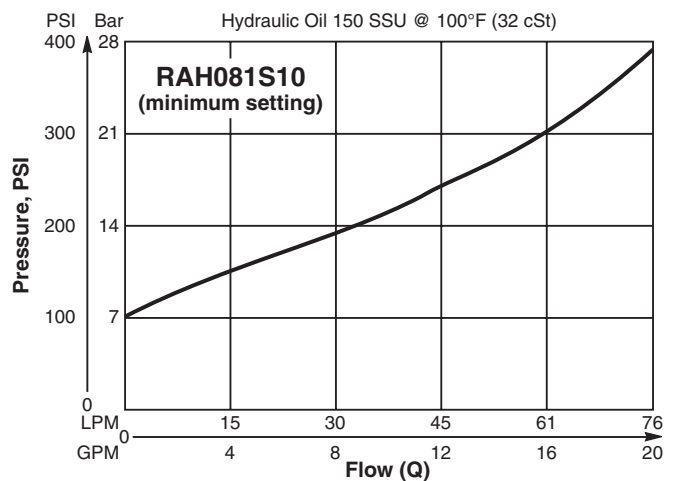
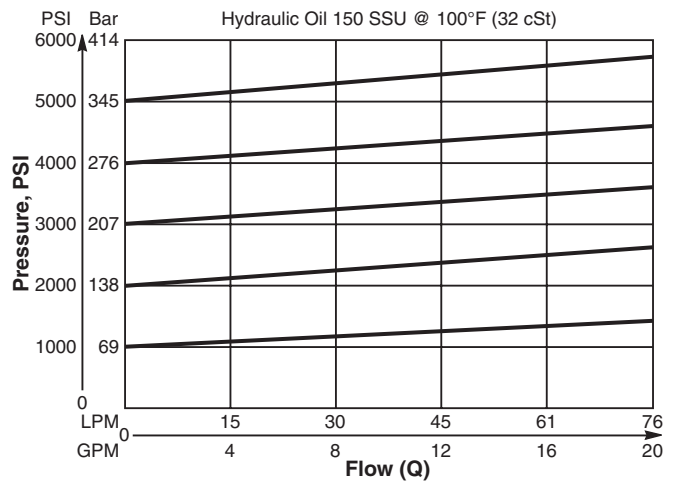

**Dimensions** Millimeters (Inches)

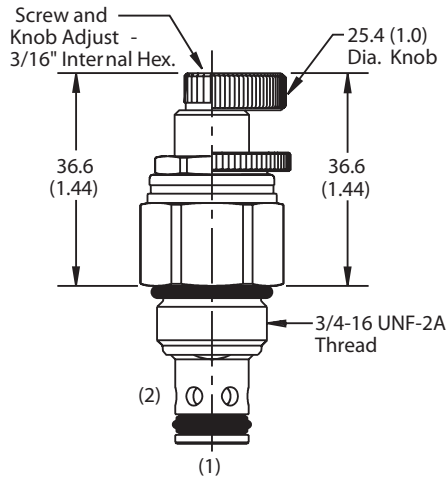

Screw/Knob Version

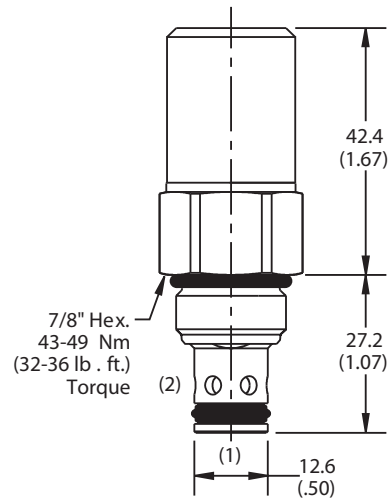

Tamper Resistant Version

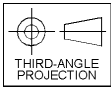

**Ordering Information**

<b>RAH081</b>			
08 Size Pilot Operated Relief Valve	Adjustment Style	Pressure Range	Seals

**Highlighted** represents preferred options that offer the shortest lead times. Other options may be available, but at extended lead times.

Code	Adjustment Style / Kit No.
K	Knob Adjust (717784-10)
<b>S</b>	<b>Screw Adjust</b>
T	Tamper Resistant Cap (717943)

Code	Seals / Kit No.
Omit	<b>"D"-Ring / (SK08-2)</b>
N	Nitrile / (SK08-2)
V	Fluorocarbon / (SK08-2V)

Code	Pressure Range
10	6.9 - 69 Bar (100 - 1000 PSI) Standard Setting: 34.5 Bar (500 PSI) @ crack pressure, approximately .95 LPM (.25 GPM)
30	13.8 - 207 Bar (200 - 3000 PSI) Standard Setting: 103.5 Bar (1500 PSI) @ crack pressure, approximately .95 LPM (.25 GPM)
50	13.8 - 345 Bar (200 - 5000 PSI) Standard Setting: 172.4 Bar (2500 PSI) @ crack pressure, approximately .95 LPM (.25 GPM)

Order Bodies Separately  
 See section BC

<b>B08</b>	—	<b>2</b>	—	
08 size		2-Way Cavity		Port Size

Code	Porting / Body Material
6T	SAE-6 / Steel (5000 PSI)
A6T	SAE-6 / Aluminium (3000 PSI)

CV
Check Valves
SH
Shuttle Valves
LM
Load/Motor Controls
FC
Flow Controls
<b>PC</b>
Pressure Controls
LE
Logic Elements
DC
Directional Controls
MV
Manual Valves
SV
Solenoid Valves
PV
Proportional Valves
CE
Coils & Electronics
CB
Cartrpак Bodies
BC
Bodies & Cavities
TD
Technical Data