

OPERATION

This is an in-line restrictive type flow control valve.

Schematic

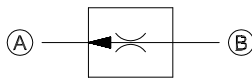

Theoretical performance

Pressure drop from A ⇒ B according to orifice diameter
 26 cSt [121 SUS] hyd.oil at 50°C [122 °F]

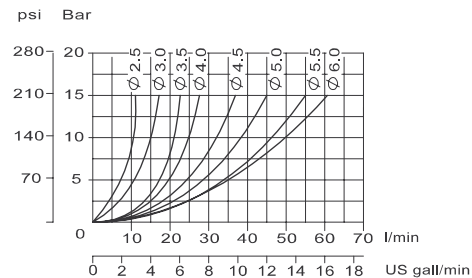

SPECIFICATIONS

Specifications

Pressure rating	207 bar [3000 psi]
Max regulated flow	47 l/min [12 US gal/min]
Cavity	Consult factory

Variation in controlled flow from B ⇒ A according to pressure
 26 cSt [121 SUS] hyd.oil at 50°C [122 °F]

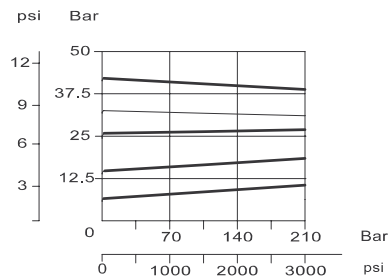

DIMENSIONS

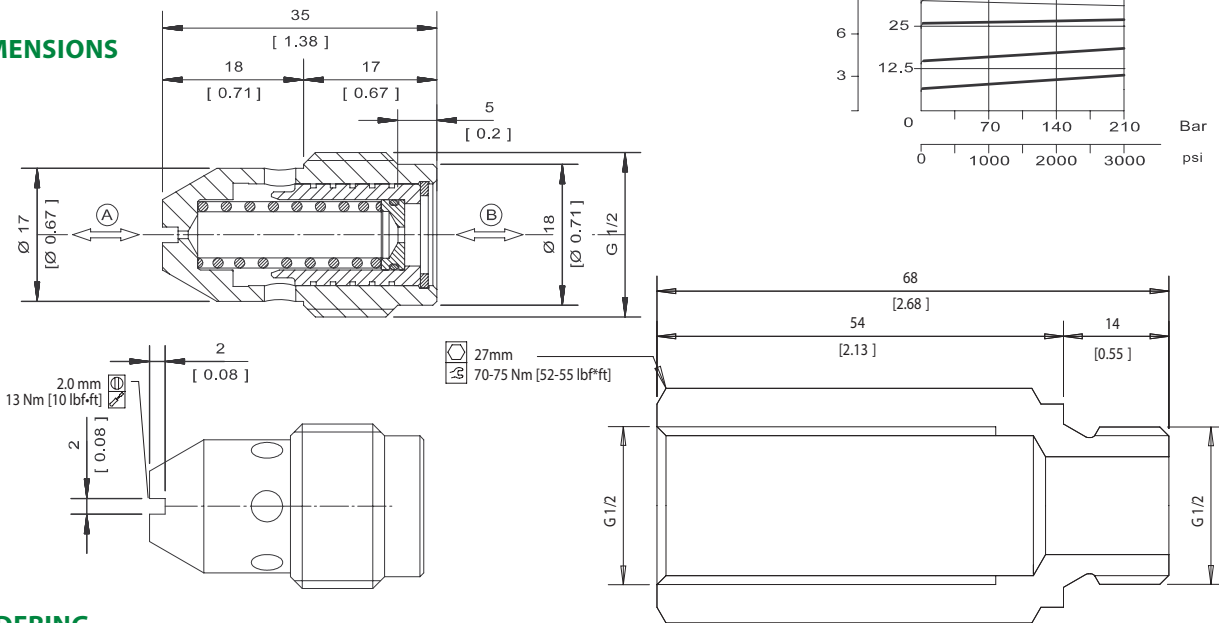

ORDERING INFORMATION

SC13/4.5 - G - 00

Orifice flow	Orifice diameter mm	Flow at 100 bar [1450 psi] l/min [US gal/min]	00 = Cartridge only
	2.50	9 [2.38]	L = 1/2 BSP
	3.00	12 [3.17]	
	3.50	17 [4.49]	
	4.00	21 [5.55]	
	4.50	27 [7.13]	
	5.00	32 [8.45]	
	5.50	40 [10.57]	
	6.00	47 [12.42]	