

PUMP DATA	
DISPLACEMENT	27,0 ccm
MAX. CONT. PRESSURE	190 bar
SPEED RATE	500 TO 1600 min ⁻¹
MAX. INPUT SHAFT TORQUE	198 NM
ROTATION	ANTI CLOCKWISE

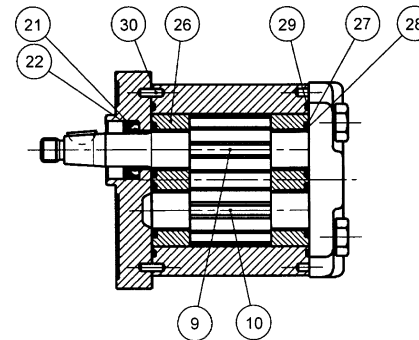

NOTE

FOR ASSEMBLY INSTRUCTIONS SEE DWG. NO. "511-B1"
"PGP511 PUMP ASSEMBLY INSTRUCTIONS".

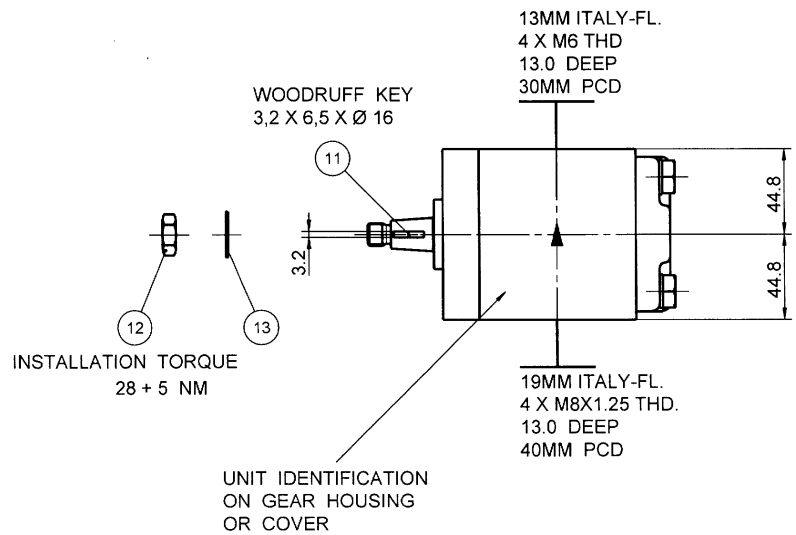
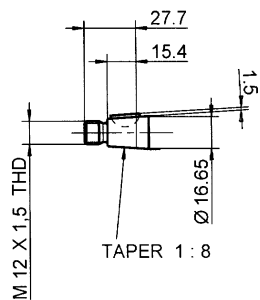
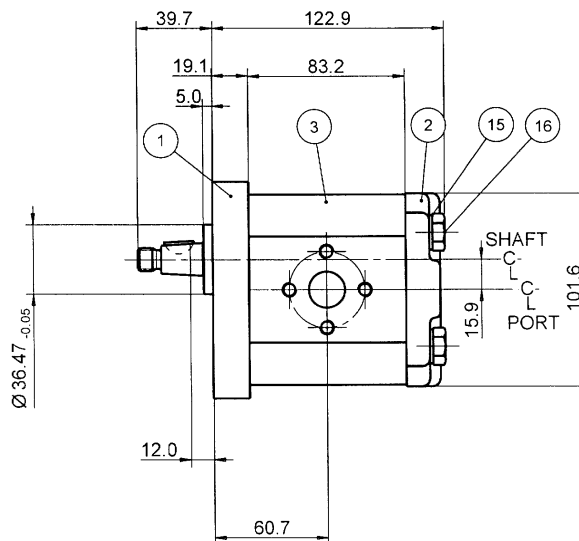
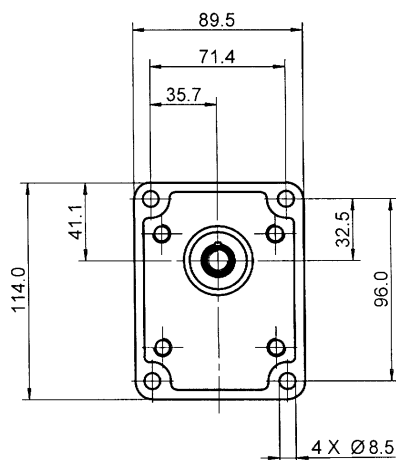

ITEM	PART NO	REQD	ITEM	PART NO	REQD
28	8611-015-000	2	SEAL. BK-UP	36	
27	8611-016-00R	2	SEAL. CHAN.	35	
26	8898-207-00U	2	THRBLK/BSHG	34	
25				33	
24				32	
23				31	
22	9211-323-00B	1	RING, SNAP	30	391 2080 078 2
21	8301-019-00K	1	SEAL. LIP	29	9313-145-00B 2
					SEAL. SECT.

20					
19					
18					
17					
16	391 1401 861	4	SCREW	(113 MM)	
15	391 3782 231	4	WASHER		
14					
13	391 3782 307	1	WASHER		
12	391 1451 168	1	NUT		
11	391 1781 112	1	KEY		
10	334 2727 000	1	DRIVEN GEAR		
9	334 1827 601	1	DRIVE GEAR		
8					
7					
6					
5					
4					
3	334 8127 907	1	HOUSING. GEAR		
2	332 3000 100	1	HOUSING. PEC		
1	334 5041 202	1	HOUSING. SEC		
ITEM	PART NO	REQ'D	DESCRIPTION		

THIRD ANGLE PROJECTION

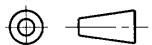

EXP NO.	
FIRST USED	03 - 09 - 946
	334 9112 560

SYM.	REVISIONS

THIS DOCUMENT CONTAINS INFORMATION THAT IS CONFIDENTIAL AND PROPRIETARY TO PARKER HANNIFIN CORPORATION. ("PARKER"). THIS DOCUMENT IS FURNISHED ON THE UNDERSTANDING THAT THE DOCUMENT AND INFORMATION WILL BE NOT COPIED OR DISCLOSED TO OTHERS OR USED FOR ANY PURPOSE OTHER THAN CONDUCTING BUSINESS WITH PARKER, AND WILL BE RETURNED AND ALL FURTHER USE DISCONTINUED UPON REQUEST BY PARKER. ALL RIGHTS RESERVED.

PGP511A0270AS2D3NL2L1B1B1

MATERIAL	ADM CTR P
REV DTE	24SEP03
H.E.-STD:	WT 4.3 Kg
DIMENSIONS ARE <u>MM</u>	

Parker		Hydraulic Controls Division	
		Werk Sachsenhydraulik	
		Chemnitz	
DR. BY	DATE	CH. BY	DATE
PG	11SEP03	UH	11SEP03
		SCALE 1/2	
334 9112 560			
© 2003 Parker-Hannifin Corporation			