

PUMP DATA	
DISPLACEMENT	14,0 ccm
MAX. CONT. PRESSURE	250 bar
SPEED RATE	500 TO 3100 min ⁻¹
MAX. INPUT SHAFT TORQUE	198 NM
ROTATION	ANTI CLOCKWISE

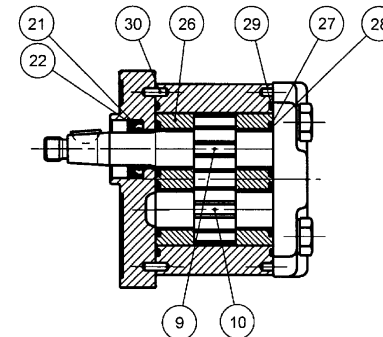
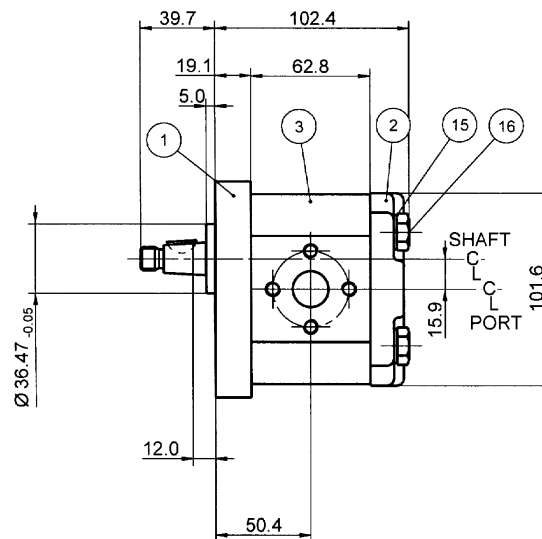
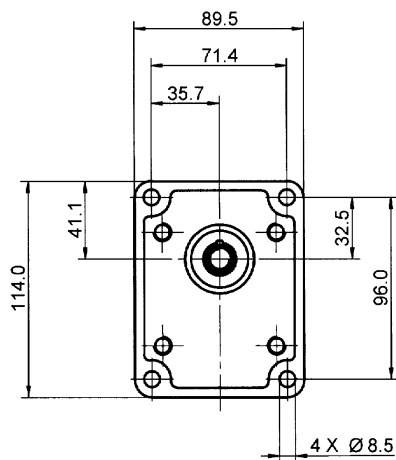
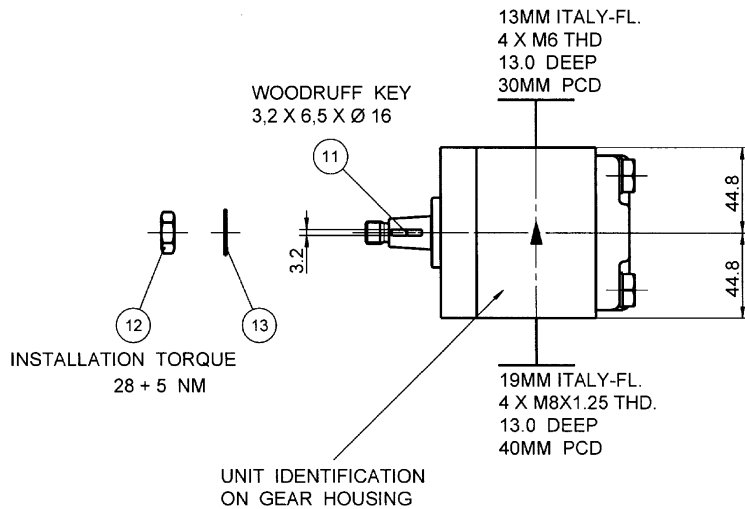
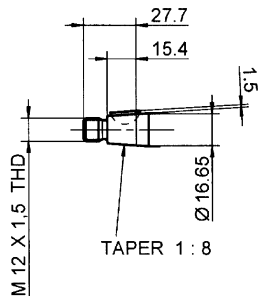

NOTE

FOR ASSEMBLY INSTRUCTIONS SEE DWG. NO. "511-B1" "PGP511 PUMP ASSEMBLY INSTRUCTIONS".

ITEM	PART NO	REQD	ITEM	PART NO	REQD
28	8611-015-000	2	SEAL. BK-UP	36	
27	8611-016-00R	2	SEAL. CHAN.	35	
26	8898-207-00U	2	THRBLK/BSHG	34	
25				33	
24				32	
23				31	
22	9211-323-00B	1	RING, SNAP	30	391 2080 078 2
21	8301-019-00K	1	SEAL. LIP	29	9313-145-00B 2

20					
19					
18					
17					
16	391 1401 543	4	SCREW (90 MM)		
15	391 3782 231	4	WASHER		
14					
13	391 3782 307	1	WASHER		
12	391 1451 168	1	NUT		
11	391 1781 112	1	KEY		
10	334 2714 000	1	DRIVEN GEAR		
9	334 1814 601	1	DRIVE GEAR		
8					
7					
6					
5					
4					
3	334 8114 907	1	HOUSING. GEAR		
2	332 3000 100	1	HOUSING. PEC		
1	334 5041 202	1	HOUSING. SEC		
ITEM	PART NO	REQD	DESCRIPTION		

THIRD ANGLE PROJECTION

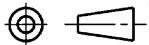

EXP. NO.

FIRST USED

02 - 10 - 99901

334 9112 400

DWG. REDRAWN

SYM. REVISIONS

THIS DOCUMENT CONTAINS INFORMATION THAT IS CONFIDENTIAL AND PROPRIETARY TO PARKER HANNIFIN CORPORATION ("PARKER"). THIS DOCUMENT IS FURNISHED ON THE UNDERSTANDING THAT THE DOCUMENT AND INFORMATION WILL BE NOT COPIED OR DISCLOSED TO OTHERS OR USED FOR ANY PURPOSE OTHER THAN CONDUCTING BUSINESS WITH PARKER, AND WILL BE RETURNED AND ALL FURTHER USE DISCONTINUED UPON REQUEST BY PARKER. ALL RIGHTS RESERVED.

PGP511A0140AS2D3NL2L1B1B1

MATERIAL

H.E.-STD

ADM CTR

REV DTE 26JUN03

WT 3.8 Kg

P

DIMENSIONS ARE —MM—

Hydraulic Controls Division
 Sachsenhydraulik GmbH
 Chemnitz

DR BY DATE PW 24OCT02 CH BY DATE JS 24OCT02 SCALE 1/2

334 9112 400

© 2003 Parker-Hannifin Corporation