

Axial Piston Variable Pump AA11VO

RA 92500-A/10.09 1/68
Replaces: 06.09

Data sheet

Series 1
Size NG40 to 260
Nominal pressure 5100 psi (350 bar)
Maximum pressure 5800 psi (400 bar)
Open circuit



Contents

Ordering code for standard program	2
Technical data	5
LR – Power control	10
DR – Pressure control	21
HD – Hydraulic control, pilot-pressure related	25
EP – Electric control with proportional solenoid	27
Dimensions size 40	30
Dimensions size 60	34
Dimensions size 75	38
Dimensions size 95	42
Dimensions size 130/145	46
Dimensions size 190	50
Dimensions size 260	54
Through drive dimensions	58
Overview of attachments for AA11V(L)O	61
Combination pumps AA11VO + AA11VO	62
Swivel angle indicator	63
Connector for solenoids	64
Installation notes	65
General notes	68

Features

- Variable axial piston pump of swashplate design for hydrostatic drives in open circuit hydraulic system.
- Designed primarily for use in mobile applications.
- The pump operates under self-priming conditions, with tank pressurization, or with an optional built-in charge pump (impeller).
- A comprehensive range of control options is available matching any application requirement.
- Power control option is externally adjustable, even when the pump is running.
- The through drive is suitable for adding gear pumps and axial piston pumps up to the same size, i.e. 100% through drive.
- The output flow is proportional to the drive speed and infinitely variable between $q_{V \max}$ and $q_{V \min} = 0$.

Ordering code for standard program

AA11V		O			/	1			-	N							
01	02	03	04	05		06	07	08		09	10	11	12	13	14	15	16

Axial piston unit

01	Swashplate design, variable, nominal pressure 5100 psi (350 bar), maximum pressure 5800 psi (400 bar)	AA11V
----	---	--------------

Charge pump (impeller)

		40	60	75	95	130	145	190	260	
02	without charge pump (no code)	●	●	●	●	●	●	●	●	
	with charge pump	-	-	-	-	●	●	●	●	L

Operation

03	Pump, open circuit	O
----	--------------------	----------

Size

		40	60	75	95	130	145	190	260
04	≈ Displacement $V_{g \max}$	42	58.5	74	93.5	130	145	193	260
	cm ³ /rev.	2.56	3.57	4.52	5.71	7.93	8.84	11.78	15.87
	in ³ /rev.								

Control unit

						40	60	75	95	130	145	190	260	
05	Power control		LR			●	●	●	●	●	●	●	●	LR
	with override	cross sensing	negative	LR	C	●	●	●	●	●	●	●	●	LR.C
		high-pressure related	negative	LR3		●	●	●	●	●	●	●	●	LR3
		pilot-pressure related	negative	LG1		●	●	●	●	●	●	●	●	LG1
			positive	LG2		●	●	●	●	●	●	●	●	LG2
		electric	U = 12 V	negative	LE1		○	○	○	●	●	●	●	LE1
			U = 24 V	negative	LE2		○	●	●	●	●	●	●	LE2
		with pressure cut-off			D		●	●	●	●	●	●	●	L.D.
			hydraulic, 2-stage		E		●	●	●	●	●	●	●	L.E.
			hydraulic, remote controlled			G	●	●	●	●	●	●	●	L..G.
		with load sensing				S	●	●	●	●	●	●	●	L...S
			electric, prop. override, 24 V			S2	○	○	○	●	●	●	●	L...S2
			hydraulic, prop. override			S5	○	○	○	●	●	●	●	L...S5
		with stroke limiter	negative	$\Delta p=365$ psi (25 bar)		H1	●	●	●	●	●	●	●	L...H1
			characteristic	$\Delta p=145$ psi (10 bar)		H5	●	●	●	●	●	●	●	L...H5
				$\Delta p=365$ psi (25 bar)		H2	●	●	●	●	●	●	●	L...H2
			positive	$\Delta p=145$ psi (10 bar)		H6	●	●	●	●	●	●	●	L...H6
			characteristic	U = 12 V		U1	●	●	●	●	●	●	●	L...U1
				U = 24 V		U2	●	●	●	●	●	●	●	L...U2
		Pressure control			DR		●	●	●	●	●	●	●	DR
		with load sensing		DRS		●	●	●	●	●	●	●	DRS	
		remote controlled		DRG		●	●	●	●	●	●	●	DRG	
		for parallel operation		DRL		●	●	●	●	●	●	●	DRL	
	Hydraulic control		$\Delta p=145$ psi (10 bar)	HD1		●	●	●	●	●	●	●	HD1	
	pilot-pressure related	(positive characteristic)	$\Delta p=365$ psi (25 bar)	HD2		●	●	●	●	●	●	●	HD2	
		with pressure cut-off		D		●	●	●	●	●	●	●	HD.D	
		with pressure cut-off, remote controlled		G		○	●	○	○	○	○	●	HD.G	
	Electric control		U = 12 V	EP1		●	●	●	●	●	●	●	EP1	
	with proportional solenoid	(positive characteristic)	U = 24 V	EP2		●	●	●	●	●	●	●	EP2	
		with pressure cut-off		D		●	●	●	●	●	●	●	EP.D	
		with pressure cut-off, remote control		G		●	●	●	●	●	●	●	EP.G	

In case of controls with several additional functions, observe the order of the columns, only one option per column is possible (e.g. LRDCH2). The following combinations are not available for the power control: LRDS2, LRDS5, L...GS, L...GS2, L...GS5, L...EC and the combination L...DG in conjunction with the stroke limiters H1, H2, H5, H6, U1 and U2.

● = available ○ = on request - = not available

Ordering code for standard program

AA11V		O			/	1			-	N							
01	02	03	04	05		06	07	08		09	10	11	12	13	14	15	16

Series

06																	1
----	--	--	--	--	--	--	--	--	--	--	--	--	--	--	--	--	----------

Index

07																		0
																		1

Direction of rotation

08	Viewed from drive shaft																	R
																		L

Seals

09	NBR (nitrile-caoutchouc), shaft seal ring in FKM (fluor-caoutchouc)																	N
----	---	--	--	--	--	--	--	--	--	--	--	--	--	--	--	--	--	----------

Drive shaft (see page 8 for permissible input and through drive torques)

		40	60	75	95	130	145	190	260		
10	Parallel keyed shaft DIN 6885	●	●	●	●	●	●	●	●	P	
	Splined shaft ANSI B92.1a-1976	for single pump	●	●	●	●	●	●	●	●	S
		for combination pump	●	●	●	- ¹⁾	- ¹⁾	- ¹⁾	●	●	T

Mounting flange

		40	60	75	95	130	145	190	260	
11	SAE J744 – 2-hole	●	●	-	-	-	-	-	-	C
	SAE J744 – 4-hole	-	-	●	●	●	●	●	●	D
	SAE J617 ²⁾ (SAE 3)	-	-	-	●	●	●	●	-	G

Service line ports

		40	60	75	95	130	145	190	260	
12	Pressure and suction port SAE, at side, opposite side (with UNC fastening threads)	●	●	●	●	●	●	●	●	62

Through drive (see page 58 for attachments)

		40	60	75	95	130	145	190	260		
13	Flange SAE J744 ³⁾ Coupler for splined shaft										
	-	●	●	●	●	●	●	●	●	N00	
	82-2 (A)	5/8in 9T 16/32DP (A)	●	●	●	●	●	●	●	●	K01
		3/4in 11T 16/32DP (A-B)	○	●	○	●	●	●	○	○	K52
	101-2 (B)	7/8in 13T 16/32DP (B)	●	●	●	●	●	●	●	●	K02
		1 in 15T 16/32DP (B-B)	●	●	●	●	●	●	●	●	K04
	127-2 (C) ⁴⁾	1 1/4in 14T 12/24DP (C)	-	●	●	●	●	●	●	●	K07
		1 1/2in 17T 12/24DP (C-C)	-	-	-	●	●	●	●	●	K24
	152-4 (D)	1 1/4in 14T 12/24DP (C)	-	-	●	●	●	●	●	●	K86
		1 3/4in 13T 8/16DP (D)	-	-	-	-	●	●	●	●	K17
	165-4 (E)	1 3/4in 13T 8/16DP (D)	-	-	-	-	-	-	●	●	K72

1) S-shaft suitable for combination pump!

2) To fit the flywheel case of the combustion engine

3) 2 ≙ 2-hole; 4 ≙ 4-hole

4) Size 190 and 260 with 2 + 4-hole flange

● = available

○ = on request

- = not available

Ordering code for standard program

AA11V		O			/	1			-	N						
01	02	03	04	05		06	07	08		09	10	11	12	13	14	15

Swivel angle indicator (page 63)

		40	60	75	95	130	145	190	260	
14	without swivel angle indicator (no symbol)	●	●	●	●	●	●	●	●	
	with optical swivel angle indicator	●	-	●	●	●	●	●	●	V
	with electric swivel angle sensor	●	-	●	●	●	●	●	●	R

Connector for solenoids (page 64)

		40	60	75	95	130	145	190	260	
15	DEUTSCH connector molded, 2-pin – without suppressor diode	●	●	●	●	●	●	●	●	P

Standard / special version

16	Standard version	without symbol	
		combined with attachment part or attachment pump	-K
	Special version		-S
		combined with attachment part or attachment pump	-SK

Technical data

Hydraulic fluid

Before starting project planning, please refer to our data sheets RE 90220 (mineral oil), RE 90221 (environmentally acceptable hydraulic fluids) and RE 90223 (HF hydraulic fluids) for detailed information regarding the choice of hydraulic fluid and operating conditions.

The variable pump AA11VO is not suitable for operating with HFA, HFB and HFC. If HFD or environmentally acceptable hydraulic fluids are being used, the limitations regarding technical data and seals mentioned in RE 90221 and RE 90223 must be observed.

When ordering, indicate the hydraulic fluid that is to be used.

Operating viscosity range

For optimum efficiency and service life, select an operating viscosity (at operating temperature) within the optimum range of

$$v_{\text{opt}} = \text{opt. operating viscosity } 80 \text{ to } 170 \text{ SUS } (16 \text{ to } 36 \text{ mm}^2/\text{s})$$

depending on the tank temperature (open circuit).

Limits of viscosity range

The limiting values for viscosity are as follows:

- $v_{\text{min}} = 42 \text{ SUS } (5 \text{ mm}^2/\text{s})$
 Short-term ($t < 3 \text{ min}$)
 At max. perm. temperature of $t_{\text{max}} = 240 \text{ }^\circ\text{F } (+115 \text{ }^\circ\text{C})$.
- $v_{\text{max}} = 7400 \text{ SUS } (1600 \text{ mm}^2/\text{s})$
 Short-term ($t < 3 \text{ min}$)
 At cold start ($p \leq 435 \text{ psi } (30 \text{ bar})$, $n \leq 1000 \text{ rpm}$,
 $t_{\text{min}} = -40 \text{ }^\circ\text{F } (-40 \text{ }^\circ\text{C})$).
 Only for starting up without load. Optimum operating viscosity must be reached within approx. 15 minutes.

Note that the maximum hydraulic fluid temperature of $240 \text{ }^\circ\text{F } (115 \text{ }^\circ\text{C})$ must not be exceeded locally either (e.g. in the bearing area). The temperature in the bearing area is – depending on pressure and speed – up to $9^\circ\text{F } (5 \text{ K})$ higher than the average case drain temperature.

Special measures are necessary in the temperature range from $-40 \text{ }^\circ\text{F } (-40 \text{ }^\circ\text{C})$ and $-13 \text{ }^\circ\text{F } (-25 \text{ }^\circ\text{C})$ (cold start phase), please contact us.

For detailed information about use at low temperatures, see RE 90300-03-B.

Selection diagram

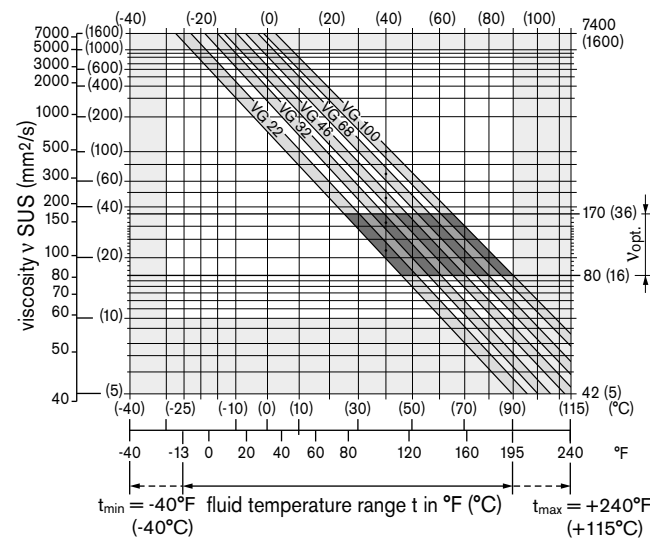

Details regarding the choice of hydraulic fluid

The correct choice of hydraulic fluid requires knowledge of the operating temperature in relation to the ambient temperature: in an open circuit the tank temperature.

The hydraulic fluid should be chosen so that the operating viscosity in the operating temperature range is within the optimum range (v_{opt}) – see the shaded area of the selection diagram. We recommended that the higher viscosity class be selected in each case.

Example: At an ambient temperature of $X \text{ }^\circ\text{C}$ an operating temperature of $140 \text{ }^\circ\text{F } (60 \text{ }^\circ\text{C})$ is set. In the optimum operating viscosity range (v_{opt} ; shaded area) this corresponds to the viscosity classes VG 46 and VG 68; to be selected: VG 68.

Note

The case drain temperature, which is affected by pressure and speed, is always higher than the tank temperature. At no point in the system may the temperature be higher than $240 \text{ }^\circ\text{F } (115^\circ\text{C})$.

If the above conditions cannot be maintained due to extreme operating parameters, please contact us.

Filtration

The finer the filtration, the higher the cleanliness level of the hydraulic fluid and the longer the service life of the axial piston unit.

To ensure functional reliability of the axial piston unit, the hydraulic fluid must have a cleanliness level of at least 20/18/15 according to ISO 4406.

At very high hydraulic fluid temperatures ($195 \text{ }^\circ\text{F } (90 \text{ }^\circ\text{C})$ to maximum $240 \text{ }^\circ\text{F } (115 \text{ }^\circ\text{C})$, at least cleanliness level 19/17/14 according to ISO 4406 is required.

If the above classes cannot be observed, please contact us.

Technical data

Operating pressure range

Inlet

Absolute pressure at port S (suction port)
Version **without** charge pump

$p_{abs \text{ min}}$ _____ 12 psi (0.8 bar)
 $p_{abs \text{ max}}$ _____ 435 psi (30 bar)

If the pressure is > 75 psi (5 bar), please ask.

Version **with** charge pump

$p_{abs \text{ min}}$ _____ 9 psi (0.6 bar)
 $p_{abs \text{ max}}$ _____ 30 psi (2 bar)

Maximum permissible speed (speed limit)

Permissible speed by increasing the inlet pressure p_{abs} at the suction port S or at $V_g \leq V_{g \text{ max}}$

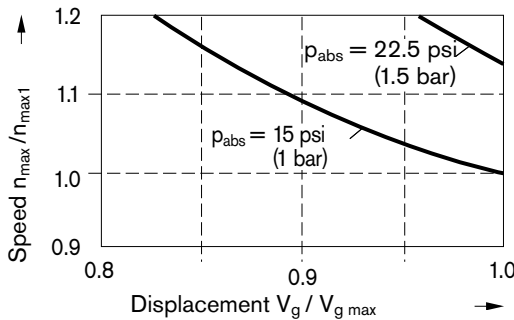

Outlet

Pressure at port A or B

Nominal pressure p_N _____ 5100 psi (350 bar)
Maximum pressure p_{max} _____ 5800 psi (400 bar)

Nominal pressure: Maximum design pressure at which fatigue strength is ensured.

Maximum pressure: Maximum operating pressure which is permissible for short-term ($t < 1s$).

Minimum operating pressure

A minimum operating pressure $p_{B \text{ min}}$ is required in the pump service line depending on the speed, the swivel angle and the displacement (see diagram).

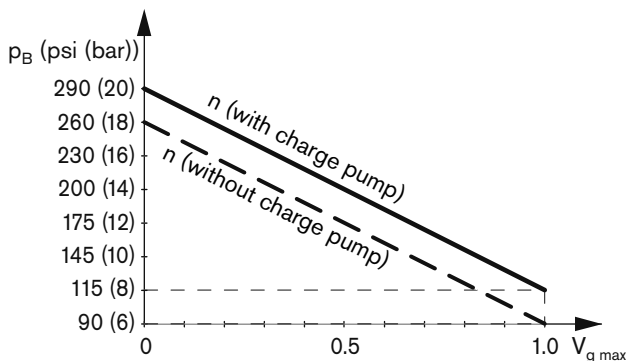

Case drain pressure

The case drain pressure at the ports T_1 and T_2 may be a maximum of 17.5 psi (1.2 bar) higher than the inlet pressure at the port S but not higher than

$p_{L \text{ abs. max}}$ _____ 30 psi (2 bar).

An unrestricted, full size case drain line directly to tank is required.

Temperature range of the shaft seal ring

The FKM shaft seal ring is permissible for case drain temperatures of -13 °F to 240 °F (-25 °C to +115 °C).

Note

For applications below -13 °F (-25 °C), an NBR shaft seal ring is necessary (permissible temperature range: -40 °F to 194 °F (-40 °C to +90 °C)).

State NBR shaft seal ring in clear text in the order.

Flushing the case

If a variable pump with control unit **EP, HD, DR** or stroke limiter (**H., U.,**) is operated over a long period ($t > 10 \text{ min}$) with flow zero or operating pressure < 220 psi (15 bar), flushing of the case via ports "T₁", "T₂" or "R" is necessary.

Size	40	60	75	95	130	145	190	260
qV_{flush} gpm	0.5	0.8	0.8	1.0	1.0	1.0	1.3	1.6
(l/min)	2	3	3	4	4	4	5	6

Flushing the case is unnecessary in versions with charge pump (AA11VLO), since a part of the charge flow is directed to the case.

Charge pump (impeller)

The charge pump is a circulating pump with which the AA11VLO (size 130 to 260) is filled and therefore can be operated at higher speeds. This also simplifies cold starting at low temperatures and high viscosity of the hydraulic fluid. Tank charging is therefore unnecessary in most cases. A tank pressure of a maximum 30 psi (2 bar) is permissible with charge pump.

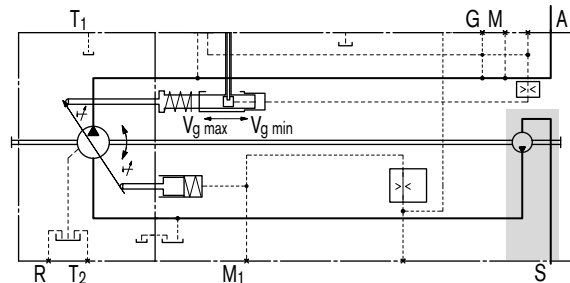

Technical data

Table of values (theoretical values, without efficiency and tolerances; values rounded)

Size	AA11VO		40	60	75	95	130	145	190	260
Displacement	$V_{g \max}$	l ³ /rev.	2.56	3.57	4.52	5.71	7.93	8.84	11.78	15.87
		cm ³	42	58.5	74	93.5	130	145	193	260
	$V_{g \min}$	cm ³	0	0	0	0	0	0	0	0
Speed	n_{\max}	rpm	3000	2700	2550	2350	2100	2200	2100	1800
		maximum at $V_{g \max}$ ¹⁾								
	$n_{\max 1}$	rpm	3500	3250	3000	2780	2500	2500	2100	2300
Flow	$q_{v \max}$	gpm	33.3	41.7	49.9	58.1	72.1	84.3	107	123.6
		l/min	126	158	189	220	273	319	405	468
Power at $q_{v \max}$ and $\Delta p = 350$ bar	P_{\max}	hp	99.2	123.4	147.5	171.7	213.2	249.4	316.5	366.1
		kW	74	92	110	128	159	186	236	273
Torque at $V_{g \max}$ and $\Delta p = 350$ bar	T_{\max}	lb-ft	172.6	240.4	303.9	384.3	534	596	792.9	1068
		Nm	234	326	412	521	724	808	1075	1448
Rotary stiffness	P shaft	lb-ft/rad	64512	79574	105548	14883	230417	230417	282702	482244
		Nm/rad	87467	107888	143104	196435	312403	312403	383292	653835
	S shaft	lb-ft/rad	43035	63658	75173	128117	174700	174700	191599	259628
		Nm/rad	58347	86308	101921	173704	236861	236861	259773	352009
	T shaft	lb-ft/rad	54931	75556	92640	–	–	–	222691	418282
		Nm/rad	74476	102440	125603	–	–	–	301928	567115
Moment of inertia for rotary group	J_{TW}	lbs-ft ²	0.1139	0.1946	0.2729	0.4105	0.7546	0.8092	1.3052	2.0835
		kgm ²	0.0048	0.0082	0.0115	0.0173	0.0318	0.0341	0.055	0.0878
Angular acceleration, maxi- mum ³⁾	α	rad/s ²	22000	17500	15000	13000	10500	9000	6800	4800
Filling capacity	V	gal	0.29	0.36	0.49	0.55	0.77	0.77	1.0	1.22
		L	1.1	1.35	1.85	2.1	2.9	2.9	3.8	4.6
Mass (approx.)	m	lbs	71	88	99	117	145	168	209	276
		kg	32	40	45	53	66	76	95	125

1) The values apply at absolute pressure (p_{abs}) 15 psi (1 bar) at the suction port S and mineral hydraulic fluid.

2) The values apply at $V_g \leq V_{g \max}$ or in case of an increase in the inlet pressure p_{abs} at the suction port S (see diagram page 6)

3) The area of validity is situated between 0 and the maximum permissible speed.

It applies for external stimuli (e.g. engine 2 to 8 times rotary frequency, cardan shaft twice the rotary frequency).

The limit value applies for a single pump only.

The loading on the connection parts has to be considered.

Caution

Exceeding the permissible limit values could cause a loss of function, reduced service life or the destruction of the axial piston unit. The permissible values can be determined by calculation.

Technical data

Table of values (theoretical values, without efficiency and tolerances; values rounded)

Size	AA11VLO (with charge pump)		130	145	190	260
Displacement	$V_{g \max}$	l ³ /rev.	7.93	8.84	11.78	15.87
		cm ³	130	145	193	260
	$V_{g \min}$	cm ³	0	0	0	0
Speed	n_{\max}	rpm	2500	2500	2500	2300
		maximum at $V_g \leq V_{g \max}^{2)}$	rpm	2500	2500	2500
Flow at n_{\max} and $V_{g \max}$	$q_{v \max}$	gpm	85.9	95.9	127.6	158
		l/min	325	363	483	598
Power at $q_{v \max}$ and $\Delta p = 350$ bar	P_{\max}	hp	254.8	283	376.8	468
		kW	190	211	281	349
Torque at $V_{g \max}$ and $\Delta p = 350$ bar	T_{\max}	lb-ft	534	596	792.9	1068
		Nm	724	808	1075	1448
Rotary stiffness	P shaft	lb-ft/rad	230417	230417	282702	482244
		Nm/rad	312403	312403	383292	653835
	S shaft	lb-ft/rad	174700	174700	191599	259628
		Nm/rad	236861	236861	259773	352009
	T shaft	lb-ft/rad	–	–	222691	418282
		Nm/rad	–	–	301928	567115
Moment of inertia for rotary group	J_{TR}	lbs-ft ²	0.7997	0.8543	1.3692	2.1238
		kgm ²	0.0337	0.036	0.0577	0.0895
Angular acceleration, maximum ³⁾	α	rad/s ²	10500	9000	6800	4800
Filling capacity	V	gal	0.77	0.77	1.0	1.22
		L	2.9	2.9	3.8	4.6
Mass (approx.)	m	lbs	159	161	229	304
		kg	72	73	104	138

1) The values apply at absolute pressure (p_{abs}) of at least 12 psi (0.8 bar) at the suction port S and mineral hydraulic fluid.

2) The values apply at $V_g \leq V_{g \max}$ or in case of an increase in the inlet pressure p_{abs} at the suction port S (see diagram page 6)

3) The area of validity is situated between 0 and the maximum permissible speed.

It applies for external stimuli (e.g. engine 2 to 8 times rotary frequency, cardan shaft twice the rotary frequency).

The limit value applies for a single pump only.

The loading on the connection parts has to be considered.

Caution

Exceeding the permissible limit values could cause a loss of function, reduced service life or the destruction of the axial piston unit. The permissible values can be determined by calculation.

Determining the size

$$\begin{aligned}
 \text{Flow } q_v &= \frac{V_g \cdot n \cdot \eta_v}{231} \quad [\text{gpm}] && \left(\frac{V_g \cdot n \cdot \eta_v}{1000} \right) \quad [\text{l/min}] && V_g = \text{Displacement per revolution [cm}^3\text{]} \\
 \text{Torque } T &= \frac{V_g \cdot \Delta p}{24 \cdot \pi \cdot \eta_{mh}} \quad [\text{lb-ft}] && \left(\frac{V_g \cdot \Delta p}{20 \cdot \pi \cdot \eta_{mh}} \right) \quad [\text{Nm}] && \Delta_p = \text{Differential pressure [bar]} \\
 \text{Power } P &= \frac{2 \pi \cdot T \cdot n}{33000} = \frac{q_v \cdot \Delta p}{1714 \cdot \eta_t} \quad [\text{hp}] && \left(\frac{q_v \cdot \Delta p}{600 \cdot \eta_t} = \frac{2 \pi \cdot T \cdot n}{60000} \right) \quad [\text{kW}] && n = \text{Speed [rpm]} \\
 &&&&&& \eta_v = \text{Volumetric efficiency} \\
 &&&&&& \eta_{mh} = \text{Mechanical-hydraulic efficiency} \\
 &&&&&& \eta_t = \text{Total efficiency } (\eta_t = \eta_v \cdot \eta_{mh})
 \end{aligned}$$

Technical data

Permissible radial and axial loading on drive shaft

The values stated are maximum data and not permissible for continuous operation

Size	Size	40	60	75	95	130	145	190	260	
Radial force, maximum at distance a, b, c (from shaft collar)	$F_{q \max}$	lbf	809	1124	1416	1798	2472	2472	3805	4946
		N	3600	5000	6300	8000	11000	11000	16925	22000
	a	in	0.69	0.69	0.79	0.79	0.89	0.89	1.02	1.14
		mm	17.5	17.5	20	20	22.5	22.5	26	29
	$F_{q \max}$	lbf	650	910	1113	1424	1932	1932	2973	3779
		N	2891	4046	4950	6334	8594	8594	13225	16809
	b	in	1.18	1.18	1.38	1.38	1.57	1.57	1.81	1.97
		mm	30	30	35	35	40	40	46	50
	$F_{q \max}$	lbf	543	764	917	1178	1585	1585	2439	3057
		N	2416	3398	4077	5242	7051	7051	10850	13600
	c	in	1.67	1.67	1.97	1.97	2.26	2.26	2.60	2.80
		mm	42.5	42.5	50	50	57.5	57.5	66	71
Axial force, maximum	lbf	337	495	618	787	1079	1079	1349	933	
	N	1500	2200	2750	3500	4800	4800	6000	4150	

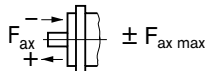
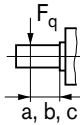

Permissible input and through drive torques

Size	Size	40	60	75	95	130	145	190	260	
Torque (at $V_{g \max}$ and $\Delta p = 5100 \text{ psi (350 bar}^1)$)	T_{\max}	lb-ft	173	240	304	384	534	596	793	1068
		Nm	234	326	412	521	724	808	1075	1448
Input torque, maximum ²⁾										
at shaft end P Shaft key DIN 6885	$T_{E \text{ perm.}}$	lb-ft	345	478	608	770	1068	1068	1642	2056
		Nm	468	648	824	1044	1448	1448	2226	2787
		DIA in	1.26	1.38	1.57	1.77	1.97	1.97	2.17	2.36
		DIA mm	ø32	ø35	ø40	ø45	ø50	ø50	ø55	ø60
at S shaft end ANSI B92.1a-1976 (SAE J744)	$T_{E \text{ perm.}}$	lb-ft	232	444	444	1210	1210	1210	1210	1210
		Nm	314	602	602	1640	1640	1640	1640	1640
		in	1 in	1 1/4 in	1 1/4 in	1 3/4 in	1 3/4 in	1 3/4 in	1 3/4 in	1 3/4 in
at T shaft end ANSI B92.1a-1976 (SAE J744)	$T_{E \text{ perm.}}$	lb-ft	444	715	715	–	–	–	1969	3002
		Nm	602	970	970	–	–	–	2670	4070
		in	1 1/4 in	1 3/8 in	1 3/8 in	–	–	–	2 in	2 1/4 in
Through drive torque, maximum ³⁾	$T_{D \text{ perm.}}$	lb-ft	232	384	487	606	819	819	1298	1523
		Nm	314	521	660	822	1110	1110	1760	2065

1) Efficiency not considered

2) For drive shafts with no radial force

3) Observe maximum input torque for shaft S!

Torque distribution

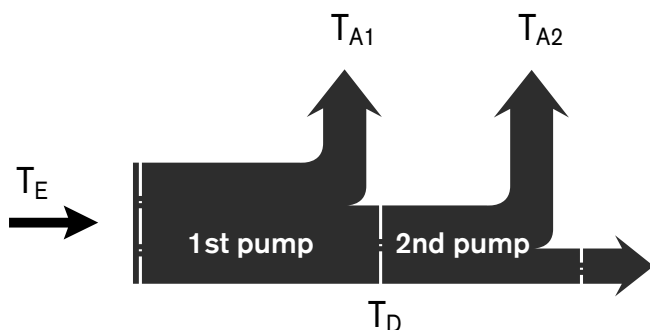

LR – Power control

The power control regulates the displacement of the pump depending on the operating pressure so that a given drive power is not exceeded at constant drive speed.

$$p_B \cdot V_g = \text{constant}$$

p_B = operating pressure
 V_g = displacement

The precise control with a hyperbolic control characteristic, provides an optimum utilization of available power.

The operating pressure acts on a rocker via a measuring piston. An externally adjustable spring force counteracts this, it determines the power setting.

If the operating pressure exceeds the set spring force, the control valve is actuated by the rocker, the pump swivels back (direction $V_{g \text{ min}}$). The lever length at the rocker is shortened and the operating pressure can increase at the same rate as the displacement decreases without the drive powers being exceeded ($p_B \cdot V_g = \text{constant}$).

The hydraulic output power (characteristic LR) is influenced by the efficiency of the pump.

State in clear text in the order:

- drive power P in kW
- drive speed n in rpm
- maximum flow $q_{V \text{ max}}$ in l/min

After clarifying the details a power diagram can be created by our computer.

Characteristic LR

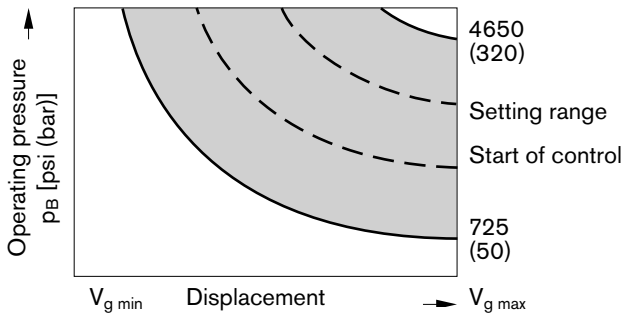

Circuit diagram LR

Size 40 to 145

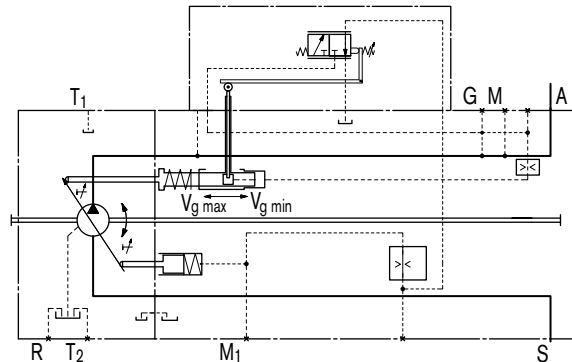

Size 190 to 260

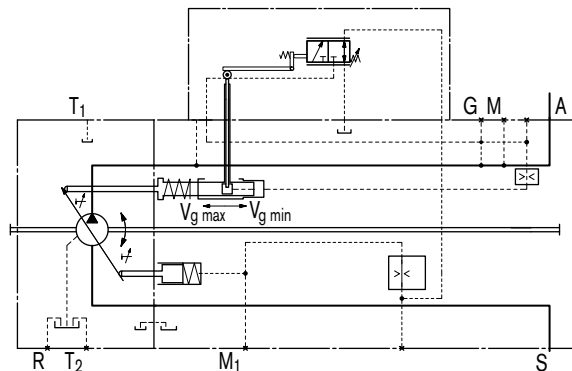

LR – Power control

LRC Override with cross sensing

Cross sensing control is a summation power control system, whereby the total power, of both the AA11VO and of a same size AA11VO power controlled pump mounted onto the through drive, are kept constant.

If a pump is operating at pressures below the start of the control curve setting, then the surplus power not required, in a critical case up to 100 %, becomes available to the other pump. Total power is thus divided between two systems as demand requires.

Any power being limited by means of pressure cut-off or other override functions is not taken into account.

Half side cross sensing function

When using the LRC control on the 1st pump (AA11VO) and a power-controlled pump without cross sensing attached to the through drive, the power required for the 2nd pump is deducted from the setting of the 1st pump. The 2nd pump has priority in the total power setting.

The size and start of control of the power control of the 2nd pump must be specified for rating the control of the 1st pump.

Circuit diagram LRC

Size 40 to 145

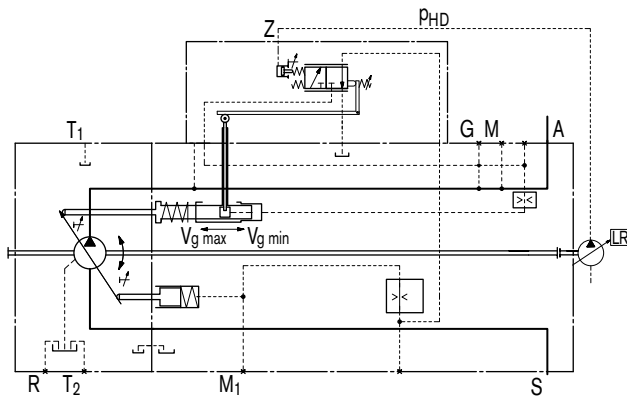

Size 190 to 260

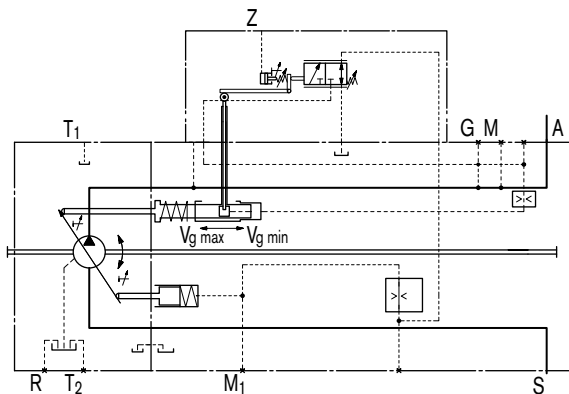

LR3 High-pressure related override

The high-pressure related power override is a total power control in which the power control setting is piloted by the load pressure of an attached fixed pump (port Z).

As a result the AA11VO can be set to 100 % of the total drive power. The power setting of the AA11VO is reduced proportional to the load-dependent rise in operating pressure of the fixed pump. The fixed pump has priority in the total power setting.

The measuring area of the power reduction pilot piston is designed as a function of the size of the fixed pump.

Circuit diagram LR3

Size 40 to 145

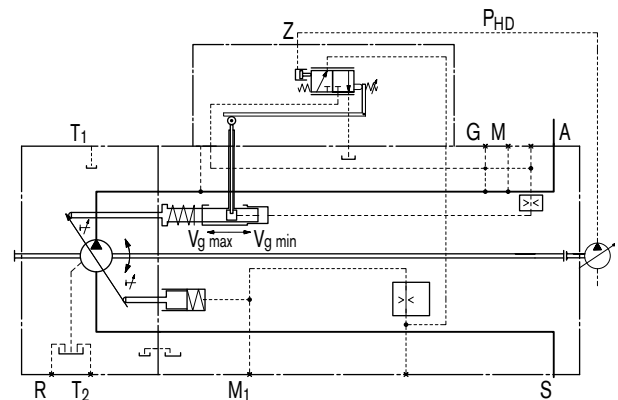

Size 190 to 260

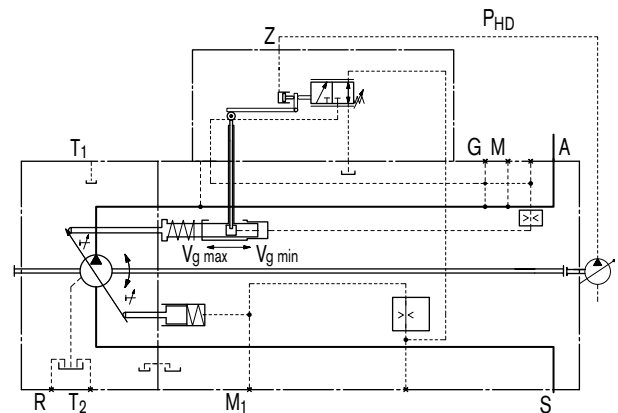

LR – Power control

LG1/2 Pilot-pressure related override

This power control works by overriding the control setting with an external pilot pressure signal. This pilot pressure acts on the adjustment spring of the power regulator via port Z.

The mechanically adjusted basic setting can be hydraulically adjusted by means of different pilot pressure settings, enabling different power mode settings.

If the pilot pressure signal is then adjusted by means of an external power limiting control, the total hydraulic power consumption of all users can be adapted to the available drive power from the engine.

The pilot pressure used for power control is generated by an external control element that is not a component part of the AA11VO (e.g. see also data sheet RE 95310, Electronic Load Limiting Control, LLC).

LG1 Negative power override

Power control with negative override, LG1: the force resulting from the pilot pressure is acting against the mechanical adjustment spring of the power control.

Increasing the pilot pressure reduces the power setting.

Circuit diagram LG1

Size 40 to 145

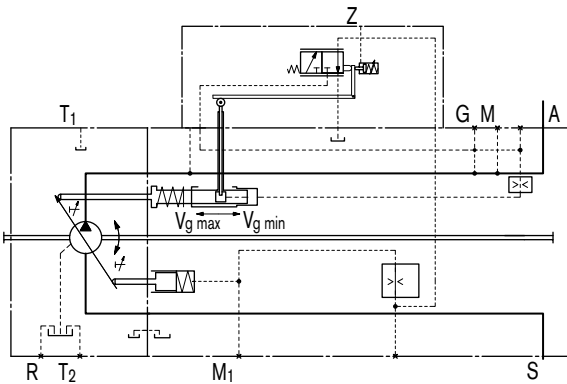

Size 190 to 260

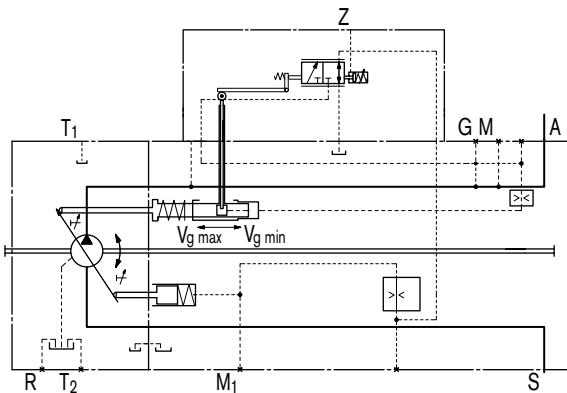

LG2 Positive power override

Power control with positive override, LG2: the force resulting from the pilot pressure is additive the mechanical adjustment spring of the power control.

An increase in pilot pressure increases the power output.

Circuit diagram LG2

Size 40 to 145

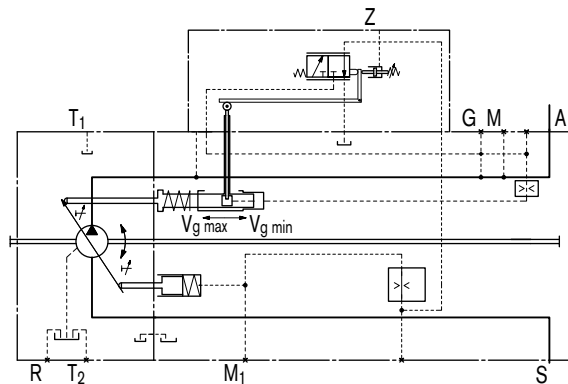

Size 190 to 260

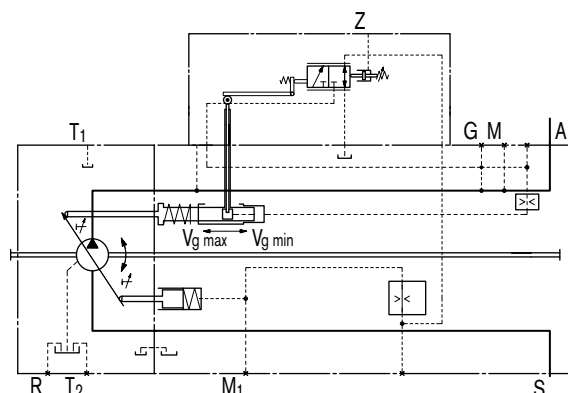

LR – Power control

LE1/2 Electric override (negative)

Contrary to hydraulic power control override, the basic power setting is reduced by an electric pilot current applied to a proportional solenoid. The resulting force is acting against the mechanical power control adjustment spring.

The mechanically adjusted basic power setting can be varied by means of different control current settings.

Increase in current = decrease in power

If the pilot current signal is adjusted by a load limiting control the power consumption of all actuators will be reduced to match the available power from the diesel engine.

A 12V (LE1) or 24V (LE2) supply is required for the control of the proportion solenoid.

Technical data - Solenoids

	LE1	LE2
Voltage	12 V (±20 %)	24 V (±20 %)
Control current		
Start of control	400 mA	200 mA
End of control	1200 mA	600 mA
Limiting current	1.54 A	0.77 A
Nominal resistance (at 68 °F (20 °C))	5.5 Ω	22.7 Ω
Dither frequency	100 Hz	100 Hz
Actuated time	100 %	100 %
Type of protection	see connector version, page 60	

Circuit diagram LE1/2

Size 40 to 145

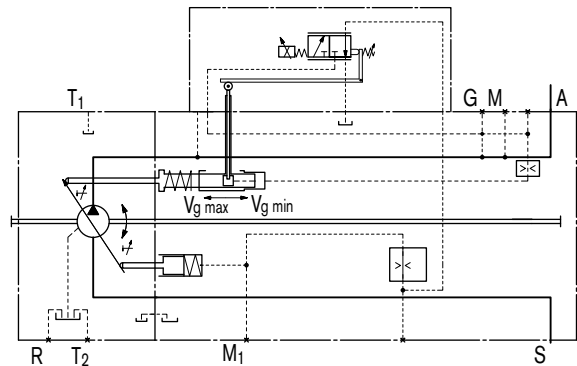

Size 190 to 260

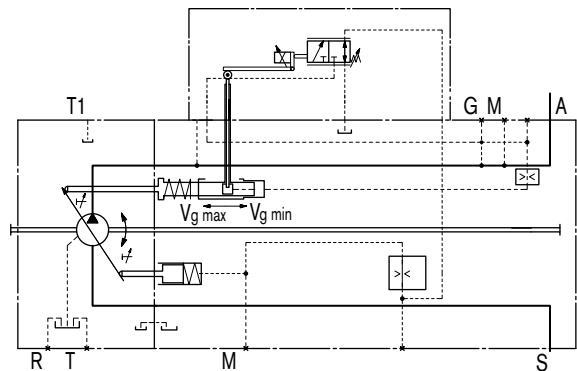

Overview of power overrides

Effect of power overrides at rising pressure or current

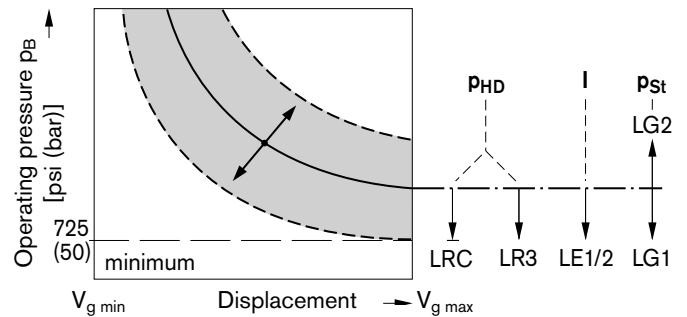

LR – Power control

LRD Power control with pressure cut-off

The pressure cut-off corresponds to a pressure control which adjusts the pump displacement back to $V_{g\ min}$, when the pressure setting is reached.

This function overrides the power control, i.e. below the preset pressure value, the power function is effective.

The pressure cut-off function is integrated into the pump control module and is preset to a specified value at the factory.

Setting range from 725 to 5100 psi (50 to 350 bar)

Characteristic LRD

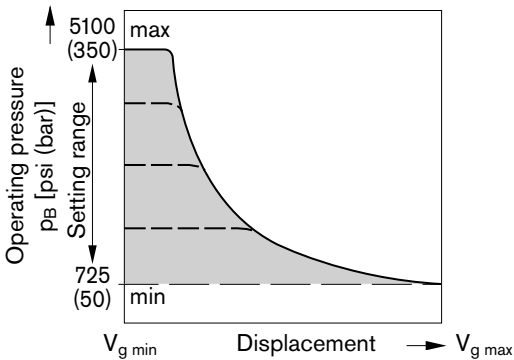

Circuit diagram LRD

Size 40 to 145

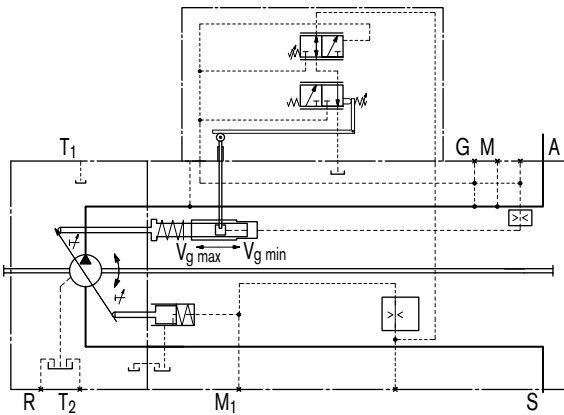

Size 190 to 260

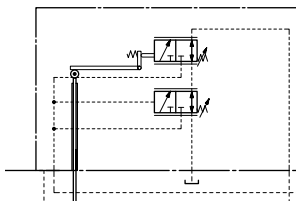

LRE Power control with pressure cut-off, 2-stage

By connecting an external pilot pressure to port Y, the basic value of the pressure cut-off can be increased by 725+290 psi (50 +20 bar) and a 2nd pressure setting implemented.

This value is usually above the primary pressure relief valve setting and therefore disables the pressure cut-off function.

The pressure signal at port Y must be between 290 and 725 psi (20 and 50 bar).

Characteristic LRE

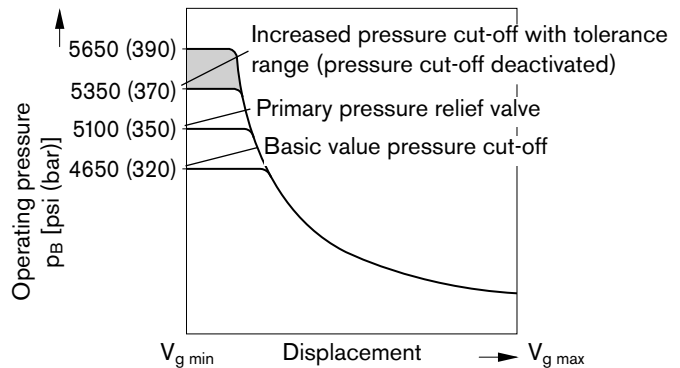

Circuit diagram LRE

Size 40 to 145

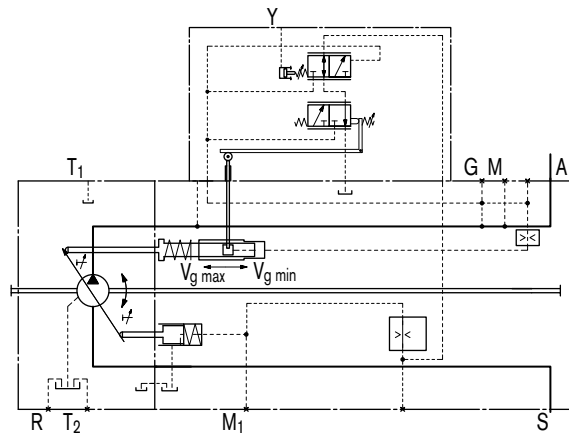

Size 190 to 260

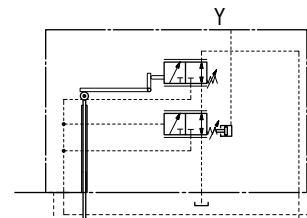

LRG Power control with pressure cut-off, hydraulically remote controlled

See page 21 for description and characteristic (pressure control remote controlled, DRG)

LR – Power control

LRDS Power control with pressure cut-off and load sensing

The load sensing control is a flow control option that operates as a function of the load pressure to regulate the pump displacement to match the actuator flow requirement.

The flow depends here on the cross section of the external sensing orifice (1) fitted between the pump outlet and the actuator. The flow is independent of the load pressure below the power curve and the pressure cut-off setting and within the control range of the pump.

The sensing orifice is usually a separately arranged load sensing directional valve (control block). The position of the directional valve piston determines the opening cross section of the sensing orifice and thus the flow of the pump.

The load sensing control compares pressure before and after the sensing orifice and maintains the pressure drop across the orifice (differential pressure Δp) and with it the pump flow constant.

If the differential pressure Δp increases at the sensing orifice, the pump is swivelled back (towards $V_{g \text{ min}}$), and, if the differential pressure Δp decreases, the pump is swivelled out (towards $V_{g \text{ max}}$) until the pressure drop across the sensing orifice in the valve is restored.

$$\Delta p_{\text{orifice}} = p_{\text{pump}} - p_{\text{actuator}}$$

The setting range for Δp is between 200 psi and 365 psi (14 bar and 25 bar).

The standard differential pressure setting is 260 psi (18 bar). (Please state in clear text when ordering).

The stand-by pressure in zero stroke operation (sensing orifice plugged) is slightly above the Δp setting.

In a standard LS system the pressure cut-off is integrated in the pump control. In a LUDV (flow sharing) system the pressure cut-off is integrated in the LUDV control block.

(1) The sensing orifice (control block) is not included in the pump supply.

Circuit diagram LRDS

Size 40 to 145

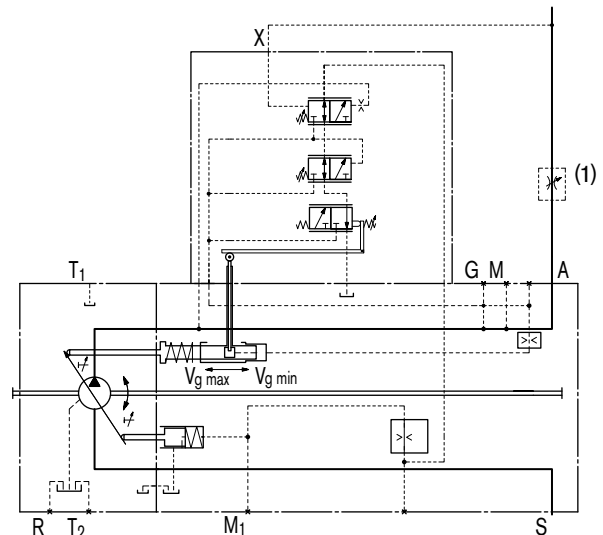

Size 190 to 260

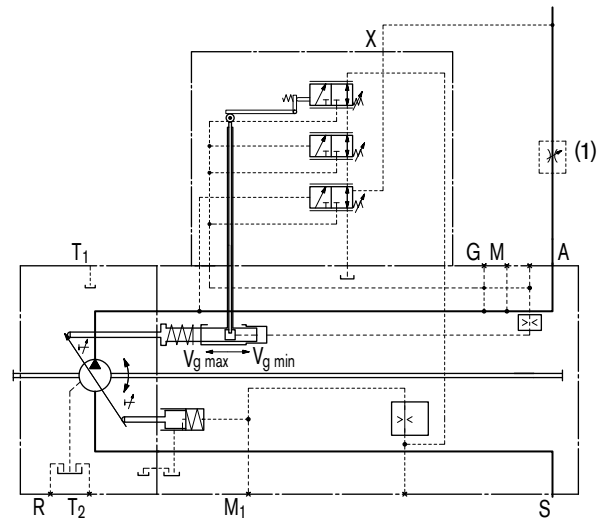

Characteristic LRDS

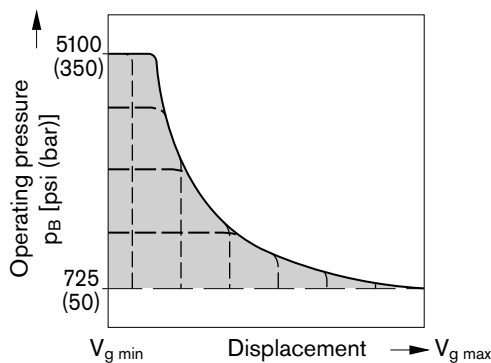

LR – Power control

LRS2 Power control with load sensing, electric override

This control option adds a proportional solenoid to override to the mechanically set load sensing pressure. The pressure differential change is proportional to the solenoid current.

Increasing current = smaller Δp -setting

See following characteristic for details (example). Please consult us during the project planning phase. For solenoid specification, see page 12 (LE2)

Characteristic LRS2

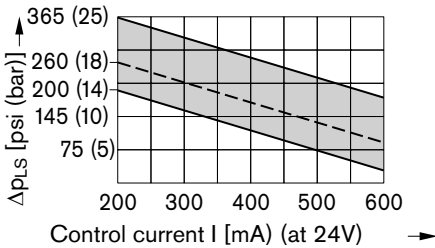

Circuit diagram LRS2

Size 40 to 145

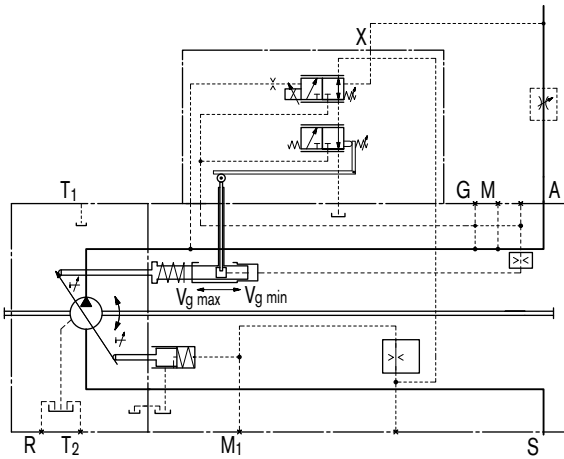

Size 190 to 260

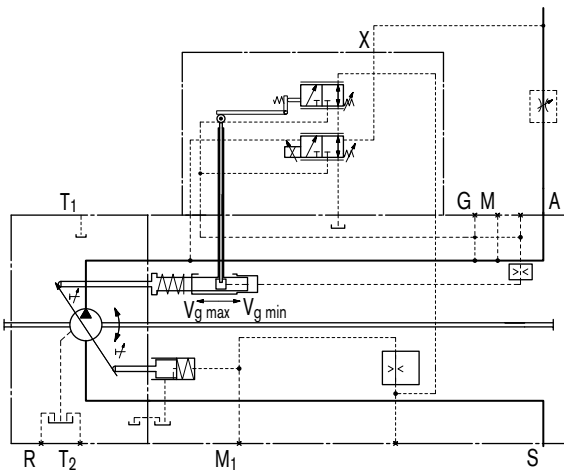

LRS5 Power control with load sensing, hydraulic override

This control option adds an external proportional pilot pressure signal (to port Z) to override the mechanically set load sensing pressure.

Increasing pilot pressure = smaller Δp -setting

See following characteristic for details (example). Please consult us during the project planning phase.

Characteristic LRS5

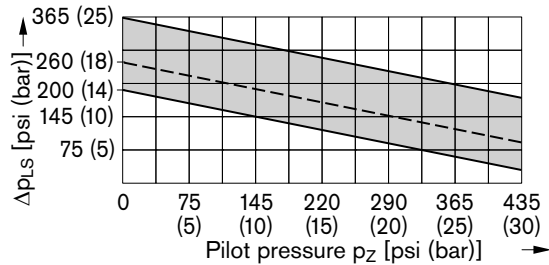

Circuit diagram LRS5

Size 40 to 145

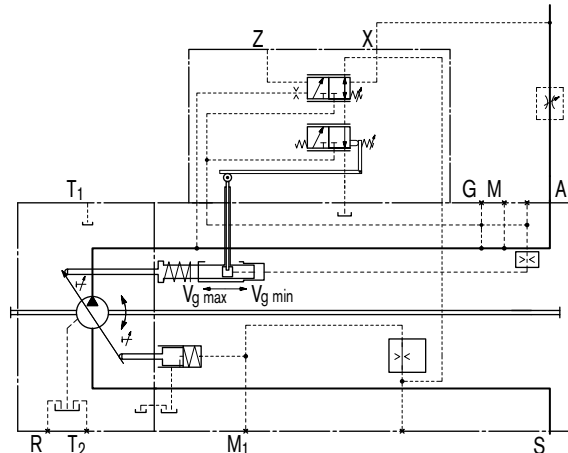

Size 190 to 260

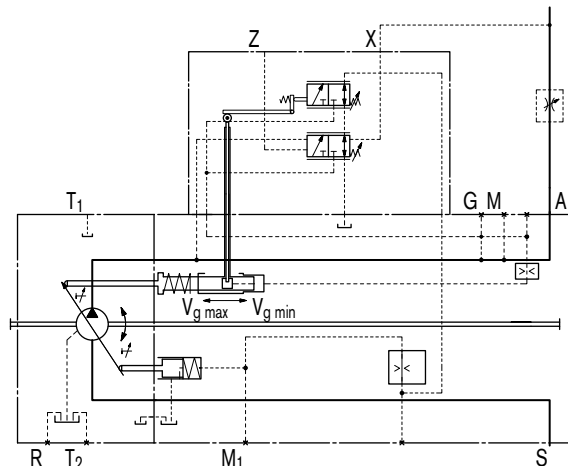

LR – Power control

LR... Power control with stroke limiter

The stroke limiter can be used to vary or limit the displacement of the pump continuously over the whole control range. The displacement is set in LRH with the pilot pressure p_{St} (maximum 580 psi (40 bar)) applied to port Y or in LRU by the control current applied to the proportional solenoid. A DC current of 12V (U1) or 24V (U2) is required to control the proportional solenoid.

The power control overrides the stroke limiter control, i.e. below the hyperbolic power characteristic, the displacement is controlled by the control current or pilot pressure. When exceeding the power characteristic with a set flow or load pressure, the power control overrides and reduces the displacement following the hyperbolic characteristic.

To permit operation of the pump displacement control from its starting position $V_{g\ max}$ to $V_{g\ min}$, a minimum control pressure of 435 psi (30 bar) is required for the electric stroke limiter LRU1/2 and the hydraulic stroke limiter LRH2/6.

The required control pressure is taken either from the load pressure, or from the externally applied control pressure at the G port.

To ensure functioning of the stroke limiter even at low operating pressure, port G must be supplied with external control pressure of approx. 435 psi (30 bar).

Note

If no external control pressure is connected at G, the shuttle valve must be removed.

Note

The spring return feature in the controller is not a safety device

The spool valve inside the controller can get stuck in an undefined position by internal contamination (contaminated hydraulic fluid, abrasion or residual contamination from system components). As a result, the axial piston unit can no longer supply the flow specified by the operator.

Check whether your application requires that remedial measures be taken on your machine in order to bring the driven consumer into a safe position (e.g. immediate stop).

LR – Power control

LRH1/5 Hydraulic stroke limiter (negative characteristic)

Control from $V_{g \max}$ to $V_{g \min}$

With increasing pilot pressure the pump swivels to a smaller displacement.

Start of control (at $V_{g \max}$), can be set from _____ 60 to 145 psi (4 to 10 bar)

State start of control in clear text in the order.

Starting position without control signal (pilot pressure): $V_{g \max}$

Characteristic H1

Increase in pilot pressure ($V_{g \max} - V_{g \min}$)
 $\Delta p = 365 \text{ psi (25 bar)}$

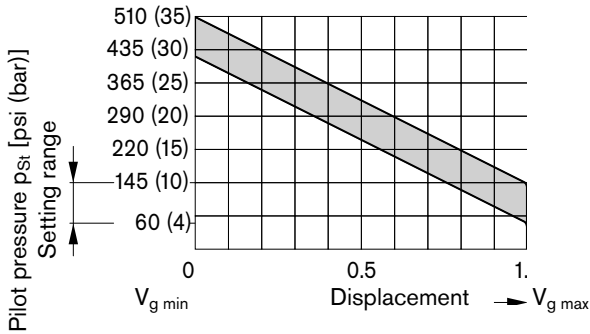

Characteristic H5

Increase in pilot pressure ($V_{g \max} - V_{g \min}$)
 $\Delta p = 145 \text{ psi (10 bar)}$

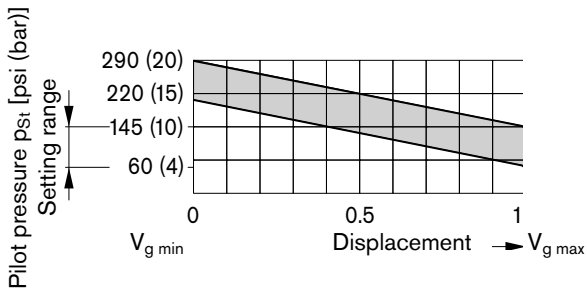

Circuit diagram LRH1/5

Size 40 to 145

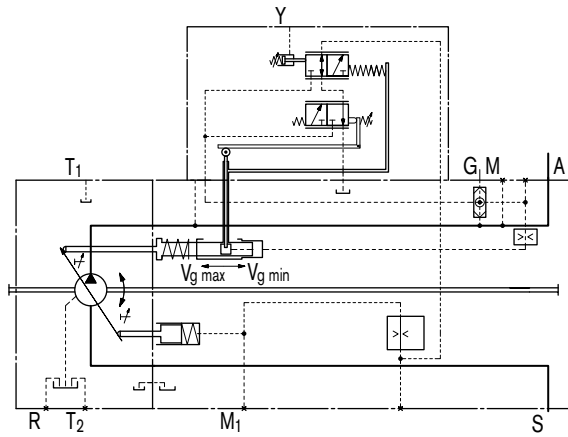

Size 190 to 260

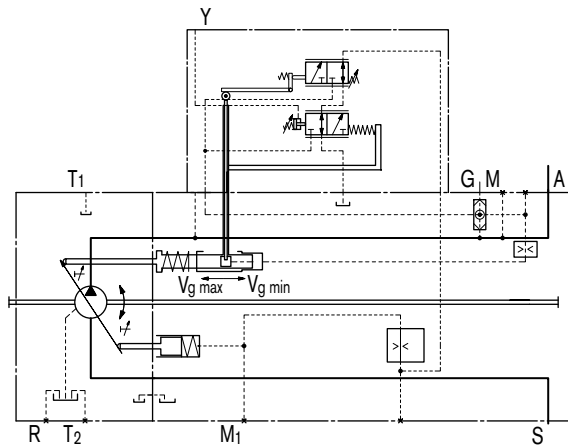

LR – Power control

LRH2/6 Hydraulic stroke limiter (positive characteristic)

Control from $V_{g \min}$ to $V_{g \max}$

With increasing pilot pressure the pump swivels to a higher displacement.

Start of control (at $V_{g \min}$), can be set _____ from 60 to 145 psi (4 to 10 bar)

State start of control in clear text in the order.

Starting position without control signal (pilot pressure):

- at operating pressure and external control pressure < 435 psi (30 bar): $V_{g \max}$
- at operating pressure or external control pressure > 435 psi (30 bar): $V_{g \min}$

Characteristic H2

Increase in pilot pressure ($V_{g \min} - V_{g \max}$)

$\Delta p = 365 \text{ psi (25 bar)}$

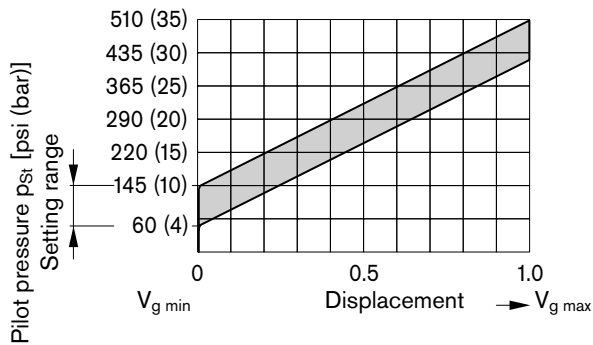

Characteristic H6

Increase in pilot pressure ($V_{g \min} - V_{g \max}$)

$\Delta p = 145 \text{ psi (10 bar)}$

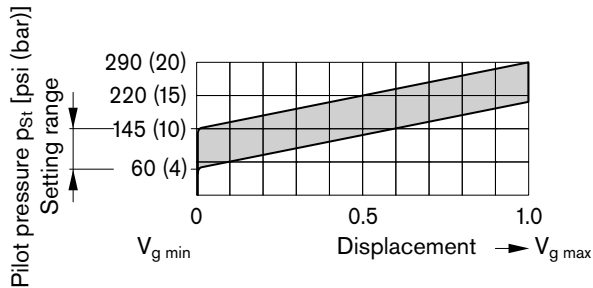

Circuit diagram LRH2/6

Size 40 to 145

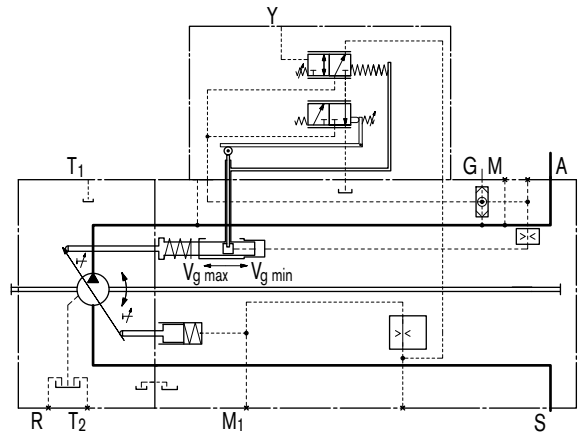

Size 190 to 260

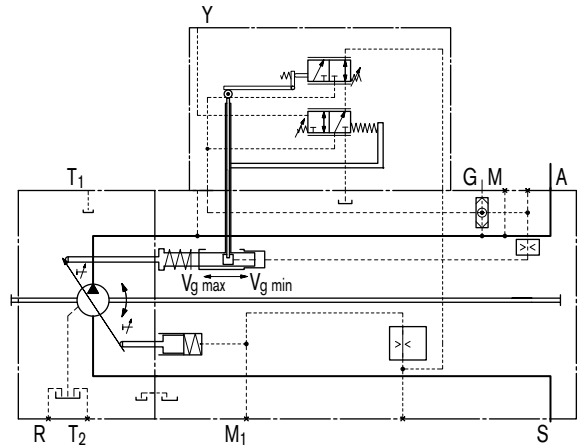

LR – Power control

LRU1/2 Electric stroke limiter (positive characteristic)

Control from $V_{g \min}$ to $V_{g \max}$

With increasing control current the pump swivels to a higher displacement.

Technical data - solenoids

	LRU1	LRU2
Voltage	12 V ($\pm 20\%$)	24 V ($\pm 20\%$)
Control current		
Start of control at $V_{g \max}$	400 mA	200 mA
End of control at $V_{g \min}$	1200 mA	600 mA
Limiting current	1.54 A	0.77 A
Nominal resistance (at 68 °F (20 °C))	5.5 Ω	22.7 Ω
Dither frequency	100 Hz	100 Hz
Actuated time	100 %	100 %
Type of protection	see connector version, page 60	

Starting position without control signal (control current):

- at operating pressure and external control pressure < 435 psi (30 bar): $V_{g \max}$
- at operating pressure or external control pressure > 435 psi (30 bar): $V_{g \min}$

The following electronic controllers and amplifiers are available for actuating the proportional solenoids (see also www.boschrexroth.com/mobile-electronics):

- BODAS controller RC
 - Series 20 _____ RE 95200
 - Series 21 _____ RE 95201
 - Series 22 _____ RE 95202
 - Series 30 _____ RE 95203
 and application software
- Analog amplifier RA _____ RE 95230

Characteristic LRU1/2

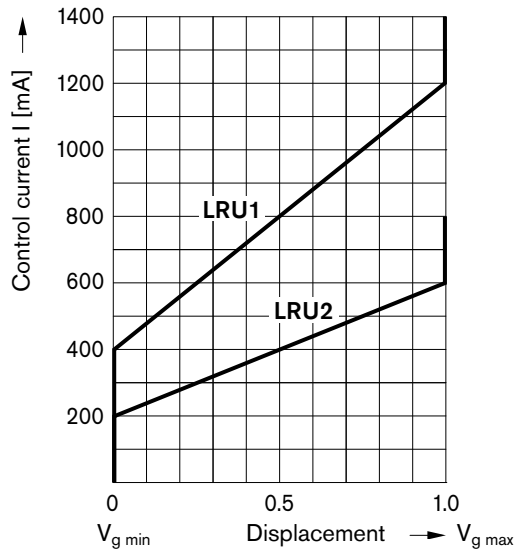

Circuit diagram LRU1/2

Size 40 to 145

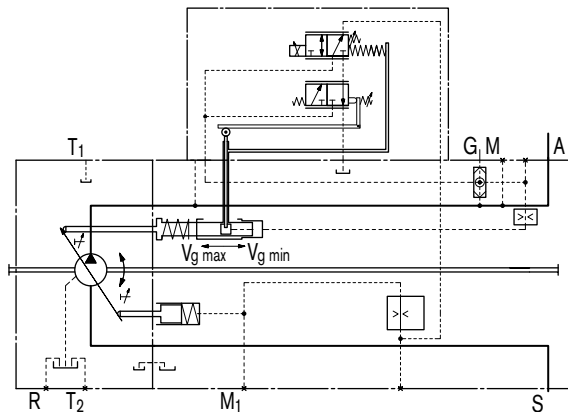

Size 190 to 260

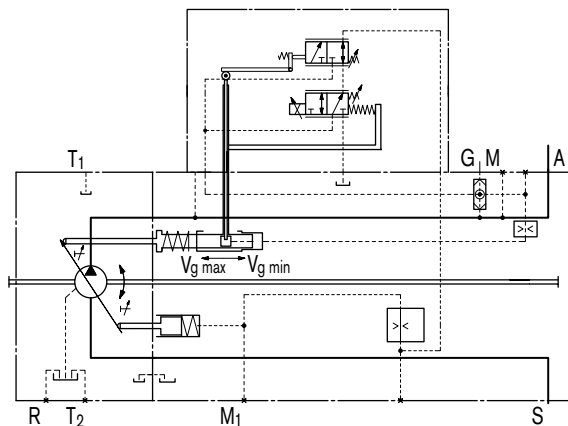

DR – Pressure control

DR Pressure control

The pressure control keeps the pressure in a hydraulic system constant within its control range even under varying flow conditions. The variable pump only moves as much hydraulic fluid as is required by the actuators. If the operating pressure exceeds the setpoint set at the integral pressure control valve, the pump displacement is automatically swivelled back until the pressure deviation is corrected.

Starting position in depressurized state: $V_{g \max}$

Setting range from 725 to 5100 psi (50 to 350 bar).

Characteristic: DR

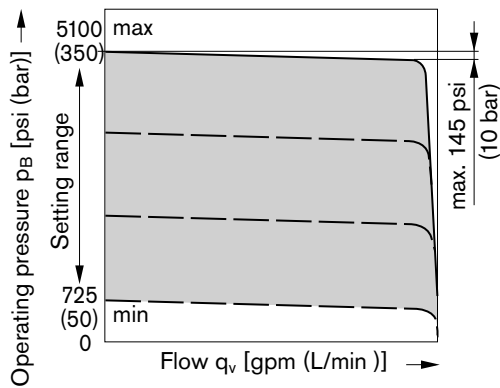

Circuit diagram DR

Size 40 to 145

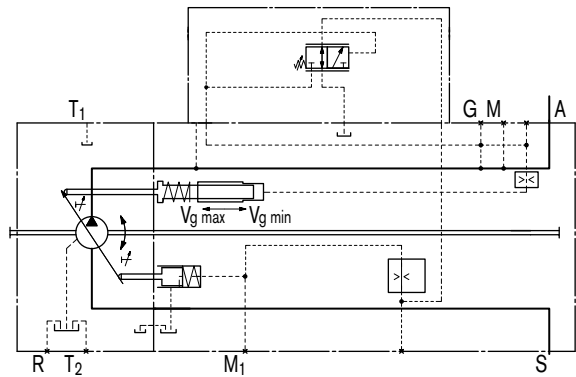

Size 190 to 260

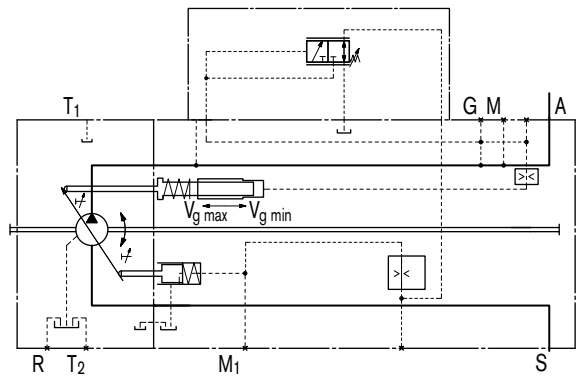

DR – Pressure control

DRS Pressure control with load sensing

The load sensing control is a flow control option that operates as a function of the load pressure to regulate the pump displacement to match the actuator flow requirement.

The flow depends here on the cross section of the external sensing orifice (1) fitted between the pump outlet and the actuator. The flow is independent of the load pressure below the pressure cut-off setting and within the control range of the pump.

The sensing orifice is usually a separately arranged load sensing directional valve (control block). The position of the directional valve piston determines the opening cross section of the sensing orifice and thus the flow of the pump.

The load sensing control compares pressure before and after the sensing orifice and maintains the pressure drop across the orifice (differential pressure Δp) and with it the pump flow constant.

If the differential pressure Δp increases, the pump is swivelled back (towards $V_{g \text{ min}}$) and, if the differential pressure Δp decreases the pump is swivelled out (towards $V_{g \text{ max}}$) until the pressure drop across the sensing orifice in the valve is restored.

$$\Delta p_{\text{orifice}} = p_{\text{pump}} - p_{\text{actuator}}$$

The setting range for Δp is between 200 psi and 360 psi (14 bar and 25 bar).

The standard differential pressure setting is 260 psi (18 bar). (Please state in clear text when ordering).

The stand-by pressure in zero stroke operation (sensing orifice plugged) is slightly above the Δp setting.

(1) The sensing orifice (control block) is not included in the pump supply.

Characteristic: DRS

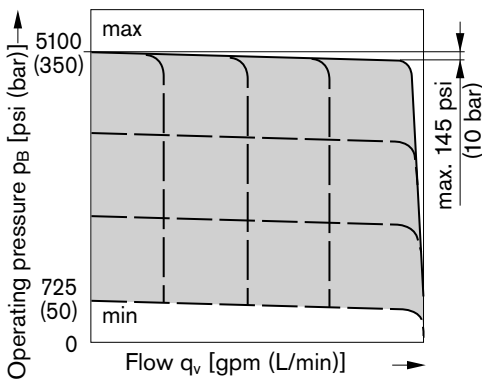

Circuit diagram DRS

Size 40 to 145

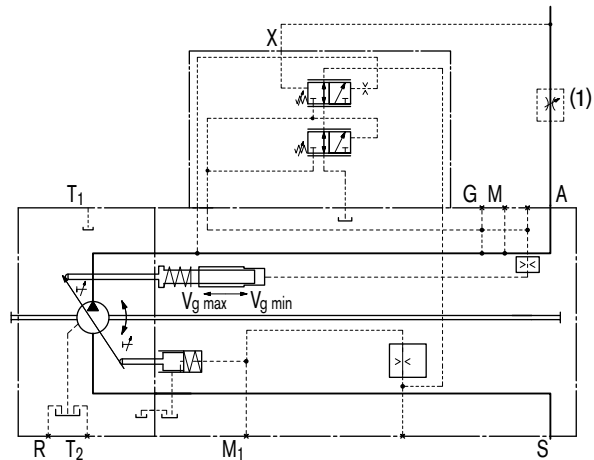

Size 190 to 260

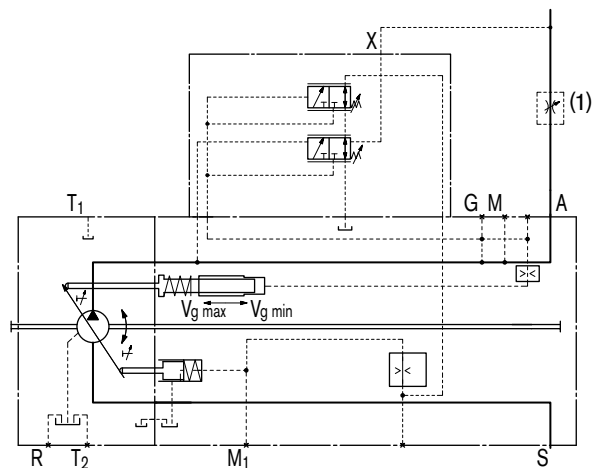

DR – Pressure control

DRG Pressure control, remote controlled

The remote control pressure cut-off regulator permits the adjustment of the pressure setting by a remotely installed pressure relief valve (1). Pilot flow for this valve is provided by a fixed orifice in the control module.

Setting range from 725 to 5100 psi (50 to 350 bar).

In addition the pump can be unloaded into a standby pressure condition by an externally installed 2/2-way directional valve (2).

Both functions can be used individually or in combination (see circuit diagram).

The external valves are not included in the pump supply.

As a separate pressure relief valve (1) we recommend:

DBDH 6 (manual control), see RE 25402

Characteristic: DRG

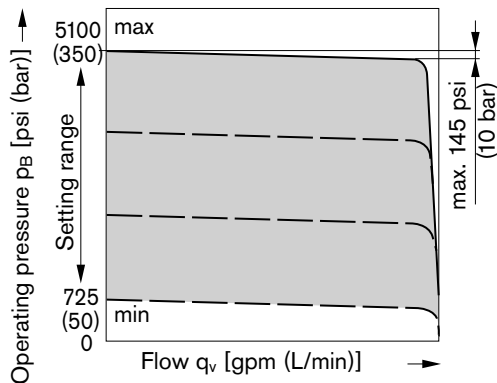

Note

The remote controlled pressure cut-off is also possible in combination with LR, HD and EP.

Circuit diagram DRG

Size 40 to 145

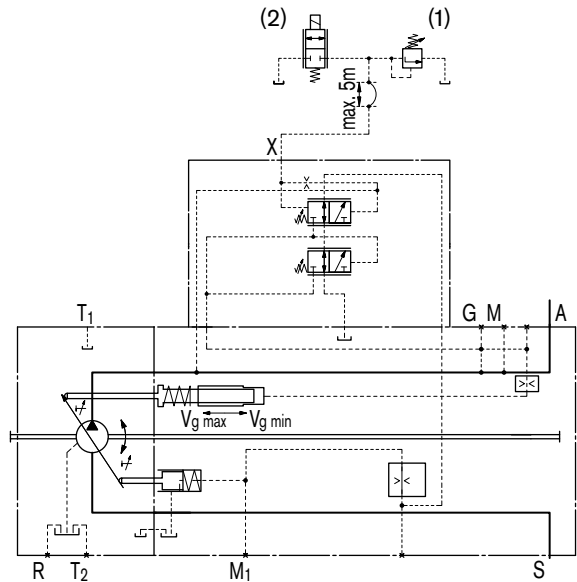

Size 190 to 260

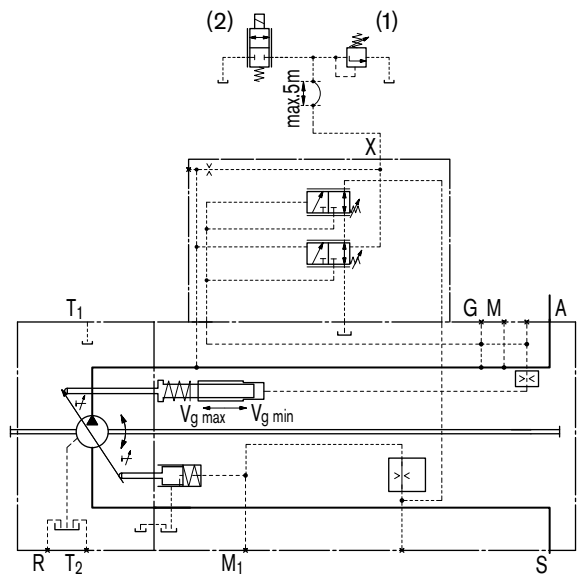

DR – Pressure control

DRL Pressure control for parallel operation

The pressure control DRL is suitable for pressure control of several axial piston pumps AA11VO in parallel operation pumping into a common pressure header.

The parallel pressure control has a pressure rise characteristic of approx. 220 psi (15 bar) from $q_{v \max}$ to $q_{v \min}$. The pump regulates therefore to a pressure dependent swive angle. This results in stable control behavior, without the need of "staging" the individual pump compensators.

With the externally installed pressure relief valve (1) the nominal pressure setting of all pumps connected to the system is adjusted to the same value.

Setting range from 725 to 5100 psi (50 to 350 bar).

Each pump can be individually unloaded from the system by a separately installed 3/2-way directional valve (2).

The check valves (3) in the service line (port A) or control line (port X) must be provided generally.

The external valves are not included in the pump supply.

As a separate pressure relief valve (1) we recommend:

DBDH 6 (manual control), see RE 25402

Characteristic DRL

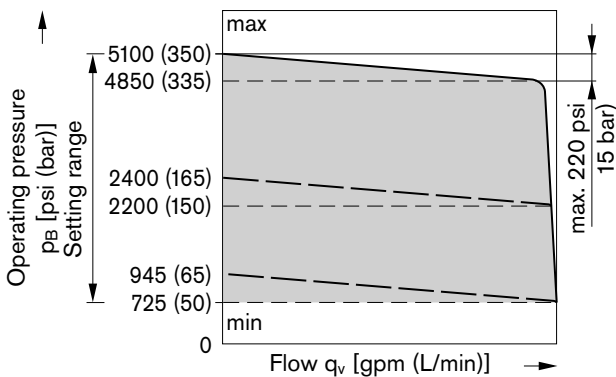

Circuit diagram DRL

Size 40 to 145

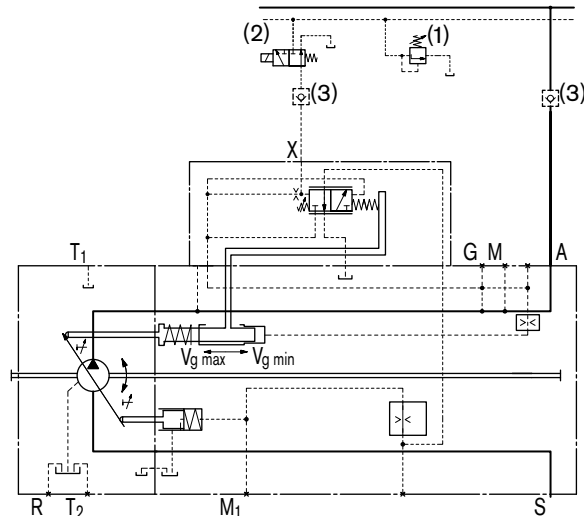

Size 190 to 260

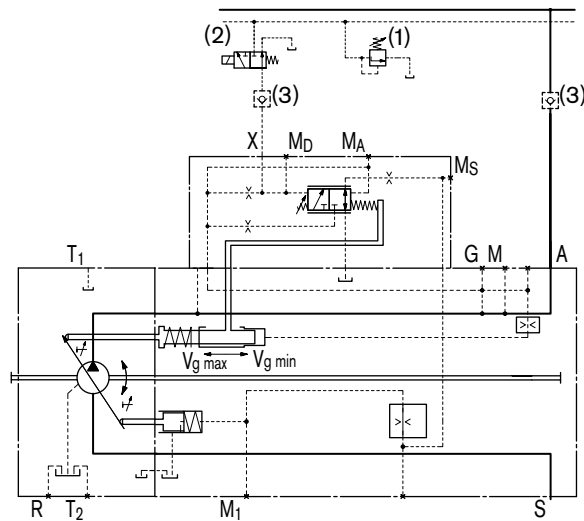

HD – Hydraulic control, pilot-pressure related

With the pilot-pressure related control the pump displacement is adjusted in proportion to the pilot pressure applied to port Y. Maximum permissible pilot pressure $p_{St\ max} = 580$ psi (40 bar)

Control from $V_{g\ min}$ to $V_{g\ max}$.

With increasing pilot pressure the pump swivels to a higher displacement.

Start of control (at $V_{g\ min}$), can be set from 60 to 145 psi (4 to 10 bar)

State start of control in clear text in the order.

Starting position without control signal (pilot pressure):

- at operating pressure and external control pressure < 435 psi (30 bar): $V_{g\ max}$
- at operating pressure or external control pressure > 435 psi (30 bar): $V_{g\ min}$

A control pressure of 435 psi (30 bar) is required to swivel the pump from its starting position $V_{g\ max}$ to $V_{g\ min}$.

The required control pressure is taken either from the load pressure, or from the externally applied control pressure at the G port.

To ensure the control even at low operating pressure < 435 psi (30 bar) the port G must be supplied with an external control pressure of approx. 435 psi (30 bar).

Note

If no external control pressure is connected at G, the shuttle valve must be removed.

Note

The spring return feature in the controller is not a safety device

The spool valve inside the controller can get stuck in an undefined position by internal contamination (contaminated hydraulic fluid, abrasion or residual contamination from system components). As a result, the axial piston unit can no longer supply the flow specified by the operator.

Check whether your application requires that remedial measures be taken on your machine in order to bring the driven consumer into a safe position (e.g. immediate stop).

Characteristic HD1

Increase in pilot pressure $V_{g\ min}$ to $V_{g\ max}$
 $\Delta p = 145$ psi (10 bar)

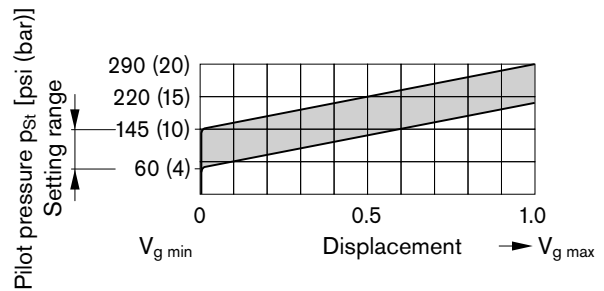

Characteristic HD2

Increase in pilot pressure $V_{g\ min}$ to $V_{g\ max}$
 $\Delta p = 365$ psi (25 bar)

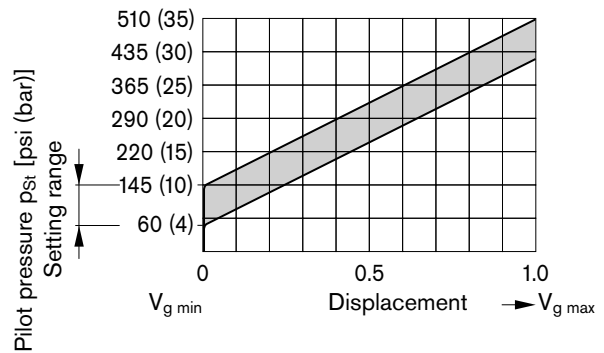

Circuit diagram HD

Size 40 to 260

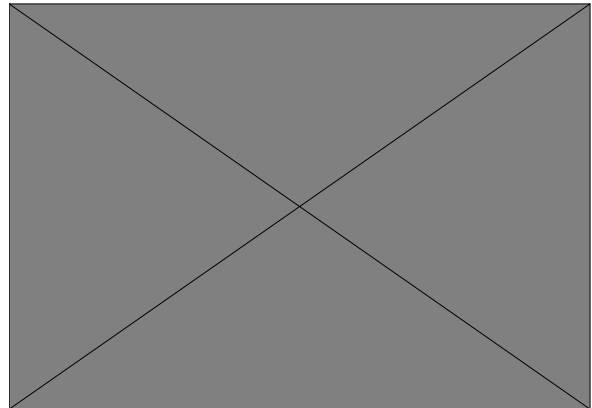

HD – Hydraulic control, pilot-pressure related

HD.D Hydraulic control with pressure cut-off

The pressure cut-off corresponds to a pressure control which adjusts the pump displacement back to $V_{g \text{ min}}$ when the pressure setting is reached.

This function overrides the HD control, i.e. the pilot-pressure related displacement control is functional below the pressure setting.

The pressure cut-off function is integrated into the pump control module and is preset to a specified value at the factory.

Setting range from 725 to 5100 psi (50 to 350 bar).

Pressure cut-off characteristic D

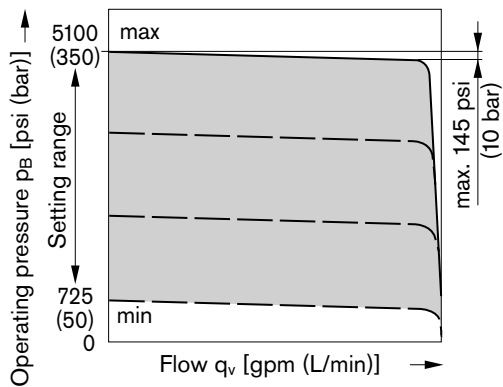

Circuit diagram HD.D

Size 40 to 145

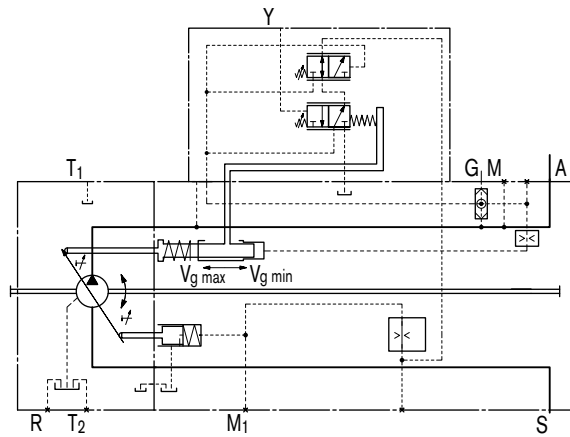

Size 190 to 260

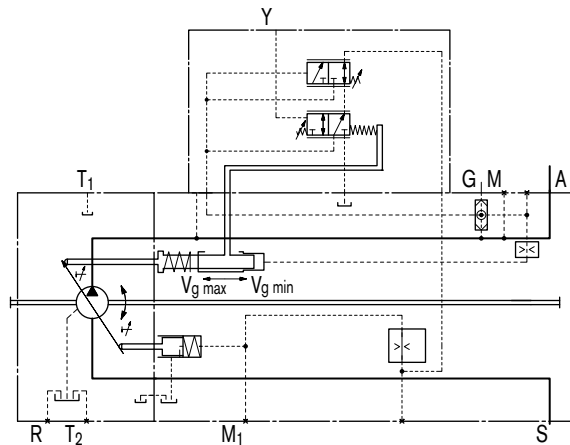

EP – Electric control with proportional solenoid

With the electric control with proportional solenoid, the pump displacement is adjusted proportionally to the solenoid current, resulting in a magnetic control force, acting directly onto the control spool that pilots the pump control piston.

Control from $V_{g \text{ min}}$ to $V_{g \text{ max}}$

With increasing control current the pump swivels to a higher displacement.

Starting position without control signal (control current):

- at operating pressure and external control pressure < 435 psi (30 bar): $V_{g \text{ max}}$
- at operating pressure or external control pressure > 435 psi (30 bar): $V_{g \text{ min}}$

A control pressure of 435 psi (30 bar) is required to swivel the pump from its starting position $V_{g \text{ max}}$ to $V_{g \text{ min}}$.

The required control pressure is taken either from the load pressure, or from the externally applied control pressure at port G.

To ensure the control even at low operating pressure < 435 psi (30 bar) the port G must be supplied with an external control pressure of approx. 435 psi (30 bar).

Note

If no external control pressure is connected at G, the shuttle valve must be removed.

Note

Install pump with EP control in the oil tank only when using mineral hydraulic oils and an oil temperature in the tank of maximum 180 °F (80 °C).

The following electronic control units and amplifiers are available for actuating the proportional solenoids (see also www.boschrexroth.com/mobileelektronik):

- BODAS controller RC
 - Series 20 _____ RE 95200
 - Series 21 _____ RE 95201
 - Series 22 _____ RE 95202
 - Series 30 _____ RE 95203
 and application software
- Analog amplifier RA _____ RE 95230

Note

The spring return feature in the controller is not a safety device

The spool valve inside the controller can get stuck in an undefined position by internal contamination (contaminated hydraulic fluid, abrasion or residual contamination from system components). As a result, the axial piston unit can no longer supply the flow specified by the operator.

Check whether your application requires that remedial measures be taken on your machine in order to bring the driven consumer into a safe position (e.g. immediate stop).

Technical data, solenoid at EP1, EP2

	EP1	EP2
Voltage	12 V (±20 %)	24 V (±20 %)
Control current		
Start of control at $V_{g \text{ min}}$	400 mA	200 mA
End of control at $V_{g \text{ max}}$	1200 mA	600 mA
Limiting current	1.54 A	0.77 A
Nominal resistance (at 68 °F (20 °C))	5.5 Ω	22.7 Ω
Dither frequency	100 Hz	100 Hz
Actuated time	100 %	100 %
Type of protection	see connector version, page 60	

Characteristic EP1/2

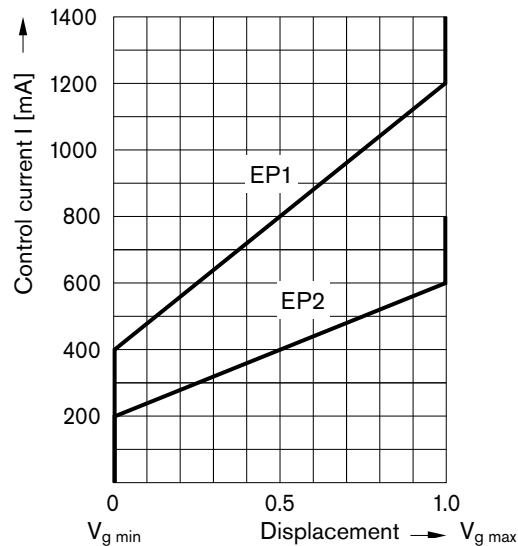

Circuit diagram EP1/2

Size 40 to 260

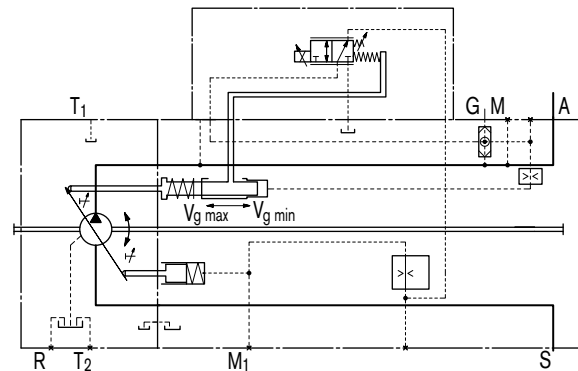

EP – Electric control with proportional solenoid

EP.D Electric control with pressure cut-off

The pressure cut-off corresponds to a pressure control which adjusts the pump displacement back to $V_{g \text{ min}}$ when the pressure setting is reached.

This function overrides the EP control, i.e. the control current related displacement control is functional below the pressure setting.

The valve for the pressure cut-off is integrated in the control case and is set to a fixed specified pressure value at the factory.

Setting range from 725 to 5100 psi (50 to 350 bar)

Pressure cut-off characteristic D

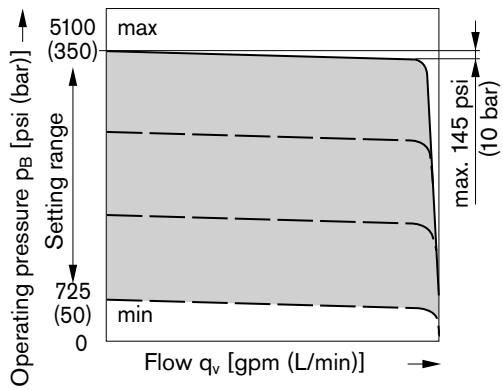

Circuit diagram EP.D

Size 40 to 145

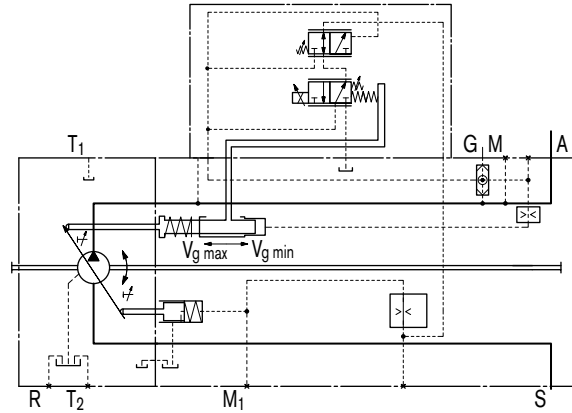

Size 190 to 260

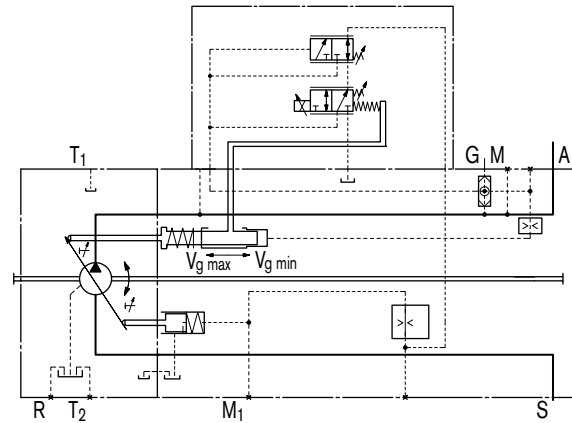

Notice

Dimensions size 40

Before finalizing your design,
please request a certified drawing.
Dimensions in inches and (millimeters).

LRDCS

Power control LR with pressure cut-off D, cross sensing control C and load sensing control S

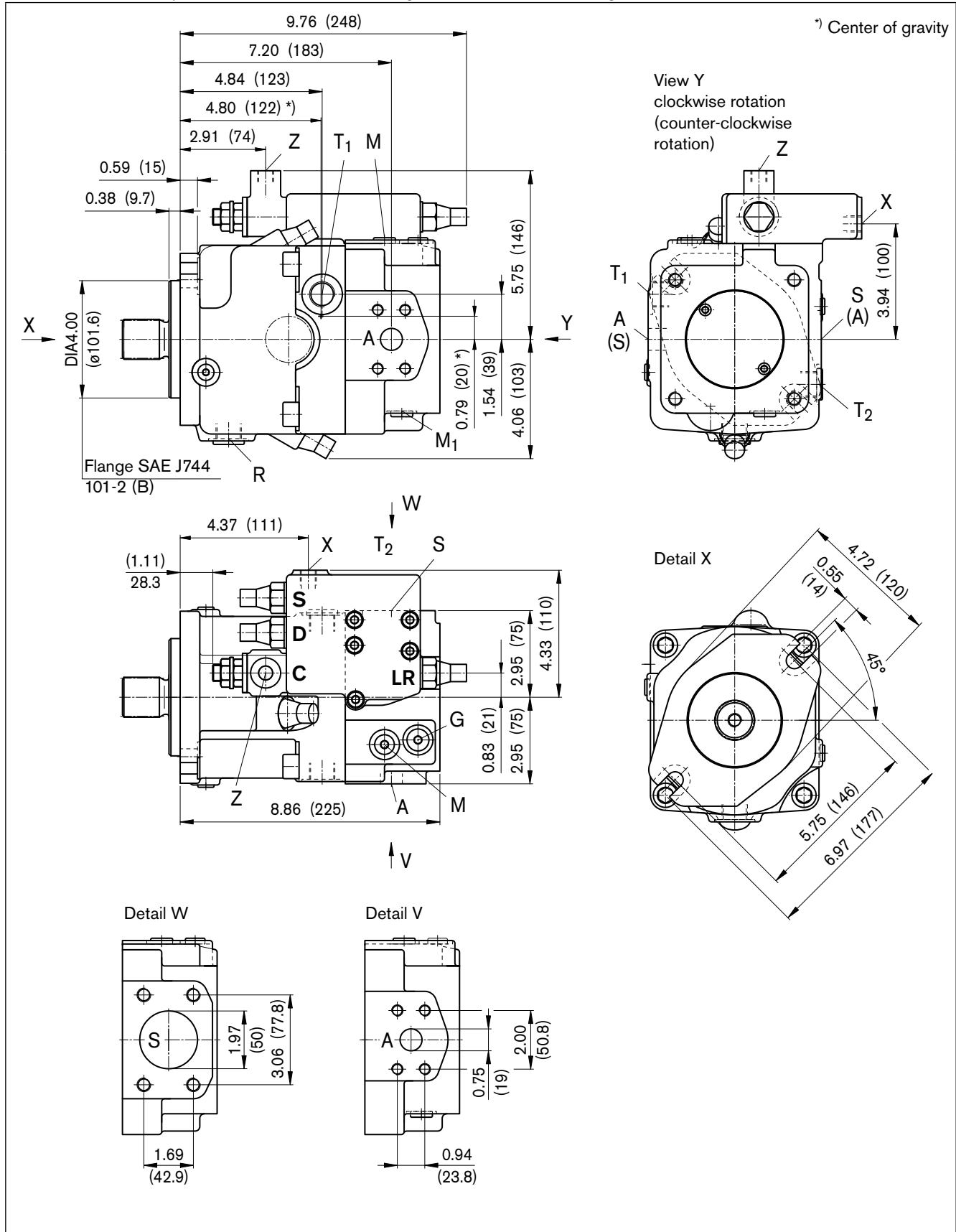

Dimensions size 40

Before finalizing your design, please request a certified drawing. Dimensions in inches and (millimeters).

Drive shaft

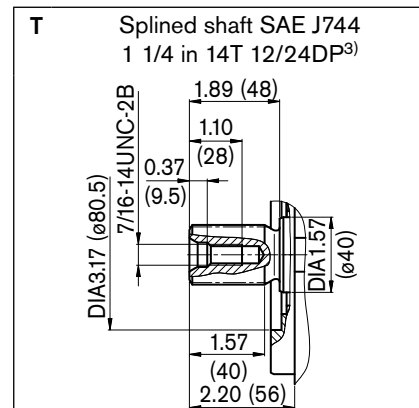
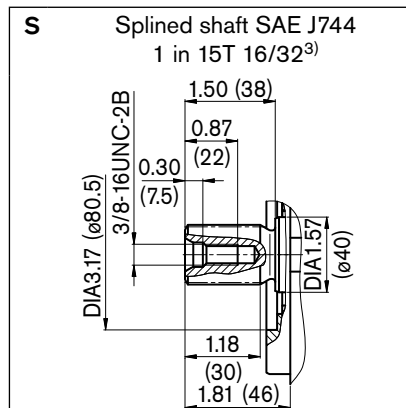
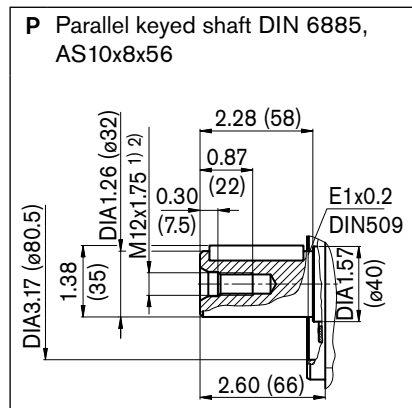

Ports

Designation	Function	Standard	Size ²⁾	Max. pressure [psi (bar)] ⁴⁾	State
A	Service line port Fixing thread	SAE J518 ISO 68	3/4 in 3/8in-16UNC-2B; 0.63 (16) deep	5800 (400)	O
S	Suction port Fixing thread	SAE J518 ISO 68	2 in 1/2in-13UNC-2B; 0.67 (17) deep	435 (30)	O
T ₁ , T ₂	Tank port	ISO 11926	7/8in-14UNF-2B; 0.55 (14) deep	145 (10)	5)
R	Air bleed	ISO 11926	7/8in-14UNF-2B; 0.55 (14) deep	145 (10)	X
M ₁	Measurement point, positioning chamber	ISO 11926	9/16in-18UNF-2B; 0.47 (12) deep	5800 (400)	X
M	Measurement point, service line port	ISO 11926	9/16in-18UNF-2B; 0.47 (12) deep	5800 (400)	X
X	Pilot pressure port in version with load sensing (S) and remote controlled pressure cut-off (G)	ISO 11926	9/16in-18UNF-2B; 0.47 (12) deep	5800 (400)	O
Y	Pilot pressure port in version with stroke limiter (H...), 2-stage pressure cut-off (E) and HD	ISO 11926	9/16in-18UNF-2B; 0.47 (12) deep	580 (40)	O
Z	Pilot pressure port in version with cross sensing (C) and power override (LR3) power override (LG1)	ISO 11926	9/16in-18UNF-2B; 0.47 (12) deep	5800 (400) 580 (40)	O
G	Port for control pressure (controller) in version with stroke limiter (H., U2), HD and EP with screw union GE10 - PLM (otherwise closed)	ISO 11926	9/16in-18UNF-2B; 0.47 (12) deep	580 (40)	O

1) Center bore according to DIN 332 (thread acc. to DIN 13)

2) For maximum tightening torque, please refer to general notes on page 64

3) ANSI B92.1a-1976, 30° pressure angle, flat root, side fit, tolerance class 5

4) Depending on adjustment data and operating pressure

5) Depending on installation position, T₁ or T₂ must be connected (see also page 61)

O= Open, must be connected (closed on delivery)

X= Closed (in normal operation)

Dimensions size 40

Before finalizing your design,
please request a certified drawing.
Dimensions in inches and (millimeters).

LRDH1/LRDH5

Power control with pressure cut-off and hydraulic stroke limiter
(negative characteristic)

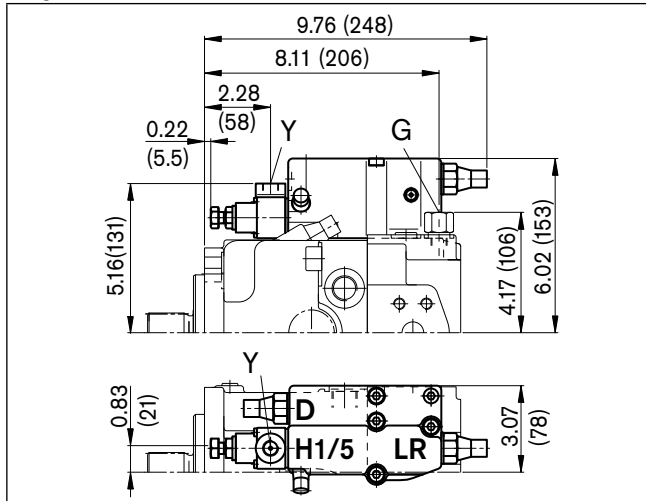

LRDH2/LRDH6

Power control with pressure cut-off and hydraulic stroke limiter
(positive characteristic)

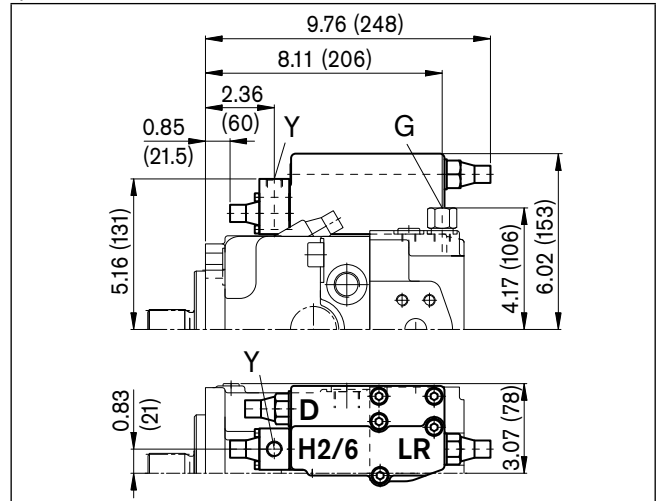

LRDU1/LRDU2

Power control with pressure cut-off and electric stroke limiter
(positive characteristic)

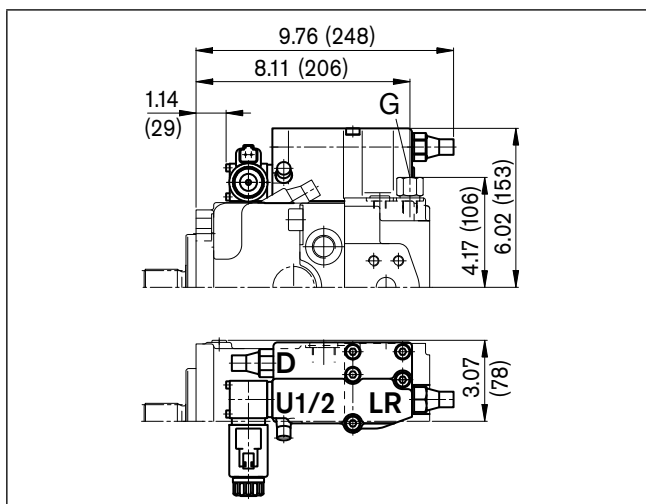

LR3DS

Power control with high-pressure related override,
pressure cut-off and load sensing control

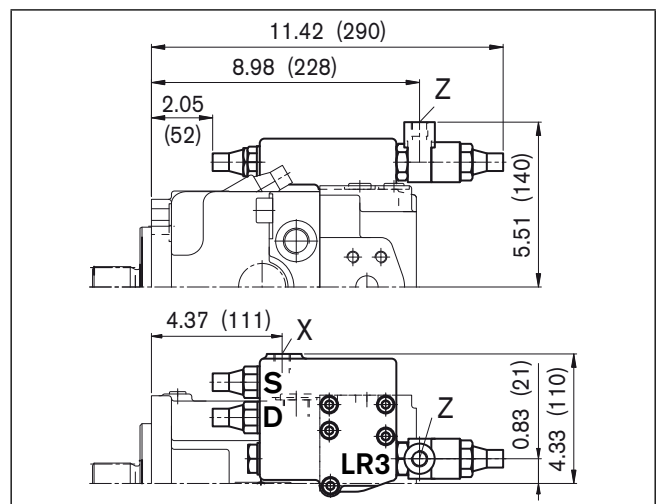

LG1E

Power control with pilot-pressure related override
(negative) and 2-stage pressure cut-off

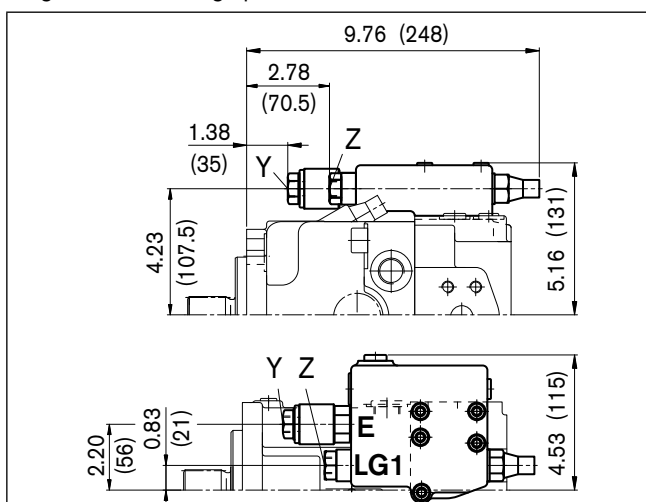

LG2E

Power control with pilot-pressure related override
(positive) and 2-stage pressure cut-off

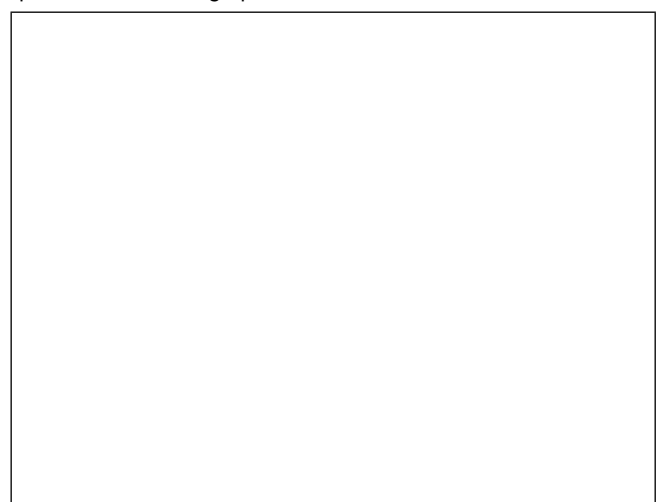

Dimensions size 40

Before finalizing your design,
please request a certified drawing.
Dimensions in inches and (millimeters).

HD1D/HD2D

Hydraulic control, pilot-pressure related with pressure cut-off

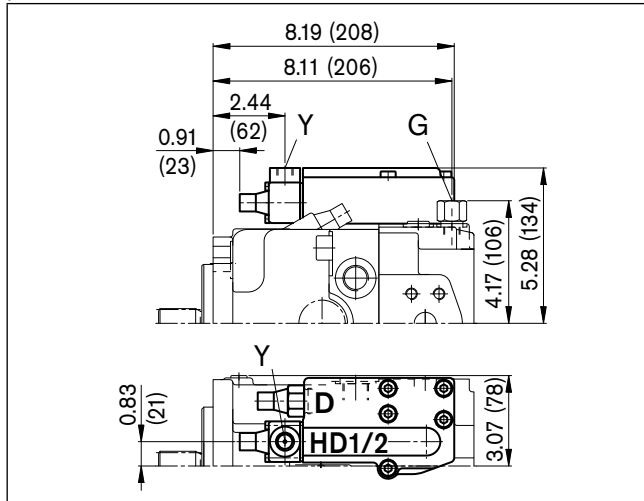

EP1D/EP2D

Electric control with proportional solenoid and pressure cut-off

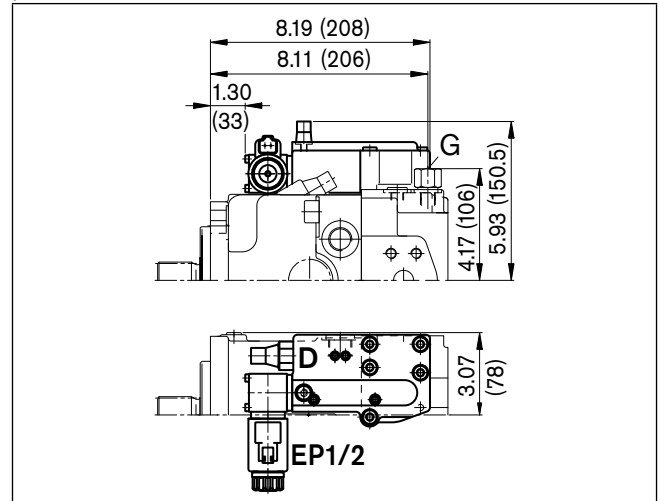

DRS/DRG

Pressure control with load sensing control
Pressure control remote controlled

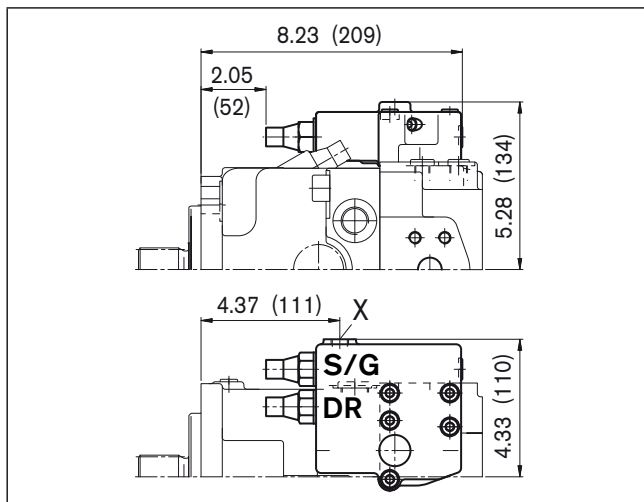

DRL

Pressure control for parallel operation

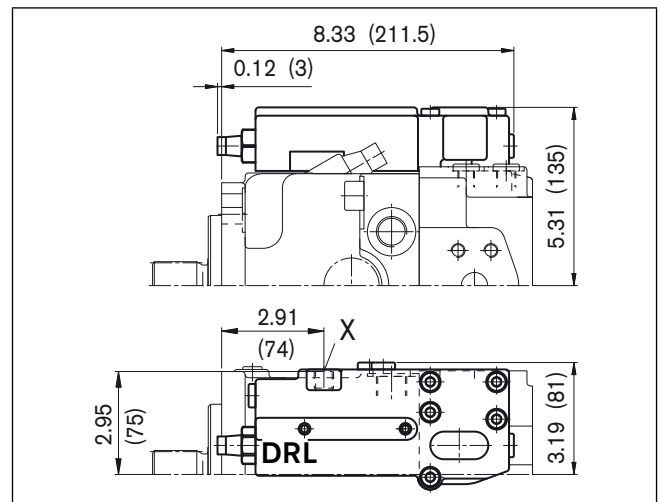

LE1S/LE2S

Power control with electric override (negative)
and load sensing control

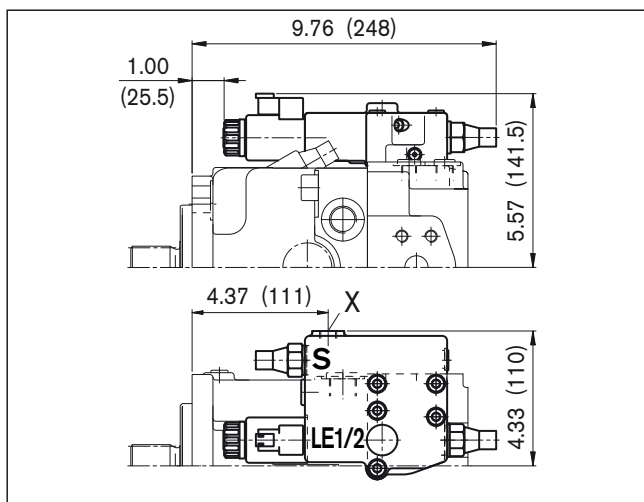

LE2S2/LE1S5/LE2S5

Power control with electric override (negative)
and load sensing control, override

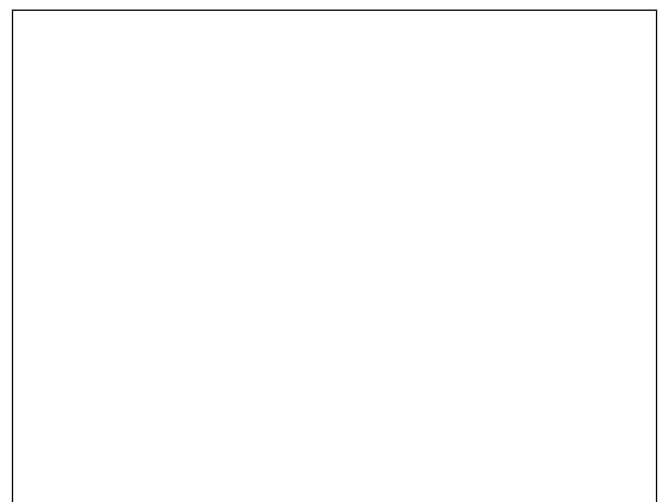

Dimensions size 60

Before finalizing your design,
please request a certified drawing.
Dimensions in inches and (millimeters).

LRDCS

Power control LR with pressure cut-off D, cross sensing control C and load sensing control S

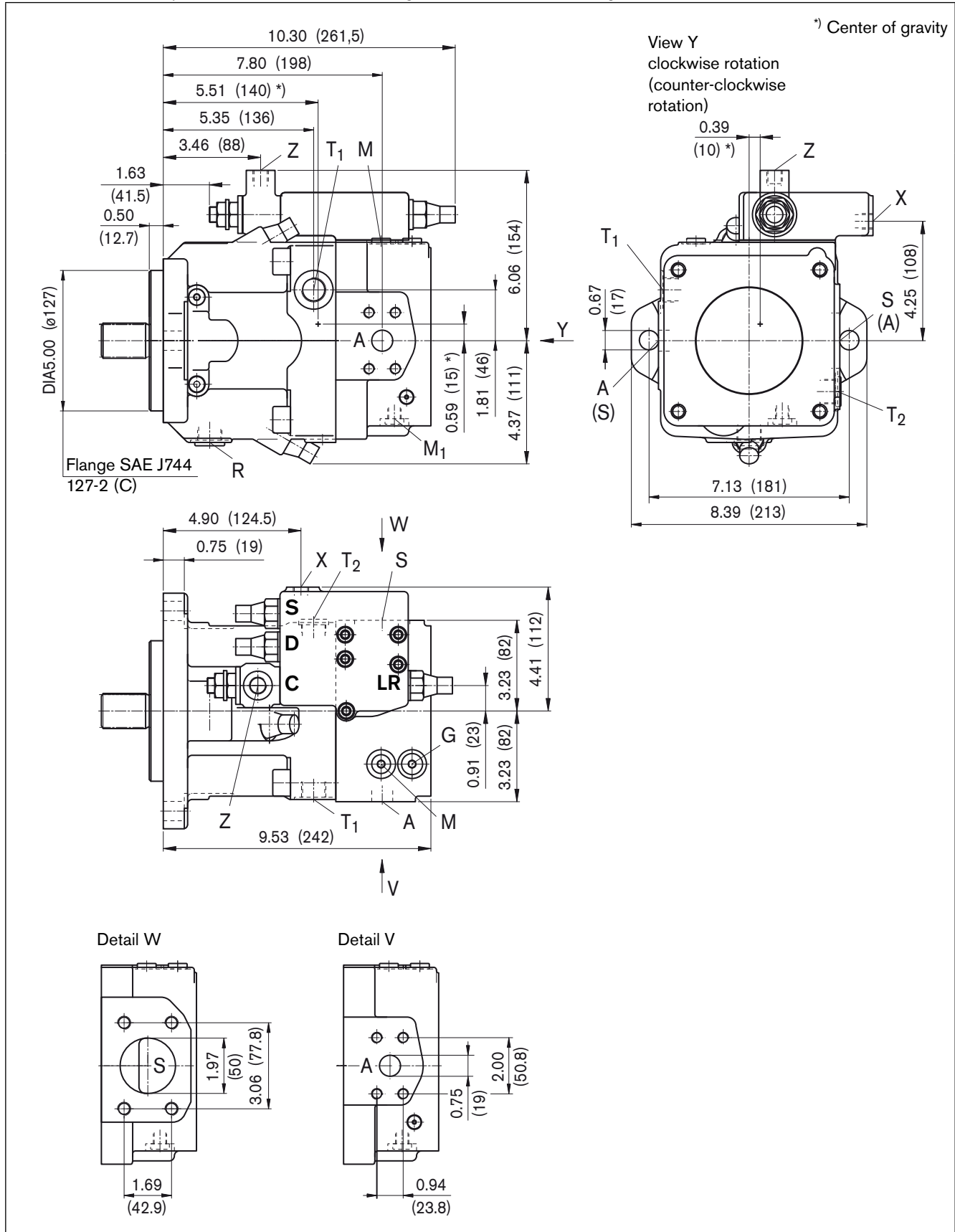

Dimensions size 60

Before finalizing your design, please request a certified drawing. Dimensions in inches and (millimeters).

Drive shaft

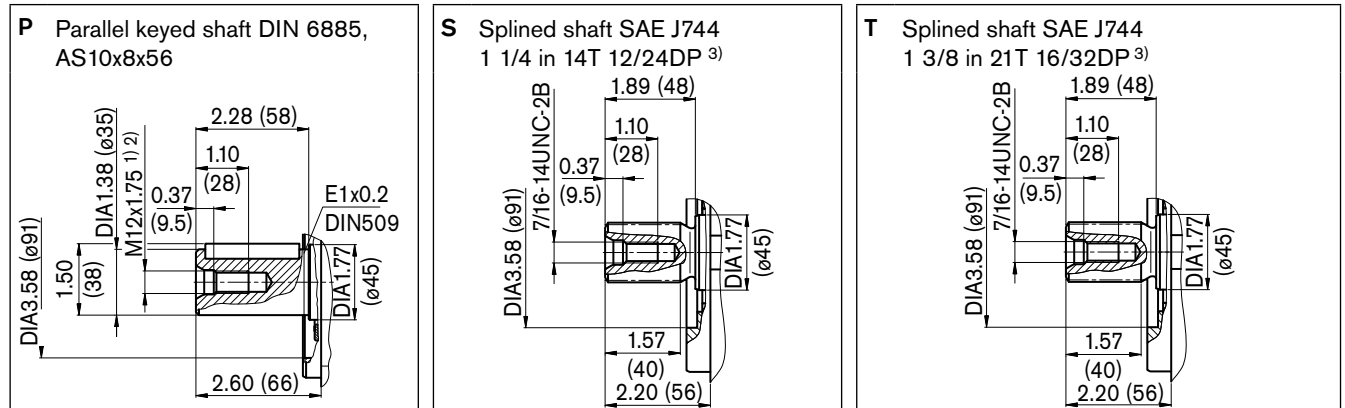

Ports

Designation	Function	Standard	Size ²⁾	Max. pressure [psi (bar)] ⁴⁾	State
A	Service line port	SAE J518	3/4 in	5800 (400)	O
	Fixing thread	ISO 68	3/8in-16UNC-2B; 0.67 (17) deep		
S	Suction port	SAE J518	2 in	435 (30)	O
	Fixing thread	ISO 68	1/2in-13UNC-2B; 0.79 (20) deep		
T ₁ , T ₂	Tank port	ISO 11926	7/8in-14UNF-2B; 0.55 (14) deep	145 (10)	5)
R	Air bleed	ISO 11926	7/8in-14UNF-2B; 0.55 (14) deep	145 (10)	X
M ₁	Measurement point, positioning chamber	ISO 11926	9/16in-18UNF-2B; 0.47 (12) deep	5800 (400)	X
M	Measurement point, service line port	ISO 11926	9/16in-18UNF-2B; 0.47 (12) deep	5800 (400)	X
X	Pilot pressure port in version with load sensing (S) and remote controlled pressure cut-off (G)	ISO 11926	9/16in-18UNF-2B; 0.47 (12) deep	5800 (400)	O
Y	Pilot pressure port in version with stroke limiter (H...), 2-stage pressure cut-off (E) and HD	ISO 11926	9/16in-18UNF-2B; 0.47 (12) deep	580 (40)	O
Z	Pilot pressure port in version with cross sensing (C) and power override (LR3) power override (LG1)	ISO 11926	9/16in-18UNF-2B; 0.47 (12) deep	5800 (400) 580 (40)	O
G	Port for control pressure (controller) in version with stroke limiter (H..., U2), HD and EP with screw union GE10 - PLM (otherwise closed)	ISO 11926	9/16in-18UNF-2B; 0.47 (12) deep	580 (40)	O

1) Center bore according to DIN 332 (thread acc. to DIN 13)

2) For maximum tightening torque, please refer to general notes on page 64

3) ANSI B92.1a-1976, 30° pressure angle, flat root, side fit, tolerance class 5

4) Depending on adjustment data and operating pressure

5) Depending on installation position, T₁ or T₂ must be connected (see also page 61)

O= Open, must be connected (closed on delivery)

X= Closed (in normal operation)

Dimensions size 60

Before finalizing your design,
please request a certified drawing.
Dimensions in inches and (millimeters).

LRDH1/LRDH5

Power control with pressure cut-off and hydraulic stroke limiter
(negative characteristic)

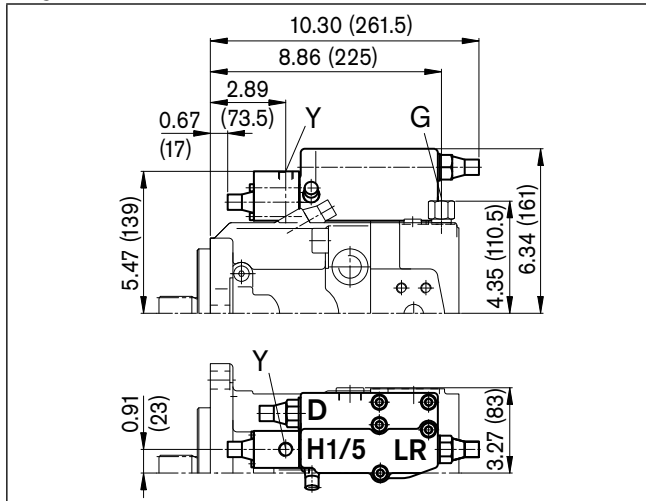

LRDH2/LRDH6

Power control with pressure cut-off and hydraulic stroke limiter
(positive characteristic)

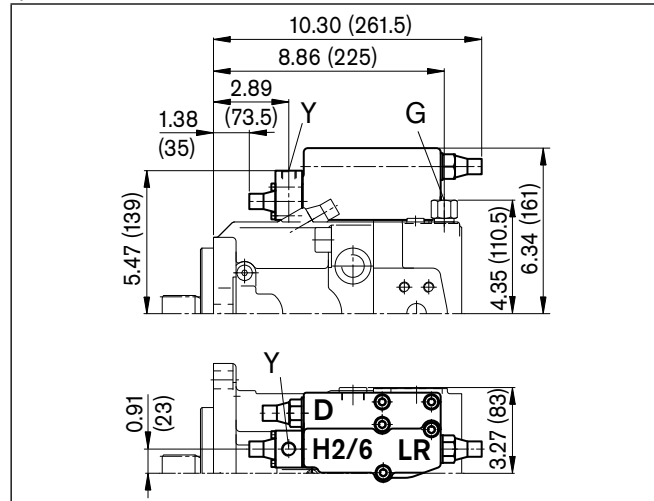

LRDU1/LRDU2

Power control with pressure cut-off and electric stroke limiter
(positive characteristic)

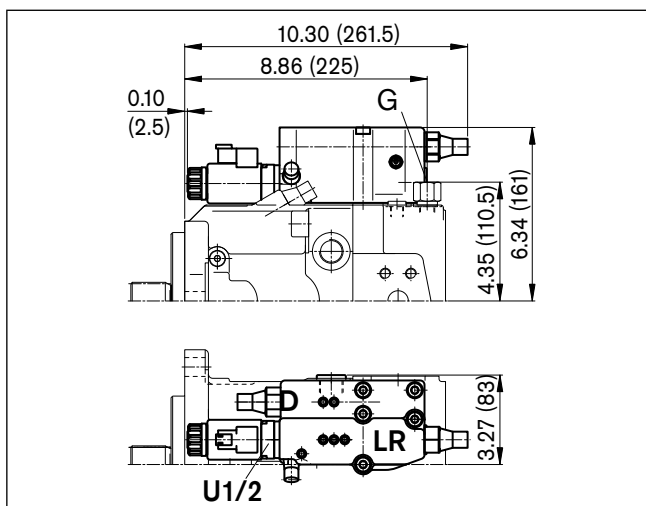

LR3DS

Power control with high-pressure related override,
pressure cut-off and load sensing control

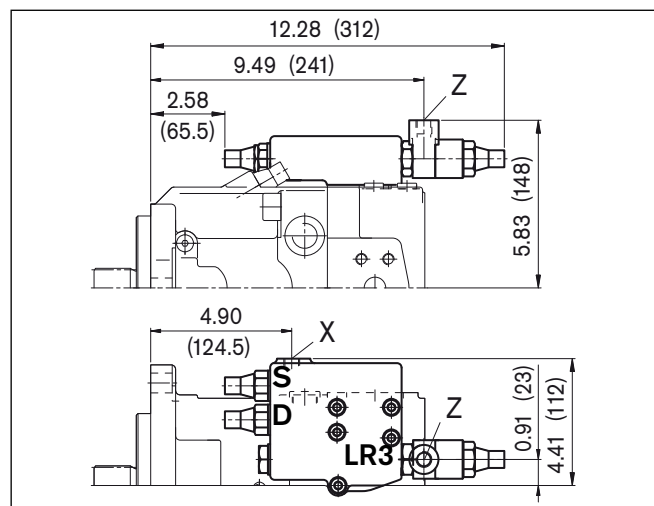

LG1E

Power control with pilot-pressure related override
(negative) and 2-stage pressure cut-off

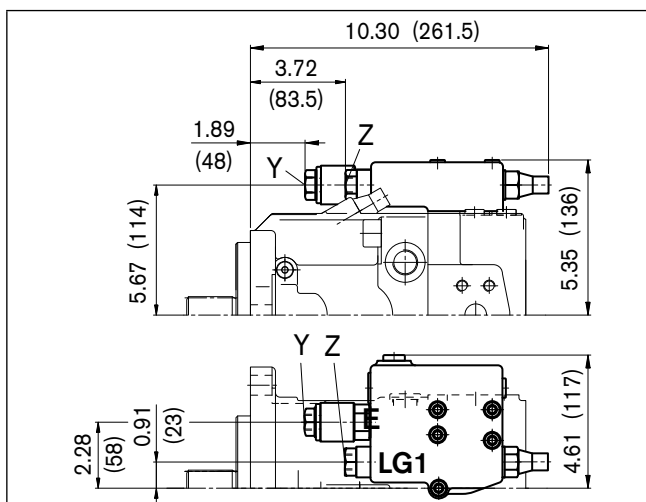

LG2E

Power control with pilot-pressure related override
(positive) and 2-stage pressure cut-off

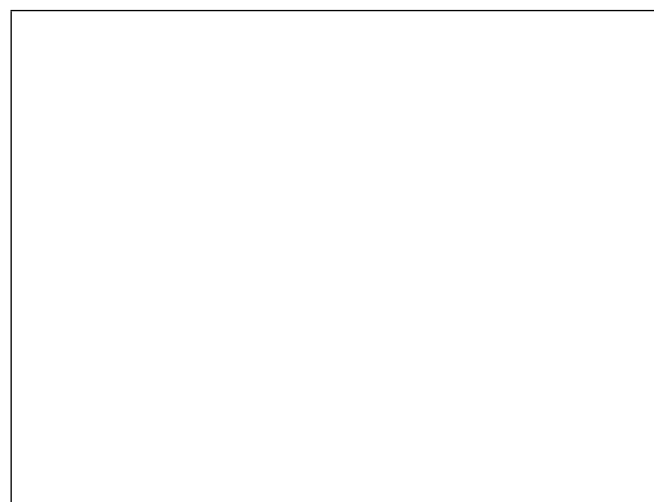

Dimensions size 60

Before finalizing your design,
please request a certified drawing.
Dimensions in inches and (millimeters).

HD1D/HD2D

Hydraulic control, pilot-pressure related with pressure cut-off

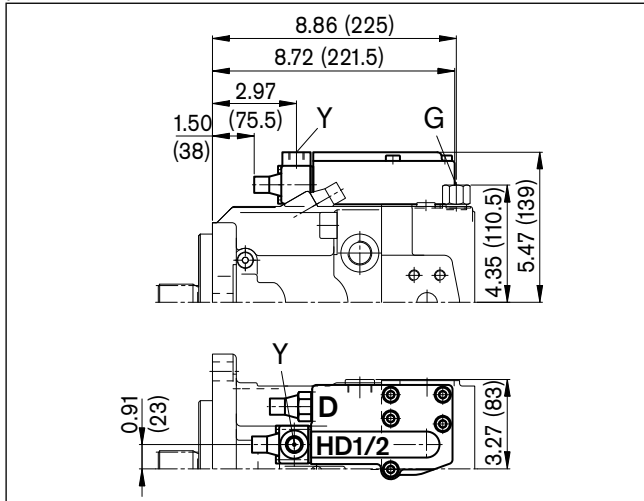

EP1D/EP2D

Electric control with proportional solenoid and pressure cut-off

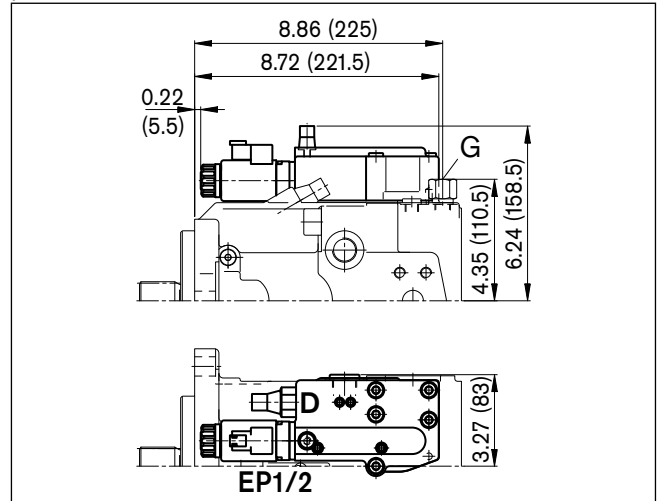

DRS/DRG

Pressure control with load sensing control
Pressure control remote controlled

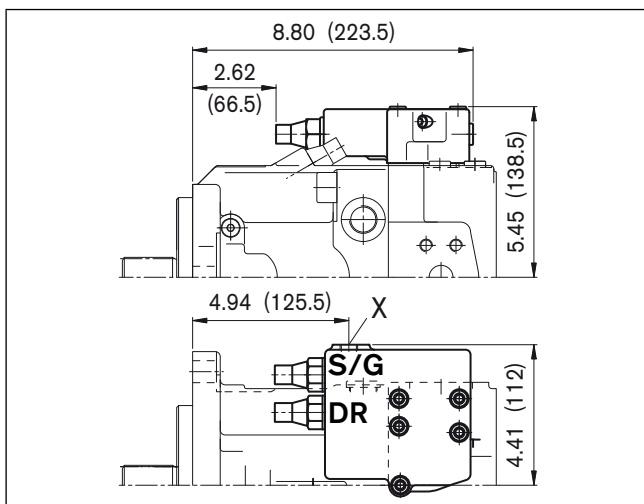

DRL

Pressure control for parallel operation

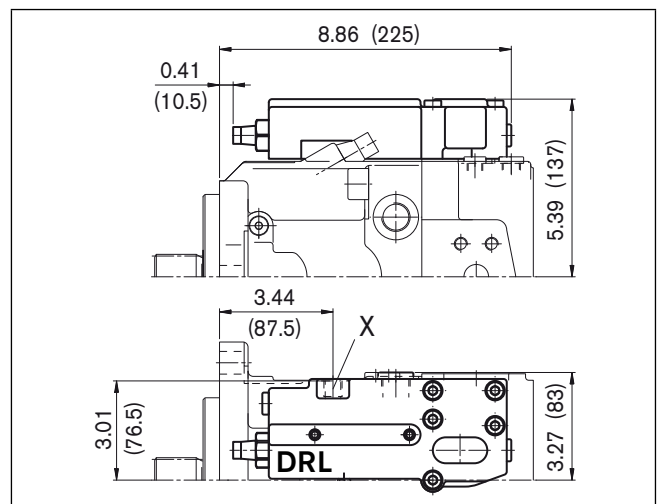

LE1S/LE2S

Power control with electric override (negative)
and load sensing control

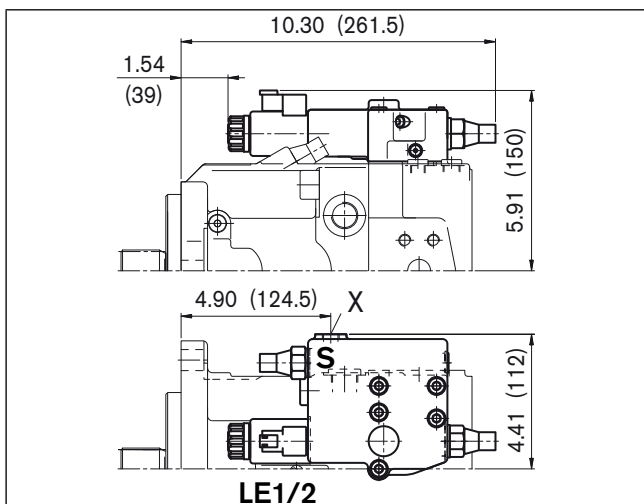

LE2S2/LE1S5/LE2S5

Power control with electric override (negative)
and load sensing control, override

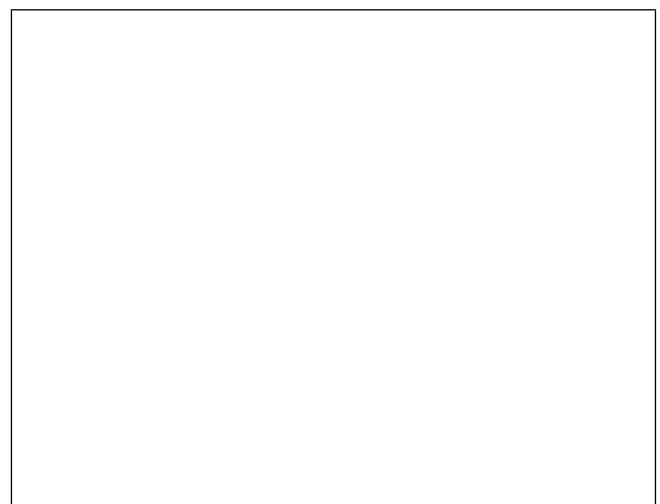

Dimensions size 75

Before finalizing your design,
please request a certified drawing.
Dimensions in inches and (millimeters).

LRDCS

Power control LR with pressure cut-off D, cross sensing control C and load sensing control S

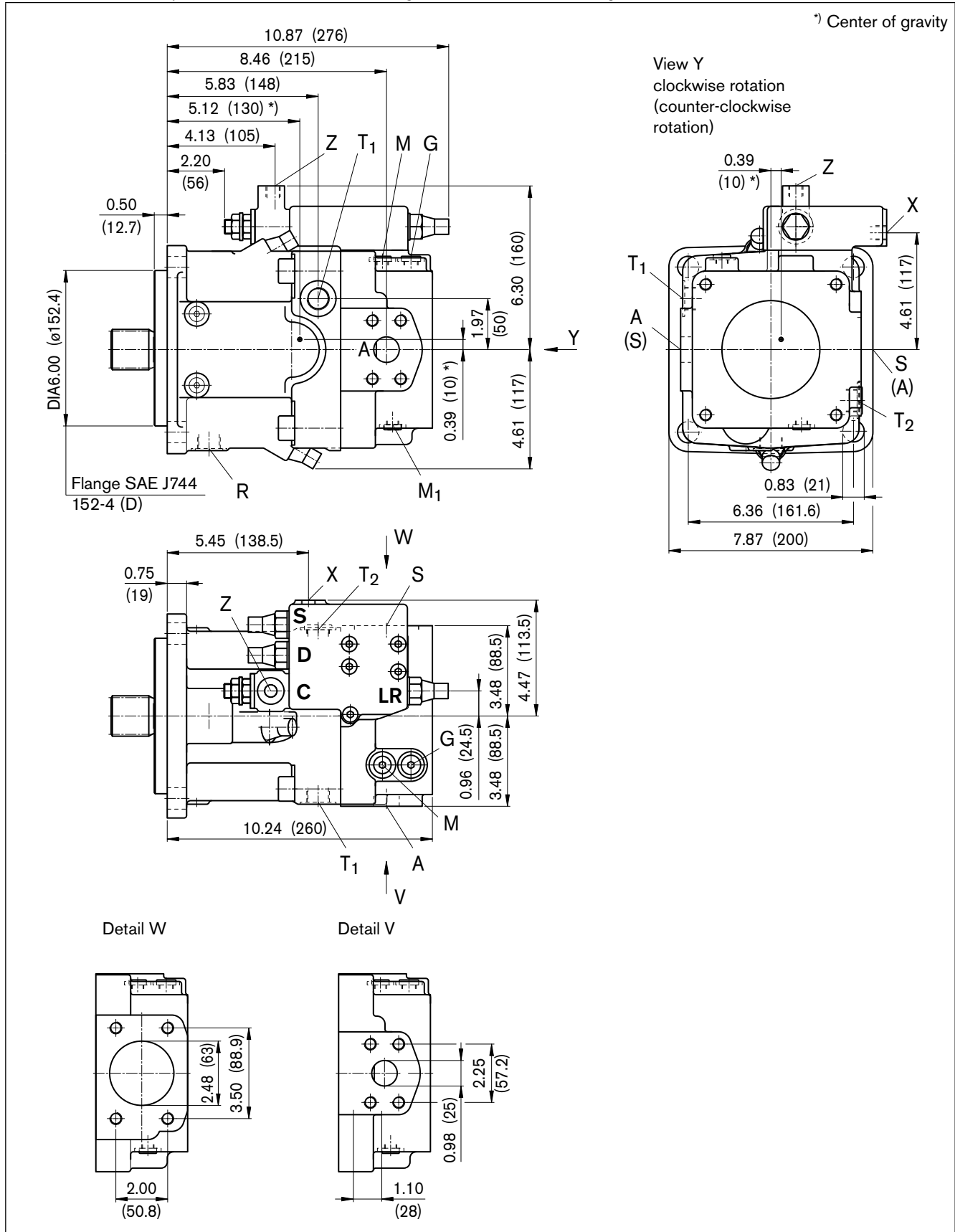

Dimensions size 75

Before finalizing your design, please request a certified drawing. Dimensions in inches and (millimeters).

Drive shaft

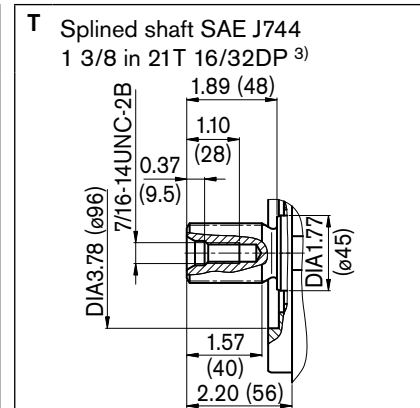
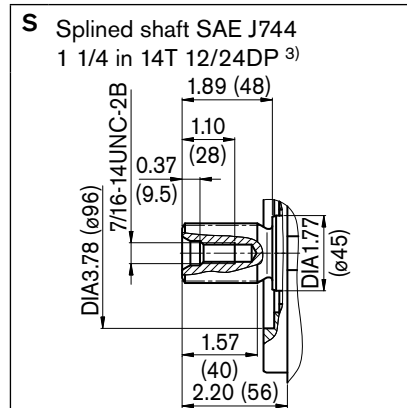
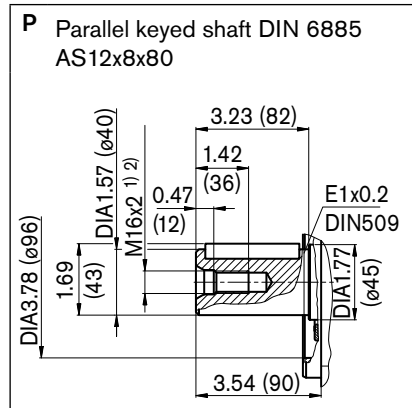

Ports

Designation	Function	Standard	Size ²⁾	Max. pressure [psi (bar)] ⁴⁾	State
A	Service line port	SAE J518	1 in	5800 (400)	O
	Fixing thread	ISO 68	7/16in-14UNC-2B; 0.67 (17) deep		
S	Suction port	SAE J518	2 1/2in	435 (30)	O
	Fixing thread	ISO 68	1/2in-13UNC-2B; 0.67 (17) deep		
T ₁ , T ₂	Tank port	ISO 11926	7/8in-14UNF-2B; 0.55 (14) deep	145 (10)	⁵⁾
R	Air bleed	ISO 11926	7/8in-14UNF-2B; 0.55 (14) deep	145 (10)	X
M ₁	Measurement point, positioning chamber	ISO 11926	9/16in-18UNF-2B; 0.47 (12) deep	5800 (400)	X
M	Measurement point, service line port	ISO 11926	9/16in-18UNF-2B; 0.47 (12) deep	5800 (400)	X
X	Pilot pressure port in version with load sensing (S) and remote controlled pressure cut-off (G)	ISO 11926	9/16in-18UNF-2B; 0.47 (12) deep	5800 (400)	O
Y	Pilot pressure port in version with stroke limiter (H...), 2-stage pressure cut-off (E) and HD	ISO 11926	9/16in-18UNF-2B; 0.47 (12) deep	580 (40)	O
Z	Pilot pressure port in version with cross sensing (C) and power override (LR3) power override (LG1)	ISO 11926	9/16in-18UNF-2B; 0.47 (12) deep	5800 (400) 580 (40)	O
G	Port for control pressure (controller) in version with stroke limiter (H..., U2), HD and EP with screw union GE10 - PLM (otherwise closed)	ISO 11926	9/16in-18UNF-2B; 0.47 (12) deep	580 (40)	O

1) Center bore according to DIN 332 (thread acc. to DIN 13)

2) For maximum tightening torque, please refer to general notes on page 64

3) ANSI B92.1a-1976, 30° pressure angle, flat root, side fit, tolerance class 5

4) Depending on adjustment data and operating pressure

5) Depending on installation position, T₁ or T₂ must be connected (see also page 61)

O = Open, must be connected (closed on delivery)

X = Closed (in normal operation)

Dimensions size 75

Before finalizing your design,
please request a certified drawing.
Dimensions in inches and (millimeters).

LRDH1/LRDH5

Power control with pressure cut-off and hydraulic stroke limiter (negative characteristic)

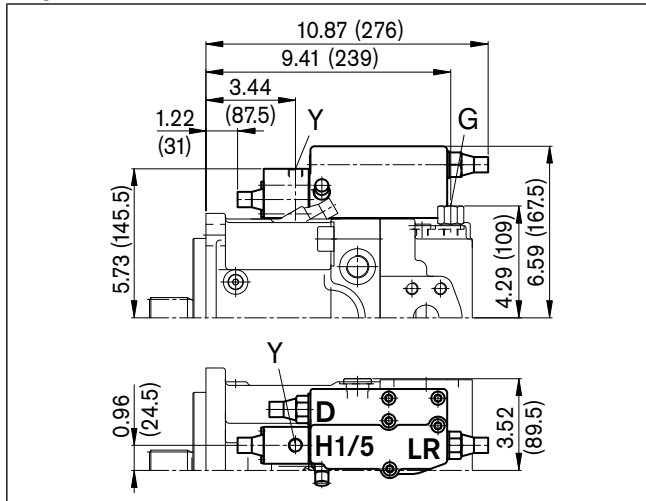

LRDH2/LRDH6

Power control with pressure cut-off and hydraulic stroke limiter (positive characteristic)

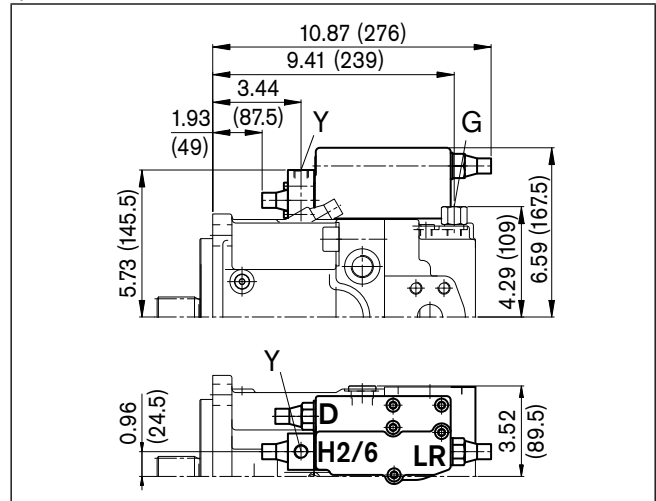

LRDU1/LRDU2

Power control with pressure cut-off and electric stroke limiter (positive characteristic)

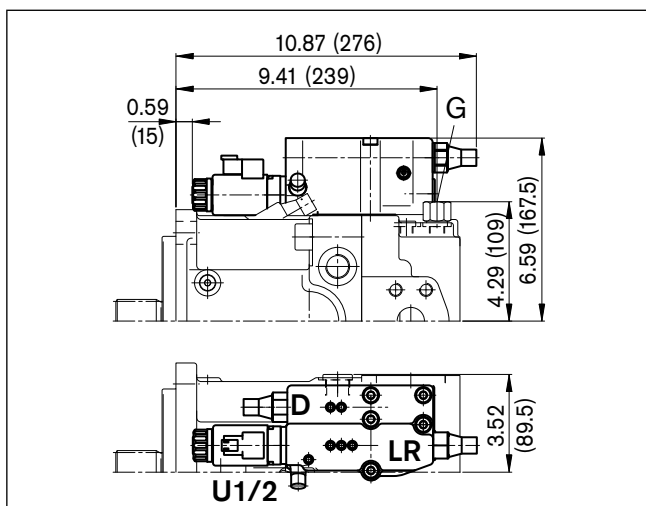

LR3DS

Power control with high-pressure related override, pressure cut-off and load sensing control

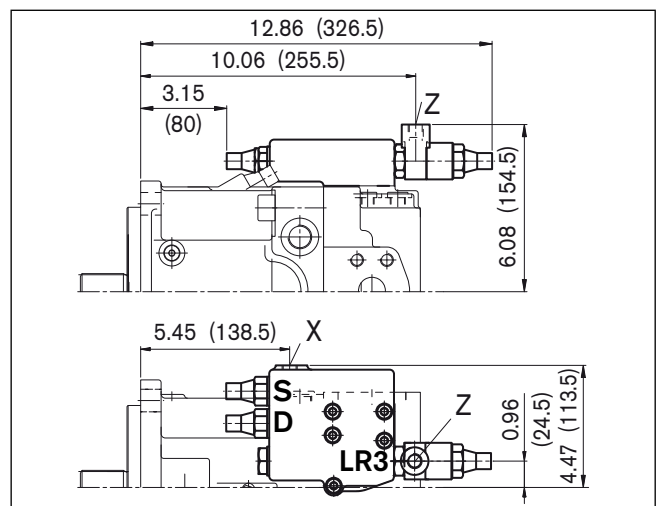

LG1E

Power control with pilot-pressure related override (negative) and 2-stage pressure cut-off

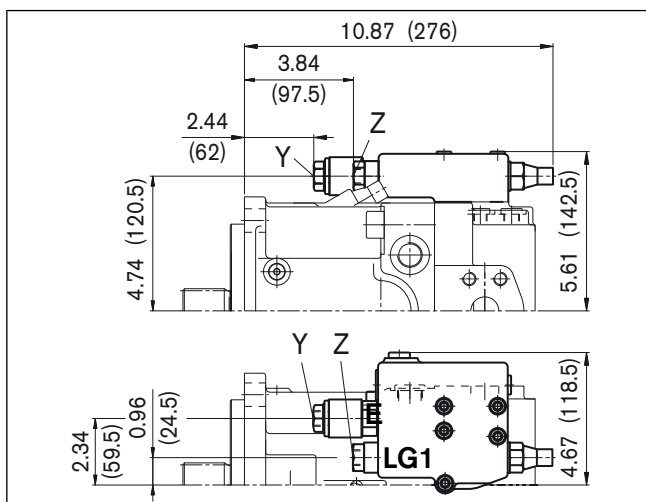

LG2E

Power control with pilot-pressure related override (positive) and 2-stage pressure cut-off

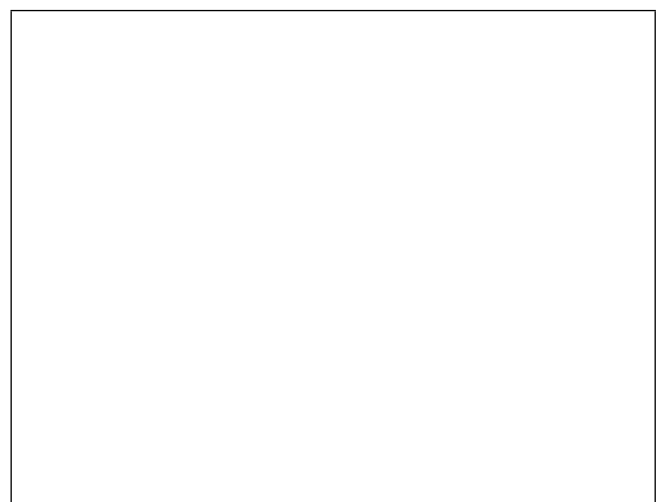

Dimensions size 75

Before finalizing your design,
please request a certified drawing.
Dimensions in inches and (millimeters).

HD1D/HD2D

Hydraulic control, pilot-pressure related with pressure cut-off

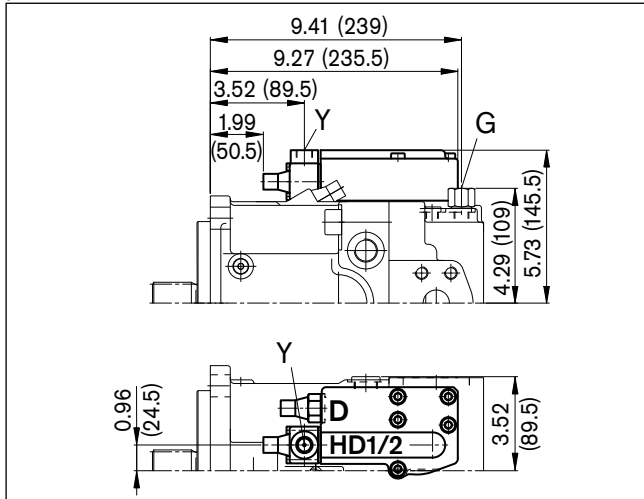

EP1D/EP2D

Electric control with proportional solenoid and pressure cut-off

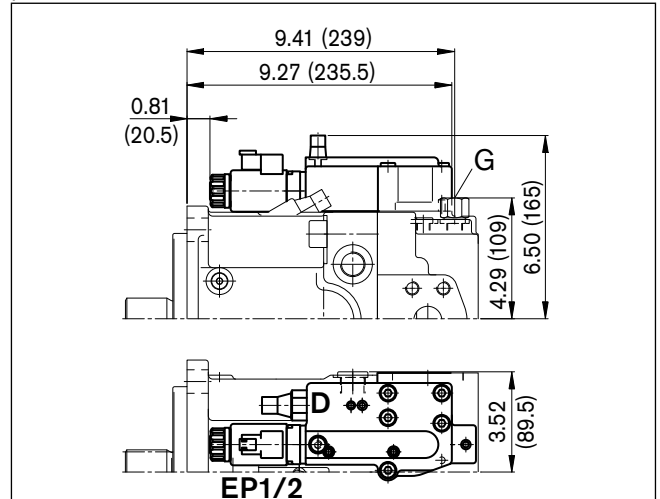

DRS/DRG

Pressure control with load sensing control
Pressure control remote controlled

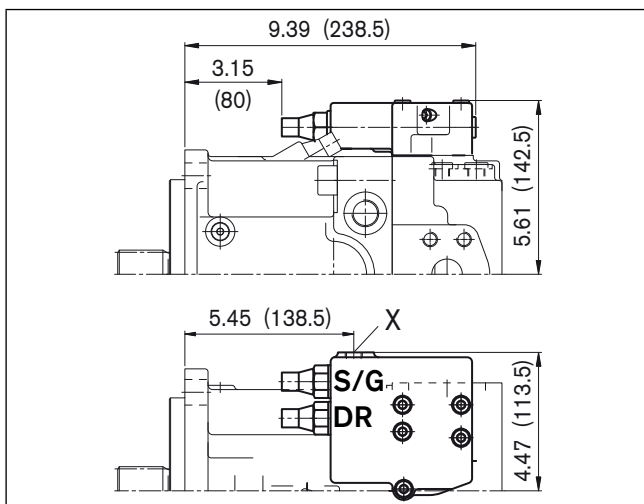

DRL

Pressure control for parallel operation

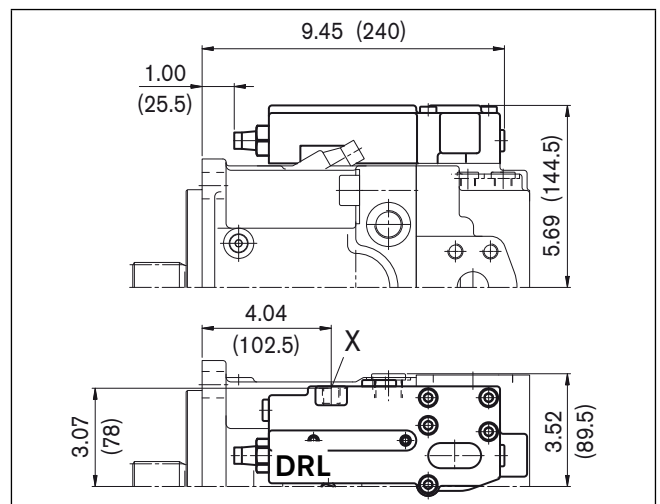

LE1S/LE2S

Power control with electric override (negative)
and load sensing control

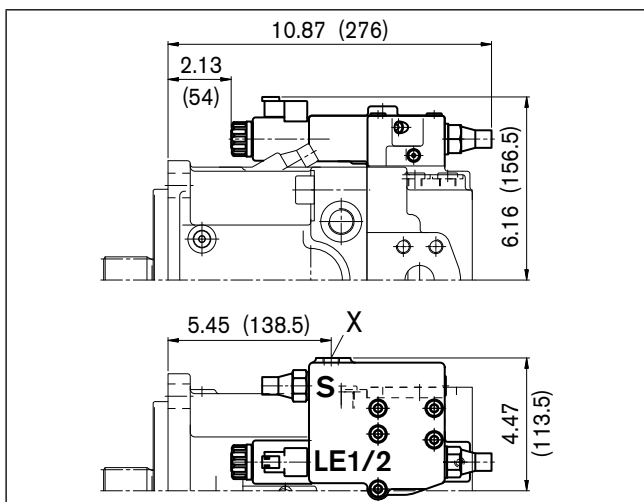

LE2S2/LE1S5/LE2S5

Power control with electric override (negative)
and load sensing control, override

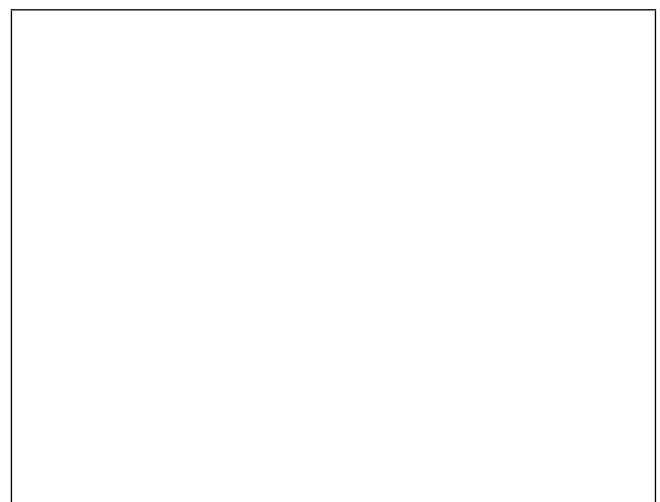

Dimensions size 95

Before finalizing your design,
please request a certified drawing.
Dimensions in inches and (millimeters).

LRDCS

Power control LR with pressure cut-off D, cross sensing control C and load sensing control S

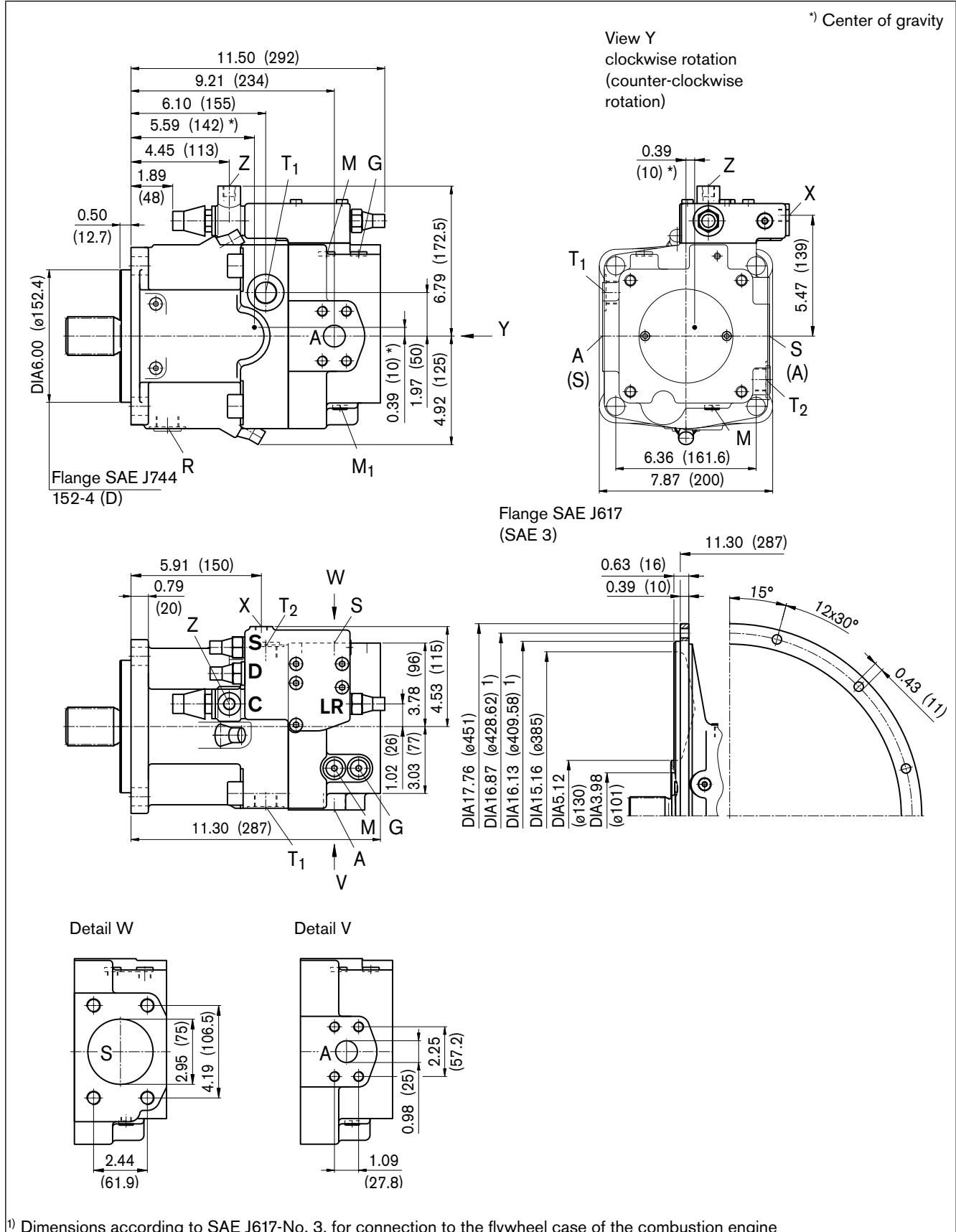

Dimensions size 95

Before finalizing your design,
please request a certified drawing.
Dimensions in inches and (millimeters).

Drive shaft

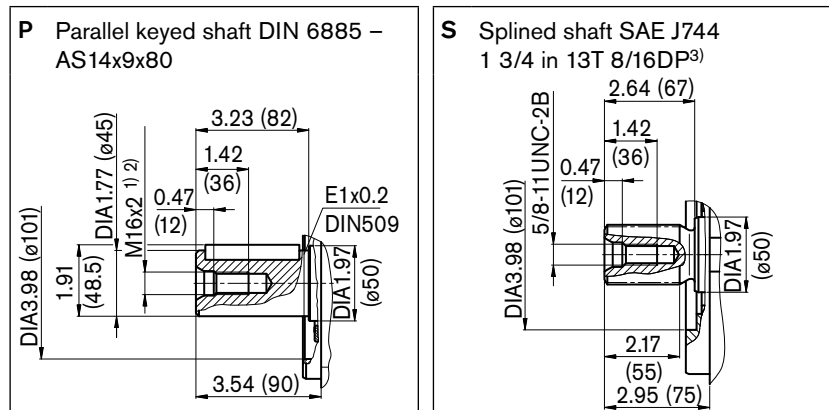

Ports

Designation	Function	Standard	Size ²⁾	Max. pressure [psi (bar)] ⁴⁾	State
A	Service line port	SAE J518	1 in	5800 (400)	O
	Fixing thread	ISO 68	7/16in-14UNC-2B; 0.67 (17) deep		
S	Suction port	SAE J518	3 in	435 (30)	O
	Fixing thread	ISO 68	5/8in-11UNC-2B; 0.94 (24) deep		
T ₁ , T ₂	Tank port	ISO 11926	1 1/16in-12UNF-2B; 0.63 (16) deep	145 (10)	⁵⁾
R	Air bleed	ISO 11926	1 1/16in-12UNF-2B; 0.63 (16) deep	145 (10)	X
M ₁	Measurement point, positioning chamber	ISO 11926	9/16in-18UNF-2B; 0.47 (12) deep	580 (400)	X
M	Measurement point, service line port	ISO 11926	9/16in-18UNF-2B; 0.47 (12) deep	5800 (400)	X
X	Pilot pressure port in version with load sensing (S) and remote controlled pressure cut-off (G)	ISO 11926	9/16in-18UNF-2B; 0.47 (12) deep	5800 (400)	O
Y	Pilot pressure port in version with stroke limiter (H...), 2-stage pressure cut-off (E) and HD	ISO 11926	9/16in-18UNF-2B; 0.47 (12) deep	580 (40)	O
Z	Pilot pressure port in version with cross sensing (C) and power override (LR3) power override (LG1)	ISO 11926	9/16in-18UNF-2B; 0.47 (12) deep	5800 (400) 580 (40)	O
G	Port for control pressure (controller) in version with stroke limiter (H..., U2), HD and EP with screw union GE10 - PLM (otherwise closed)	ISO 11926	9/16in-18UNF-2B; 0.47 (12) deep	580 (40)	O

1) Center bore according to DIN 332 (thread acc. to DIN 13)

2) For maximum tightening torque, please refer to general notes on page 64

3) ANSI B92.1 a-1976, 30° pressure angle, flat root, side fit, tolerance class 5

4) Depending on adjustment data and operating pressure

5) Depending on installation position, T₁ or T₂ must be connected (see also page 61)

O = Open, must be connected (closed on delivery)

X = Closed (in normal operation)

Dimensions size 95

Before finalizing your design,
please request a certified drawing.
Dimensions in inches and (millimeters).

LRDH1/LRDH5

Power control with pressure cut-off and hydraulic stroke limiter (negative characteristic)

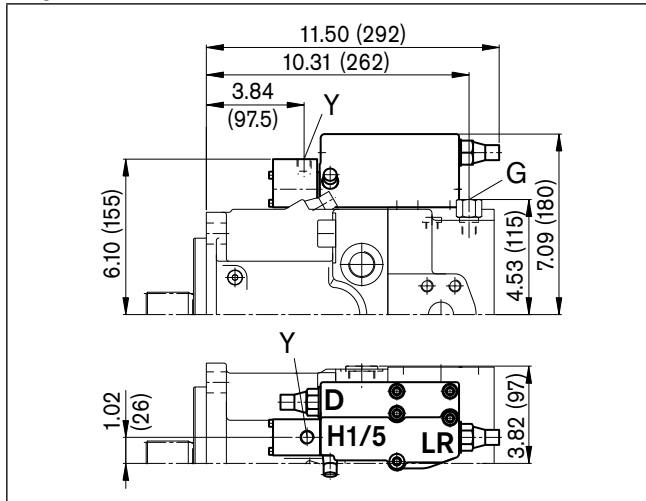

LRDH2/LRDH6

Power control with pressure cut-off and hydraulic stroke limiter (positive characteristic)

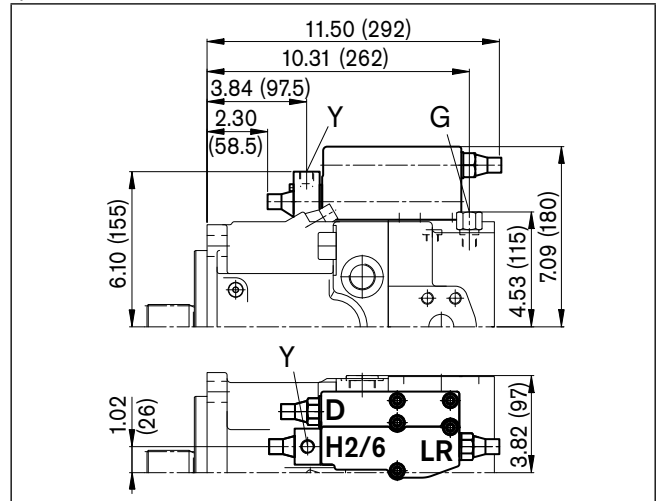

LRDU1/LRDU2

Power control with pressure cut-off and electric stroke limiter (positive characteristic)

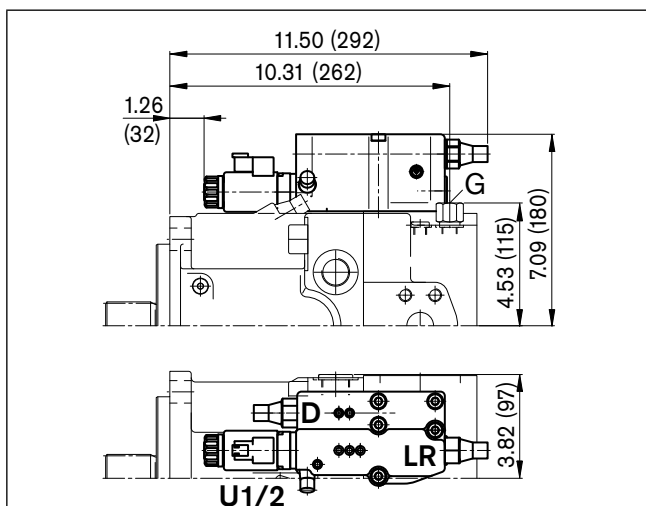

LR3DS

Power control with high-pressure related override, pressure cut-off and load sensing control

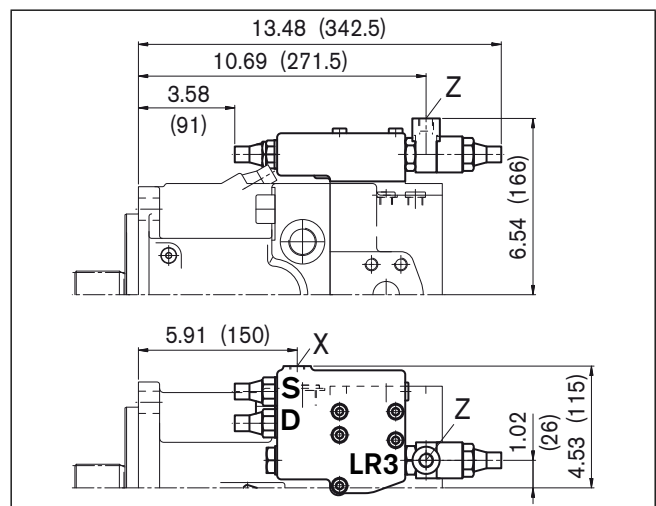

LG1E

Power control with pilot-pressure related override (negative) and 2-stage pressure cut-off

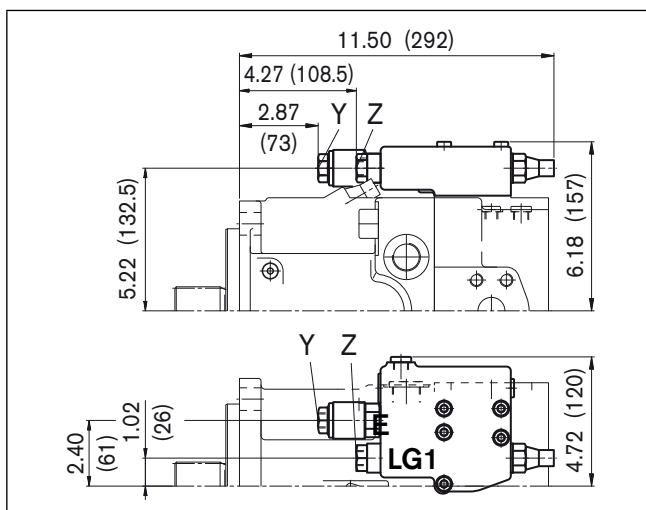

LG2E

Power control with pilot-pressure related override (positive) and 2-stage pressure cut-off

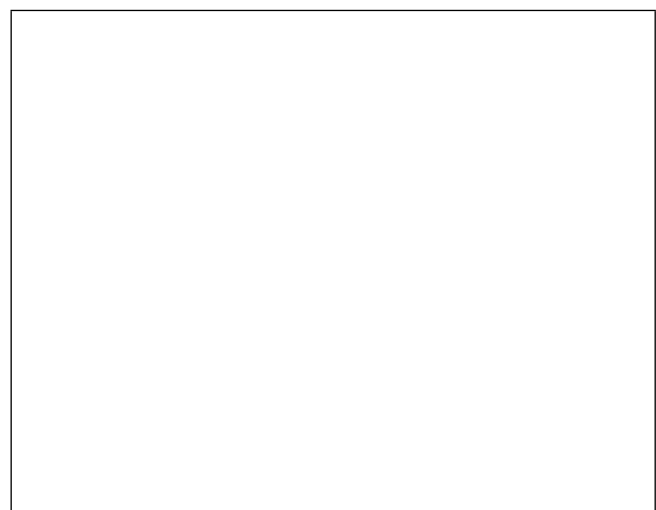

Dimensions size 95

Before finalizing your design,
please request a certified drawing.
Dimensions in inches and (millimeters).

HD1D/HD2D

Hydraulic control, pilot-pressure related with pressure cut-off

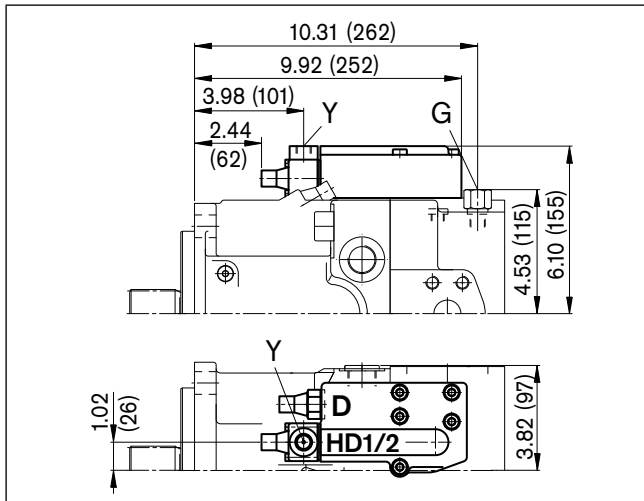

EP1D/EP2D

Electric control with proportional solenoid and pressure cut-off

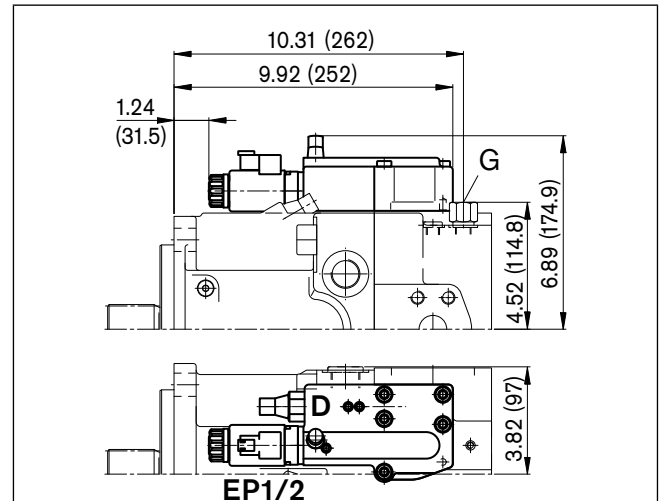

DRS/DRG

Pressure control with load sensing control
Pressure control remote controlled

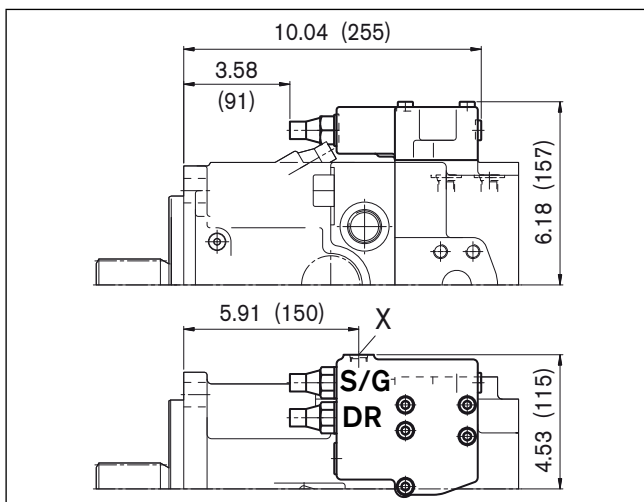

DRL

Pressure control for parallel operation

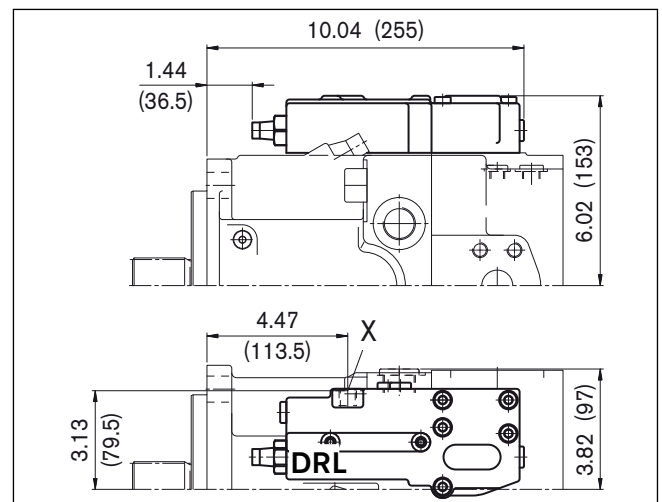

LE1S/LE2S

Power control with electric override (negative)
and load sensing control

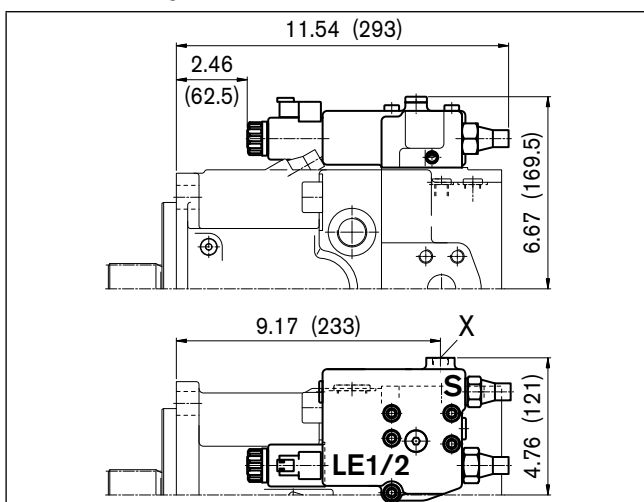

LE2S2/LE1S5/LE2S5

Power control with electric override (negative)
and load sensing control, override

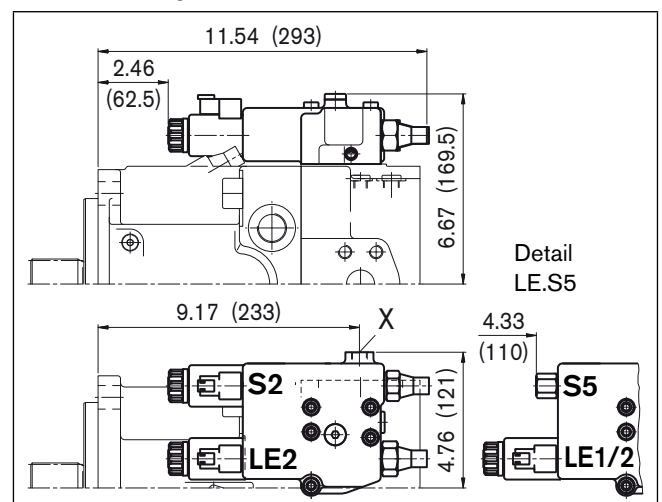

Dimensions size 130/145

Before finalizing your design,
please request a certified drawing.
Dimensions in inches and (millimeters).

LRDCS

Power control LR with pressure cut-off D, cross sensing control C and load sensing control S

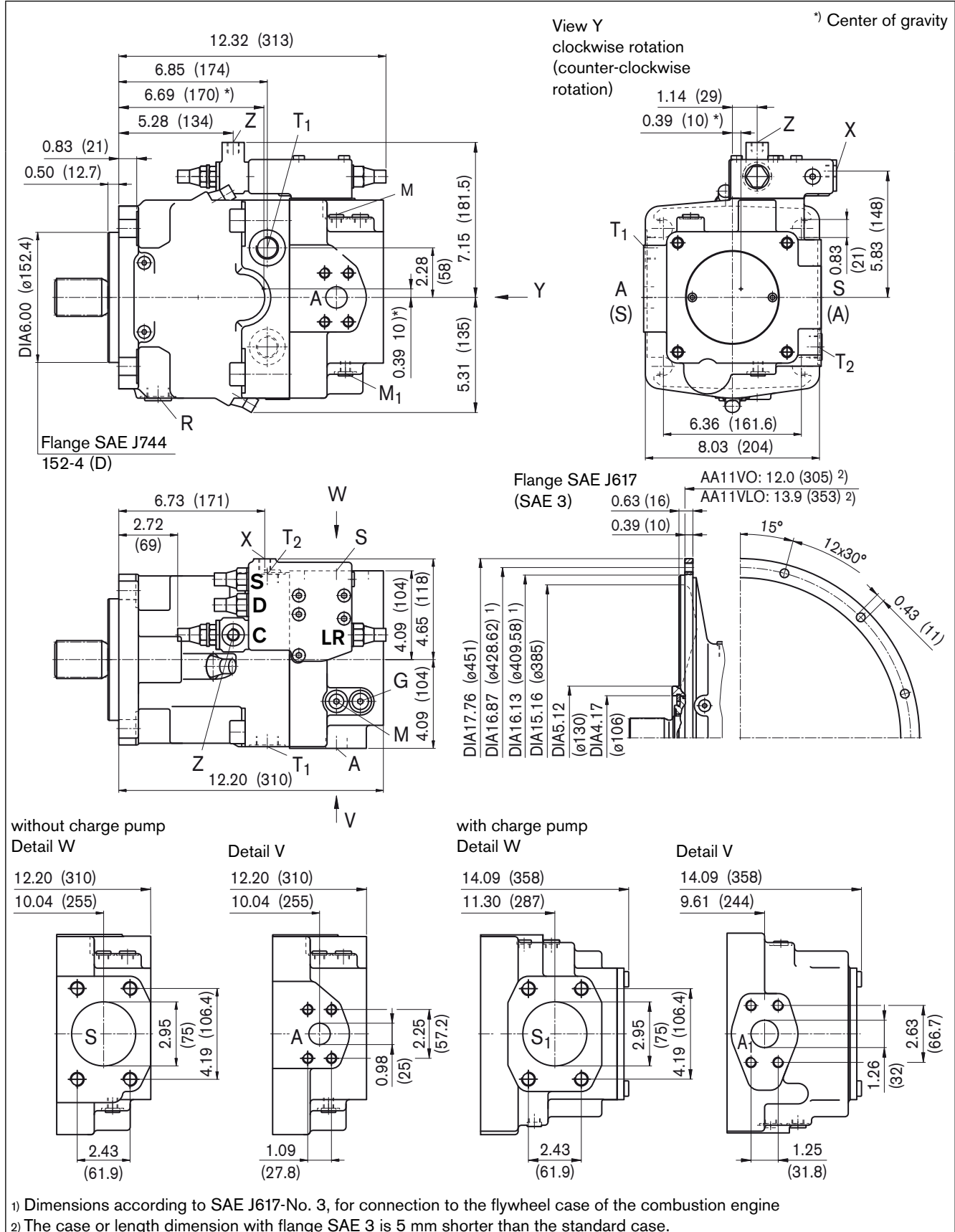

Dimensions size 130/145

Before finalizing your design, please request a certified drawing. Dimensions in inches and (millimeters).

Drive shaft

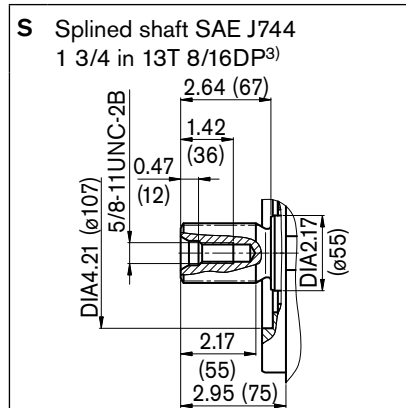
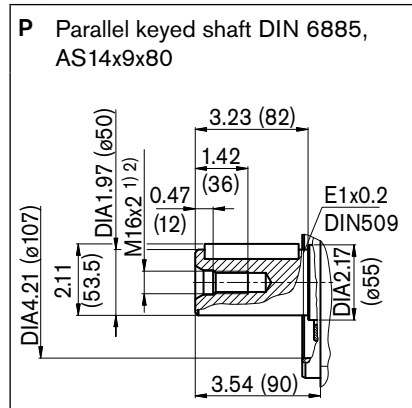

Ports

Designation	Function	Standard	Size ²⁾	Max. pressure [psi (bar)] ⁴⁾	State	
A	Service line port Fixing thread	SAE J518 ISO 68	1 in 7/16in-14UNC-2B;	0.67 (17) deep	5800 (400)	O
A ₁	Service line port Fixing thread	SAE J518 ISO 68	1 1/4 in 1/2in-13UNC-2B;	0.75 (19) deep	5800 (400)	O
S, S ₁	Suction port Fixing thread	SAE J518 ISO 68	3 in 5/8in-11UNC-2B;	0.94 (24) deep	435 (30) 30 (2) ⁶⁾	O
T ₁ , T ₂	Tank port	ISO 11926	1 1/16in-12UNF-2B;	0.63 (16) deep	145 (10)	⁵⁾
R	Air bleed	ISO 11926	1 1/16in-12UNF-2B;	0.63 (16) deep	145 (10)	X
M ₁	Measurement point, positioning chamber	ISO 11926	9/16in-18UNF-2B;	0.47 (12) deep	5800 (400)	X
M	Measurement point, service line port	ISO 11926	9/16in-18UNF-2B;	0.47 (12) deep	5800 (400)	X
X	Pilot pressure port in version with load sensing (S) and remote controlled pressure cut-off (G)	ISO 11926	9/16in-18UNF-2B;	0.47 (12) deep	5800 (400)	O
Y	Pilot pressure port in version with stroke limiter (H...), 2-stage pressure cut-off (E) and HD	ISO 11926	9/16in-18UNF-2B;	0.47 (12) deep	580 (40)	O
Z	Pilot pressure port in version with cross sensing (C) and power override (LR3) power override (LG1)	ISO 11926	9/16in-18UNF-2B;	0.47 (12) deep	5800 (400) 580 (40)	O
G	Port for control pressure (controller) in version with stroke limiter (H., U2), HD and EP with screw union GE10 - PLM (otherwise closed)	ISO 11926	9/16in-18UNF-2B;	0.47 (12) deep	580 (40)	O

- 1) Center bore according to DIN 332 (thread acc. to DIN 13)
- 2) For maximum tightening torque, please refer to general notes on page 64
- 3) ANSI B92.1 a-1976, 30° pressure angle, flat root, side fit, tolerance class 5
- 4) Depending on adjustment data and operating pressure
- 5) Depending on installation position, T₁ or T₂ must be connected (see also page 61)
- 6) with charge pump

O = Open, must be connected (closed on delivery)
X = Closed (in normal operation)

Dimensions size 130/145

Before finalizing your design,
please request a certified drawing.
Dimensions in inches and (millimeters).

LRDH1/LRDH5

Power control with pressure cut-off and hydraulic stroke limiter (negative characteristic)

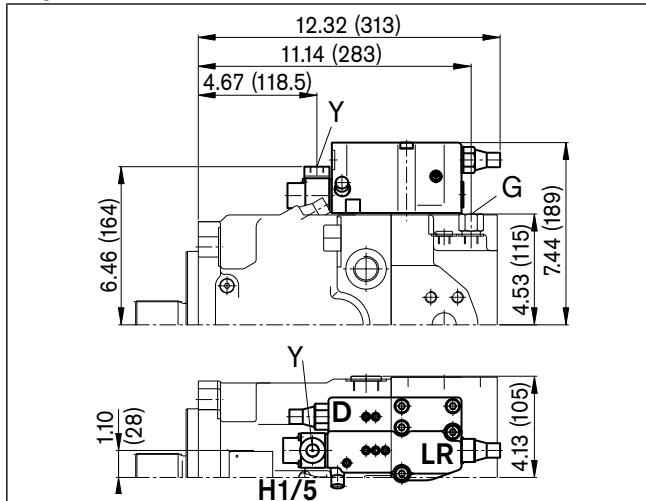

LRDH2/LRDH6

Power control with pressure cut-off and hydraulic stroke limiter (positive characteristic)

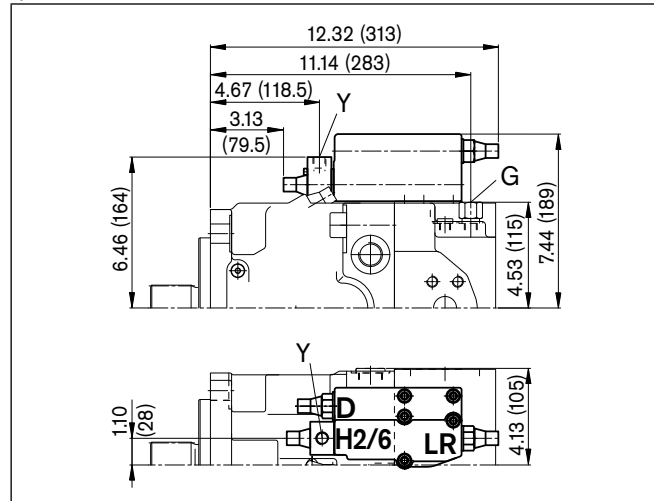

LRDU1/LRDU2

Power control with pressure cut-off and electric stroke limiter (positive characteristic)

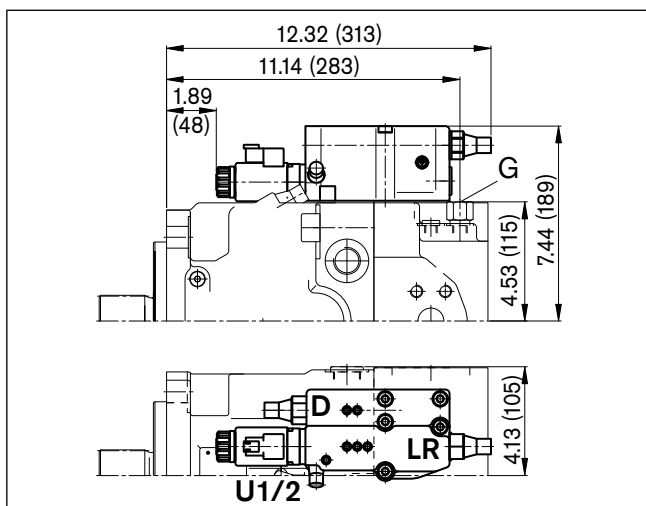

LR3DS

Power control with high-pressure related override, pressure cut-off and load sensing control

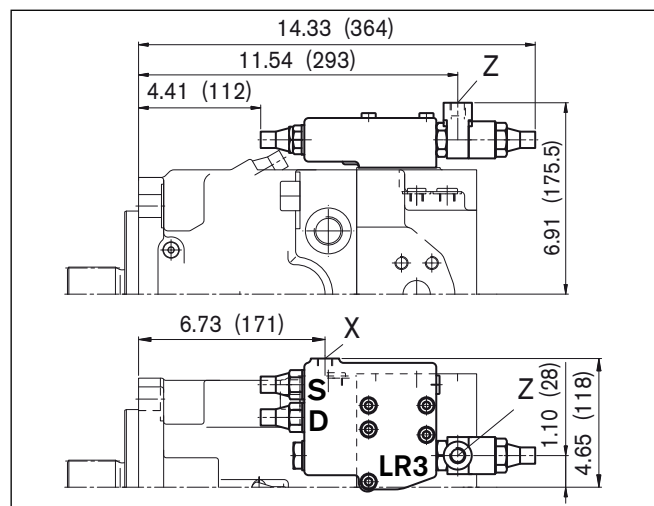

LG1E

Power control with pilot-pressure related override (negative) and 2-stage pressure cut-off

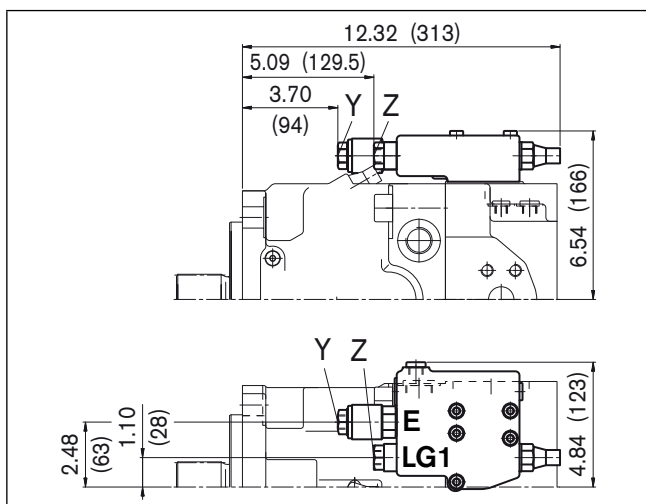

LG2E

Power control with pilot-pressure related override (positive) and 2-stage pressure cut-off

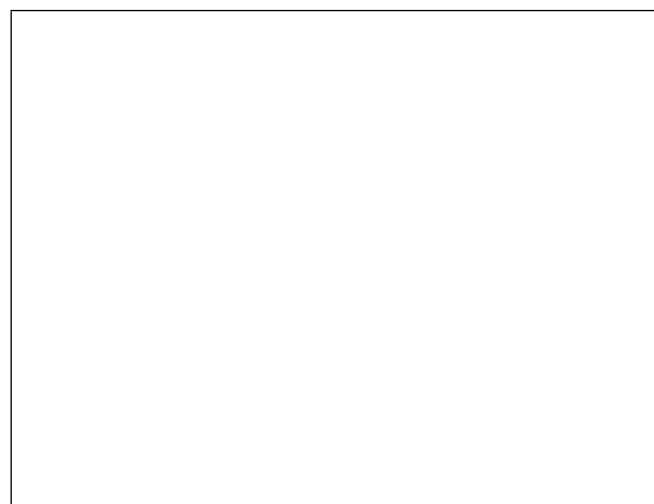

Dimensions size 130/145

Before finalizing your design,
please request a certified drawing.
Dimensions in inches and (millimeters).

HD1D/HD2D

Hydraulic control, pilot-pressure related with pressure cut-off

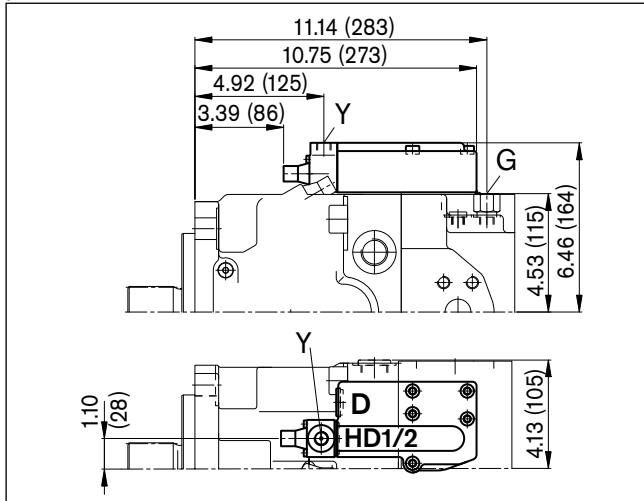

EP1D/EP2D

Electric control with proportional solenoid and pressure cut-off

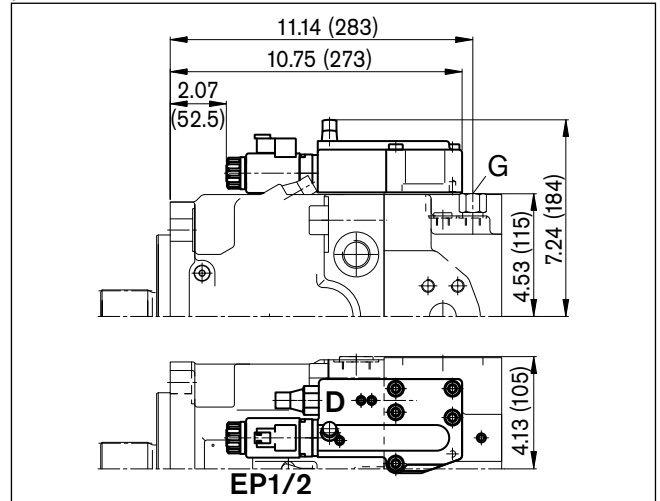

DRS/DRG

Pressure control with load sensing control
Pressure control remote controlled

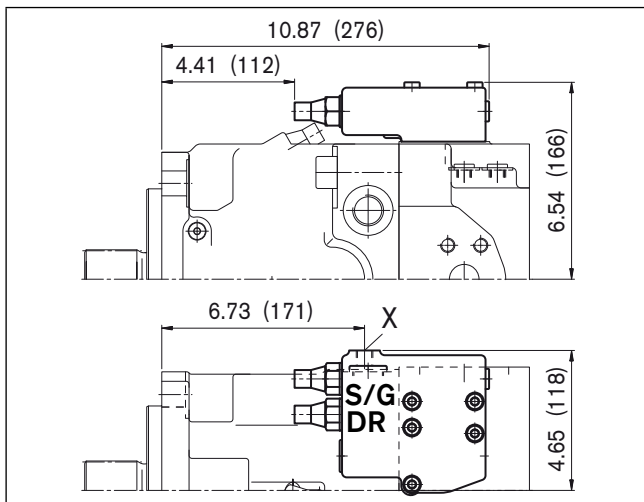

DRL

Pressure control for parallel operation

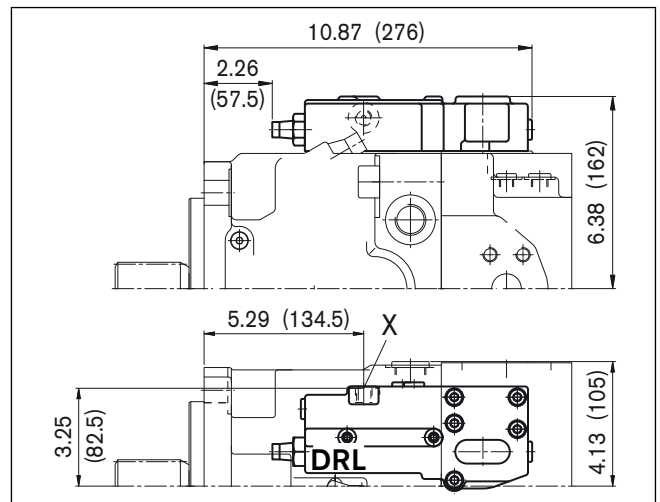

LE1S/LE2S

Power control with electric override (negative)
and load sensing control

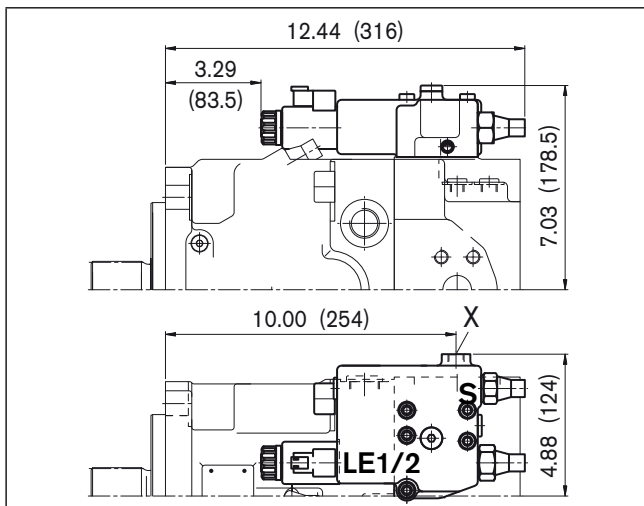

LE2S2/LE1S5/LE2S5

Power control with electric override (negative)
and load sensing control, override

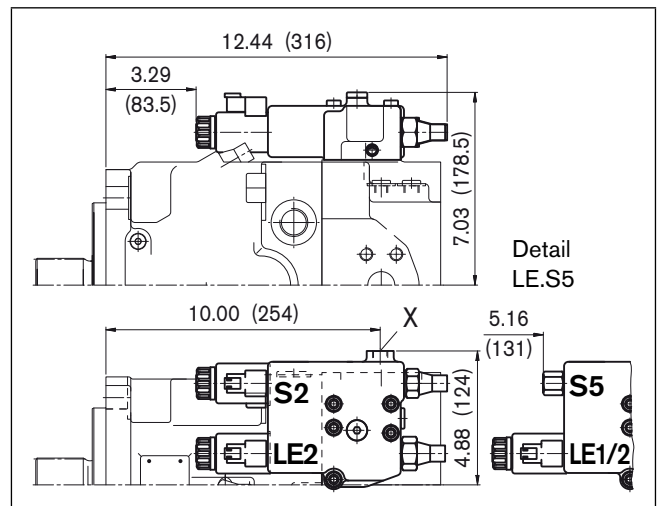

Dimensions size 190

Before finalizing your design,
please request a certified drawing.
Dimensions in inches and (millimeters).

LRDCS

Power control LR with pressure cut-off D, cross sensing control C and load sensing control S

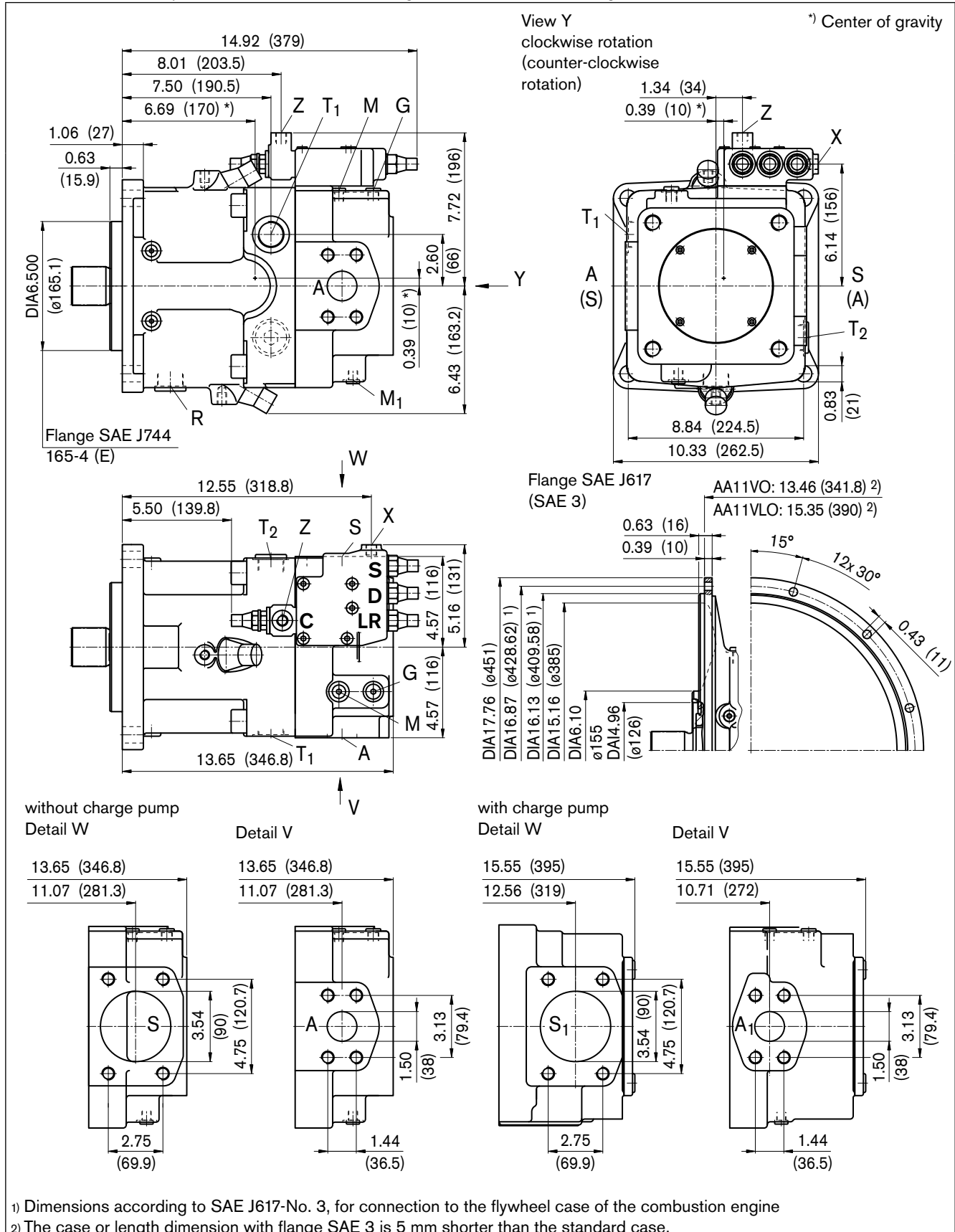

Dimensions size 190

Before finalizing your design, please request a certified drawing. Dimensions in inches and (millimeters).

Drive shaft

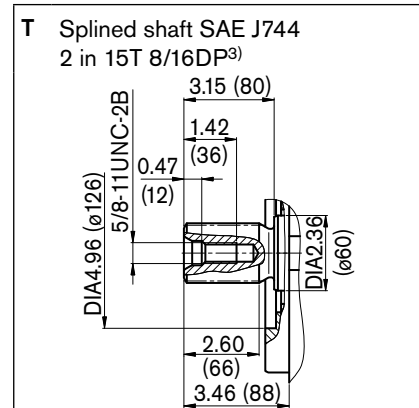
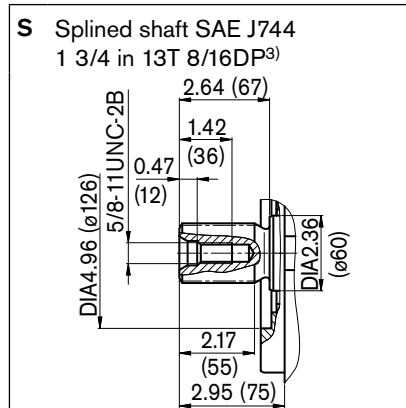
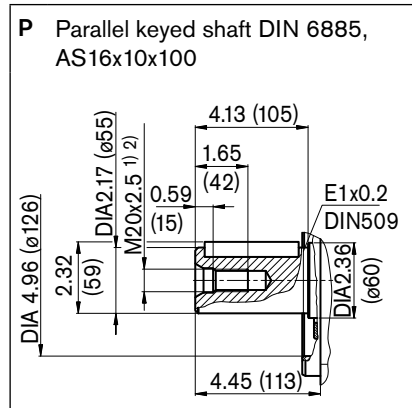

Ports

Designation	Function	Standard	Size ²⁾	Max. pressure [psi (bar)] ⁴⁾	State
A, A ₁	Service line port Fixing thread	SAE J518 ISO 68	1 1/2 in 5/8in-11UNC-2B;	0.83 (21) deep 5800 (400)	O
S, S ₁	Suction port Fixing thread	SAE J518 ISO 68	3 1/2 in 5/8in-11UNC-2B;	0.94 (24) deep 435 (30) 30 (2) ⁶⁾	O
T ₁ , T ₂	Tank port	ISO 11926	1 5/16in-12UNF-2B;	0.71 (18) deep 145 (10)	⁵⁾
R	Air bleed	ISO 11926	1 5/16in-12UNF-2B;	0.71 (18) deep 145 (10)	X
M ₁	Measurement point, positioning chamber	ISO 11926	9/16in-18UNF-2B;	0.47 (12) deep 5800 (400)	X
M	Measurement point, service line port	ISO 11926	9/16in-18UNF-2B;	0.47 (12) deep 5800 (400)	X
X	Pilot pressure port in version with load sensing (S) and remote controlled pressure cut-off (G)	ISO 11926	9/16in-18UNF-2B;	0.47 (12) deep 5800 (400)	O
Y	Pilot pressure port in version with stroke limiter (H...), 2-stage pressure cut-off (E) and HD	ISO 11926	9/16in-18UNF-2B;	0.47 (12) deep 580 (40)	O
Z	Pilot pressure port in version with cross sensing (C) and power override (LR3) power override (LG1)	ISO 11926	9/16in-18UNF-2B;	0.47 (12) deep 5800 (400) 580 (40)	O
G	Port for control pressure (controller) in version with stroke limiter (H..., U2), HD and EP with screw union GE10 - PLM (otherwise closed)	ISO 11926	9/16in-18UNF-2B;	0.47 (12) deep 580 (40)	O

- 1) Center bore according to DIN 332 (thread acc. to DIN 13)
 - 2) For maximum tightening torque, please refer to general notes on page 64
 - 3) ANSI B92.1 a-1976, 30° pressure angle, flat root, side fit, tolerance class 5
 - 4) Depending on adjustment data and operating pressure
 - 5) Depending on installation position, T₁ or T₂ must be connected (see also page 61)
 - 6) with charge pump
- O = Open, must be connected (closed on delivery)
X = Closed (in normal operation)

Dimensions size 190

Before finalizing your design, please request a certified drawing. Dimensions in inches and (millimeters).

LRDH1/LRDH5

Power control with pressure cut-off and hydraulic stroke limiter (negative characteristic)

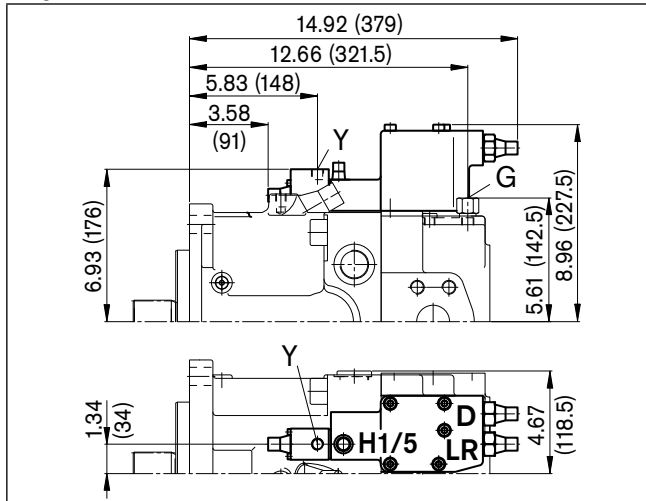

LRDH2/LRDH6

Power control with pressure cut-off and hydraulic stroke limiter (positive characteristic)

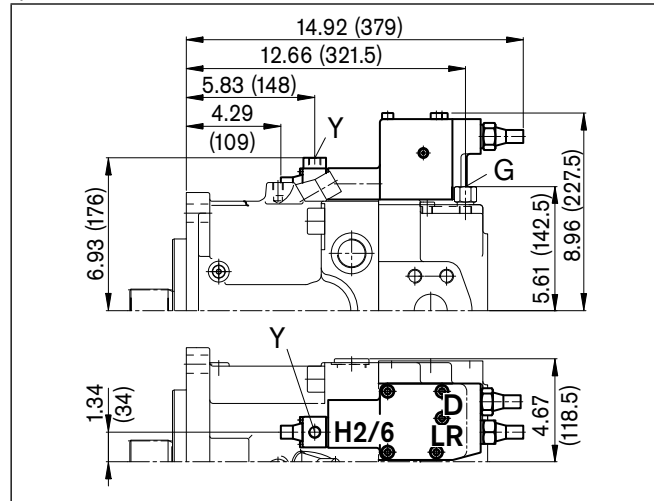

LRDU1/LRDU2

Power control with pressure cut-off and electric stroke limiter (positive characteristic)

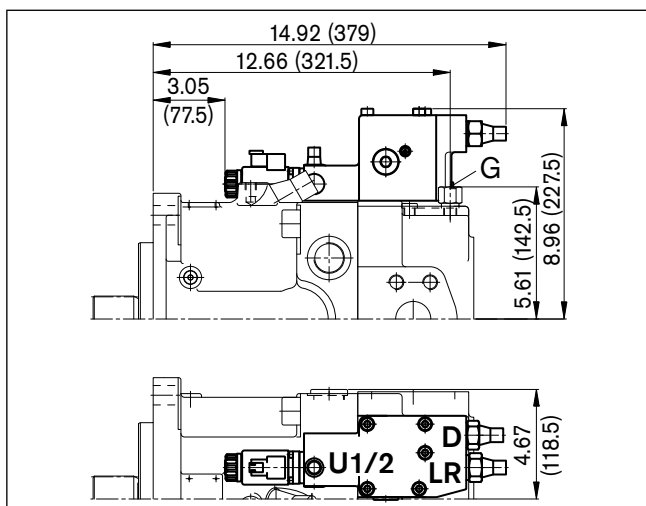

LR3DS

Power control with high-pressure related override, pressure cut-off and load sensing control

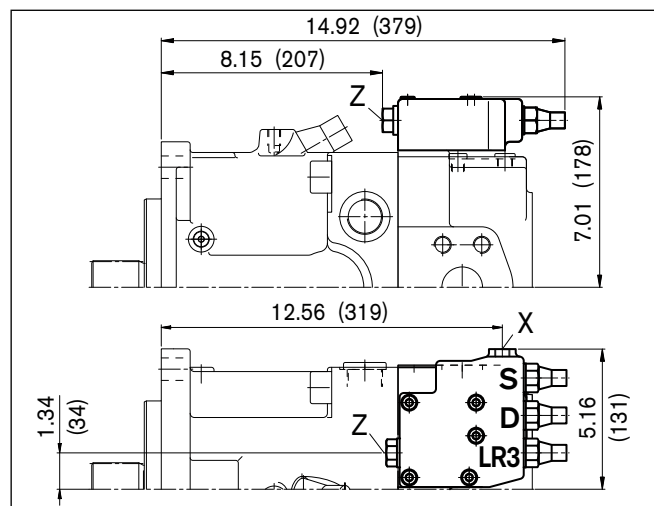

LG1EH

Power control with pilot-pressure related override (neg.), 2-stage pressure cut-off and hydr. stroke limiter

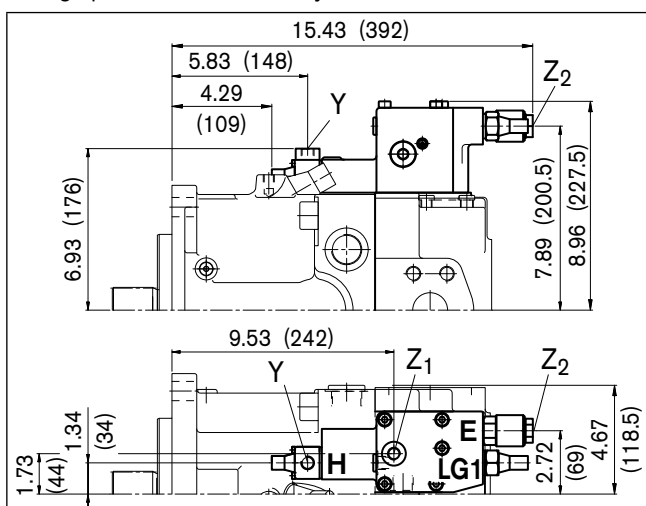

LG2EH

Power control with pilot-pressure related override (pos.), 2-stage pressure cut-off and hydr. stroke limiter

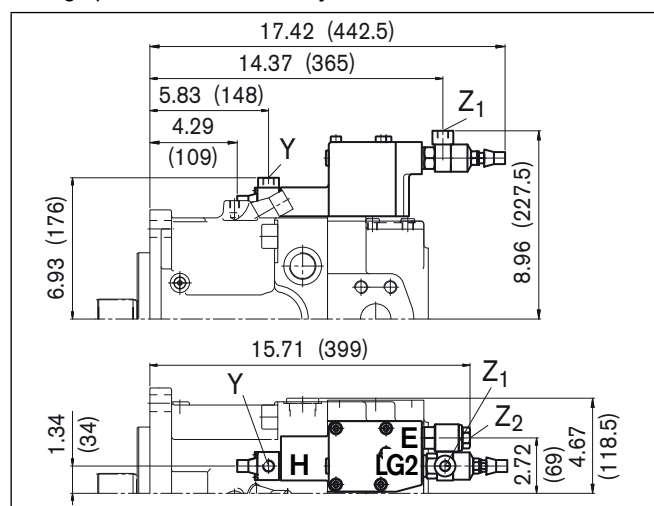

Dimensions size 190

Before finalizing your design,
please request a certified drawing.
Dimensions in inches and (millimeters).

HD1D/HD2D

Hydraulic control, pilot-pressure related with pressure cut-off

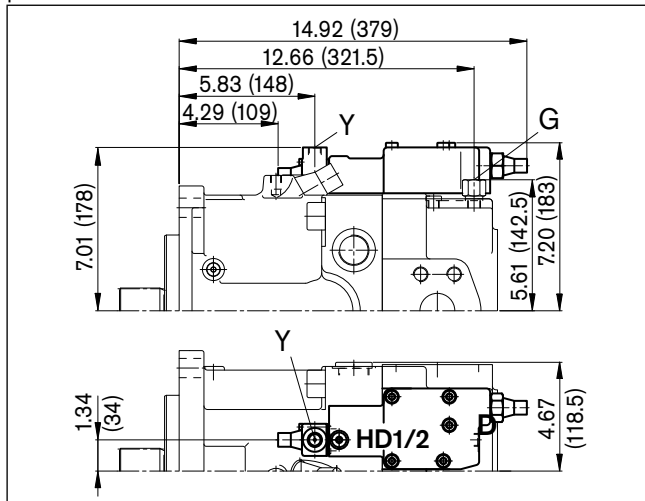

EP1D/EP2D

Electric control with proportional solenoid and pressure cut-off

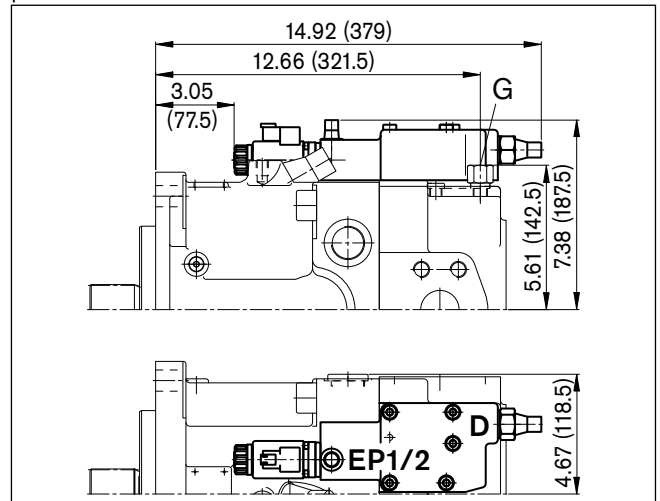

DRS/DRG

Pressure control with load sensing control
Pressure control remote controlled

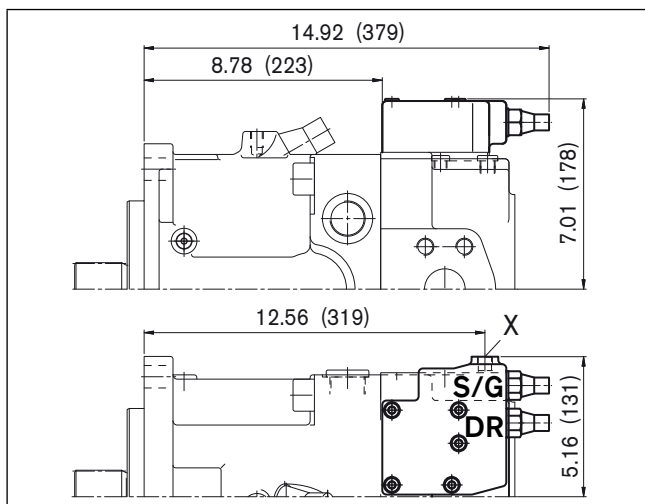

DRL

Pressure control for parallel operation

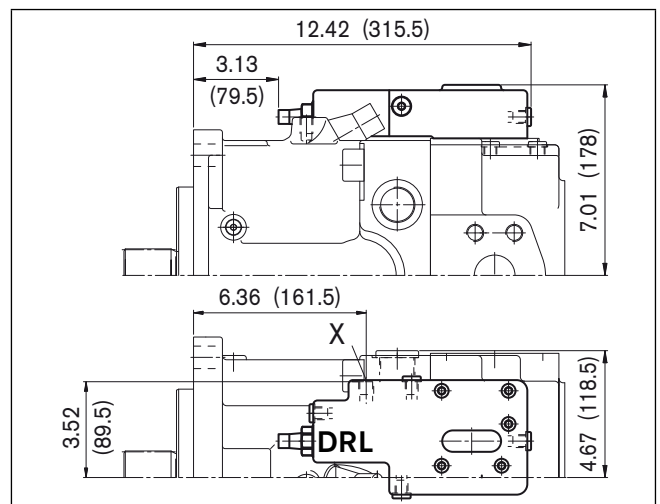

LE1S/LE2S

Power control with electric override (negative)
and load sensing control

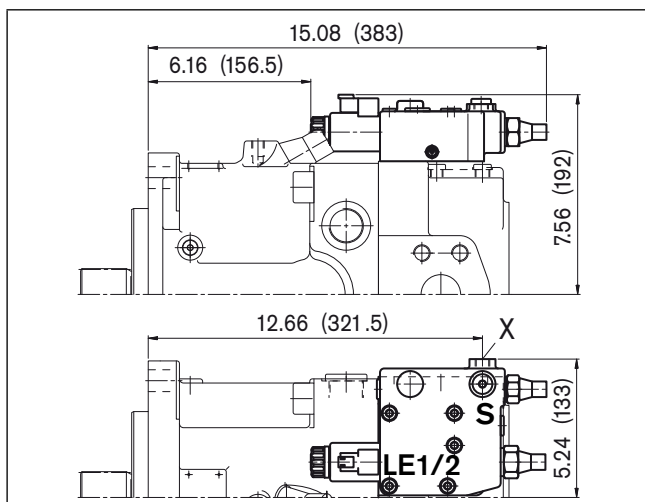

LE2S2/LE1S5/LE2S5

Power control with electric override (negative)
and load sensing control, override

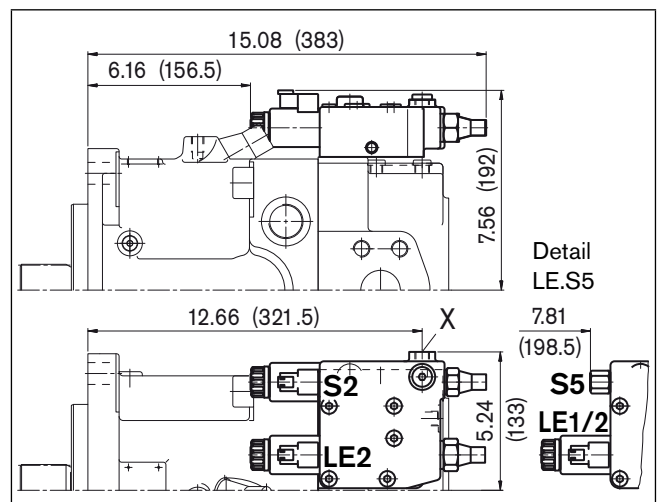

Dimensions size 260

Before finalizing your design,
please request a certified drawing.
Dimensions in inches and (millimeters).

LRDCS

Power control LR with pressure cut-off D, cross sensing control C and load sensing control S

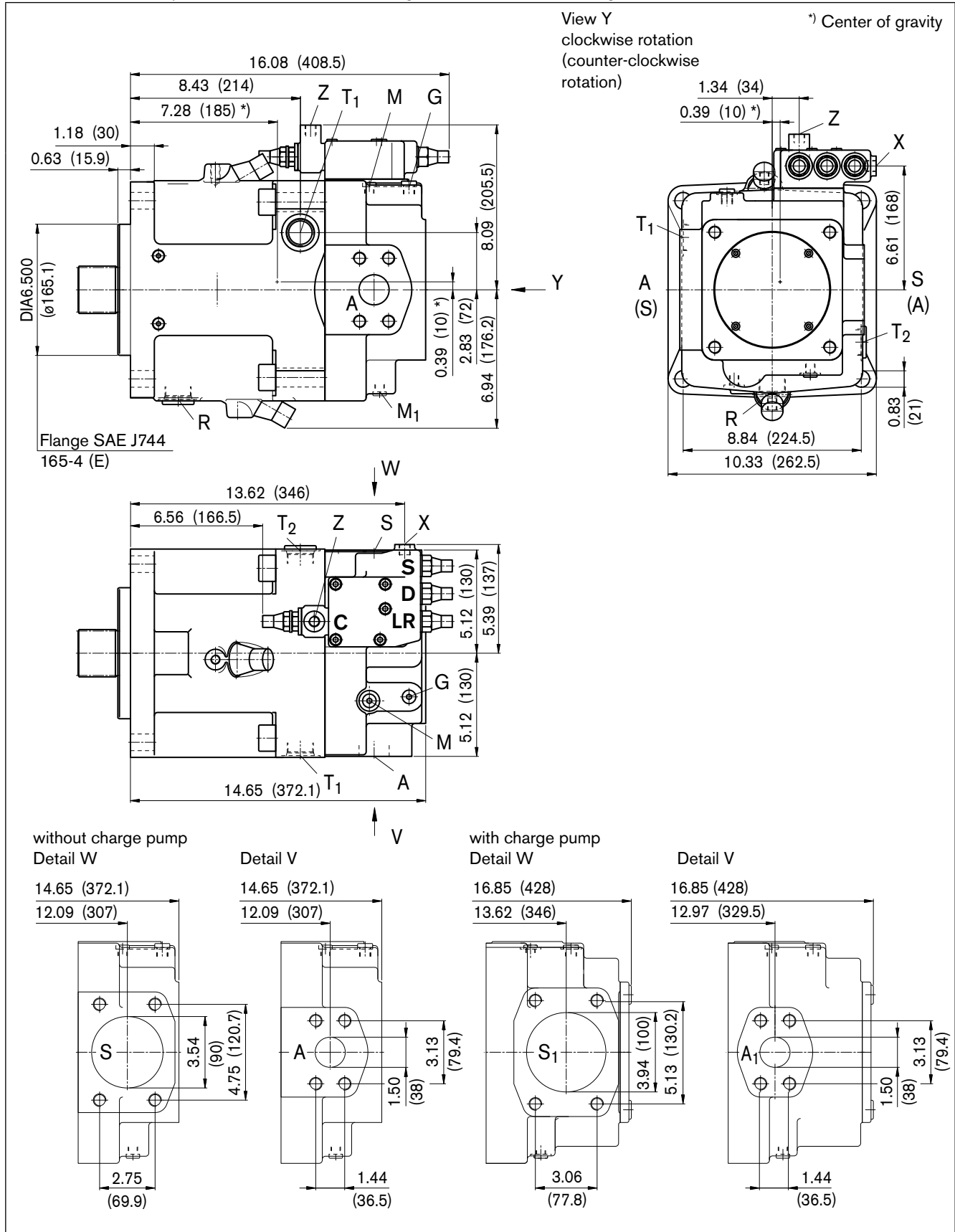

Dimensions size 260

Before finalizing your design,
please request a certified drawing.
Dimensions in inches and (millimeters).

Drive shaft

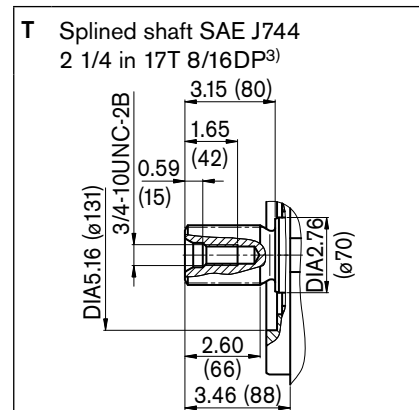
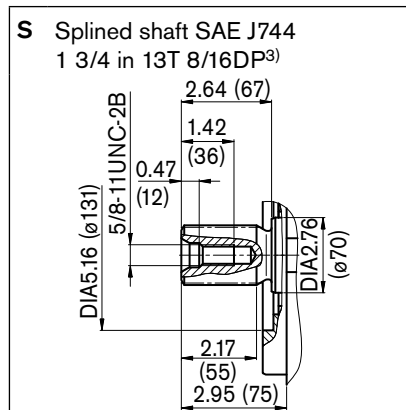
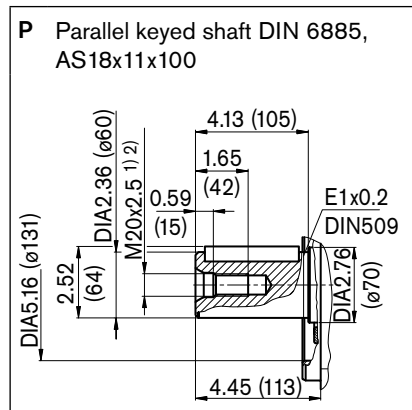

Ports

Designation	Function	Standard	Size ²⁾	Max. pressure [psi (bar)] ⁴⁾	State
A, A ₁	Service line port Fixing thread	SAE J518 ISO 68	1 1/2 in 5/8in-11UNC-2B;	0.83 (21) deep 5800 (400)	O
S	Suction port Fixing thread	SAE J518 ISO 68	3 1/2 in 5/8in-11UNC-2B;	0.94 (24) deep 435 (30)	O
S ₁	Suction port Fixing thread	SAE J518 ISO 68	4 in 5/8in-11UNC-2B;	0.83 (21) deep 30 (2) ⁶⁾	O
T ₁ , T ₂	Tank port	ISO 11926	1 5/16in-12UNF-2B;	0.63 (16) deep 145 (10)	⁵⁾
R	Air bleed	ISO 11926	1 5/16in-12UNF-2B;	0.63 (16) deep 145 (10)	X
M ₁	Measurement point, positioning chamber	ISO 11926	9/16in-18UNF-2B;	0.47 (12) deep 5800 (400)	X
M	Measurement point, service line port	ISO 11926	9/16in-18UNF-2B;	0.47 (12) deep 5800 (400)	X
X	Pilot pressure port in version with load sensing (S) and remote controlled pressure cut-off (G)	ISO 11926	9/16in-18UNF-2B;	0.47 (12) deep 5800 (400)	O
Y	Pilot pressure port in version with stroke limiter (H...), 2-stage pressure cut-off (E) and HD	ISO 11926	9/16in-18UNF-2B;	0.47 (12) deep 580 (40)	O
Z	Pilot pressure port in version with cross sensing (C) and power override (LR3) power override (LG1)	ISO 11926	9/16in-18UNF-2B;	0.47 (12) deep 5800 (400) 580 (40)	O
G	Port for control pressure (controller) in version with stroke limiter (H..., U2), HD and EP with screw union GE10 - PLM (otherwise closed)	ISO 11926	9/16in-18UNF-2B;	0.47 (12) deep 580 (40)	O

- 1) Center bore according to DIN 332 (thread acc. to DIN 13)
- 2) For maximum tightening torque, please refer to general notes on page 64
- 3) ANSI B92.1a-1976, 30° pressure angle, flat root, side fit, tolerance class 5
- 4) Depending on adjustment data and operating pressure
- 5) Depending on installation position, T1 or T2 must be connected (see also page 61)
- 6) with charge pump

O = Open, must be connected (closed on delivery)
X = Closed (in normal operation)

Dimensions size 260

Before finalizing your design,
please request a certified drawing.
Dimensions in inches and (millimeters).

LRDH1/LRDH5

Power control with pressure cut-off and hydraulic stroke limiter (negative characteristic)

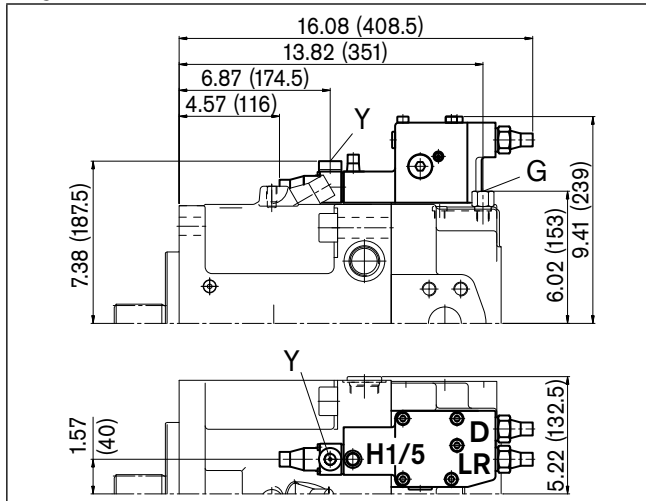

LRDH2/LRDH6

Power control with pressure cut-off and hydraulic stroke limiter (positive characteristic)

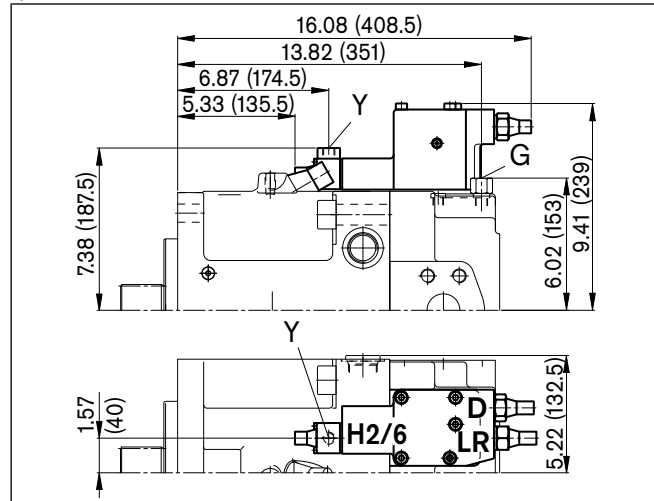

LRDU1/LRDU2

Power control with pressure cut-off and electric stroke limiter (positive characteristic)

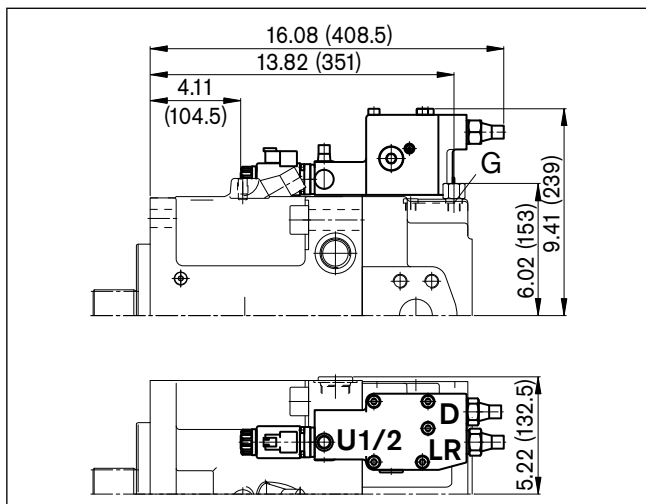

LR3DS

Power control with high-pressure related override, pressure cut-off and load sensing control

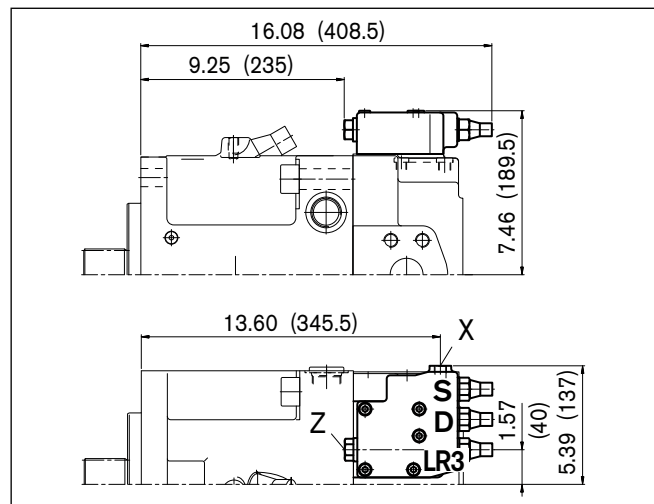

LG1EH

Power control with pilot-pressure related override (neg.), 2-stage pressure cut-off and hydr. stroke limiter

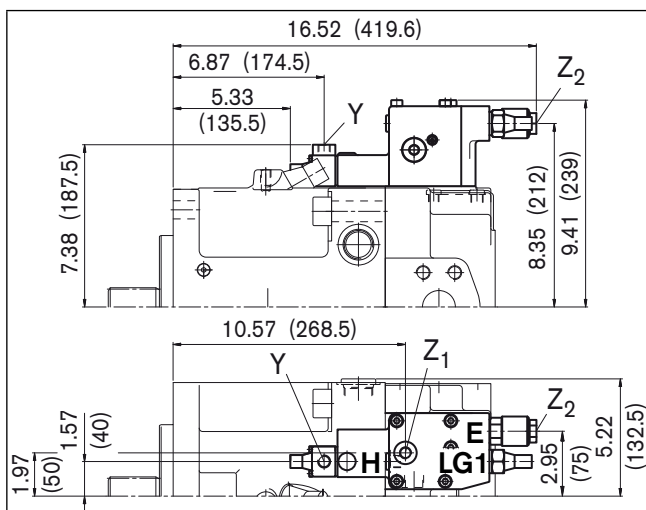

LG2EH

Power control with pilot-pressure related override (pos.), 2-stage pressure cut-off and hydr. stroke limiter

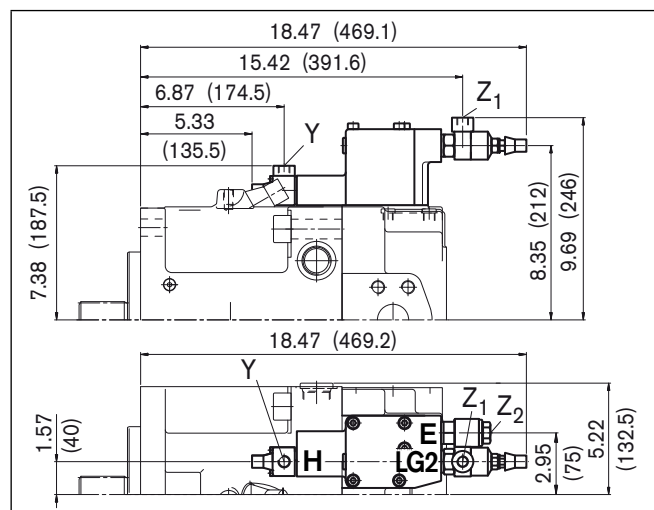

Dimensions size 260

Before finalizing your design,
please request a certified drawing.
Dimensions in inches and (millimeters).

HD1D/HD2D

Hydraulic control, pilot-pressure related with pressure cut-off

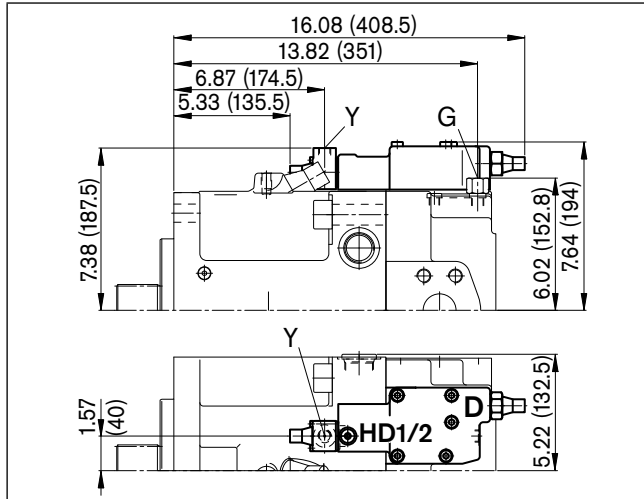

EP1D/EP2D

Electric control with proportional solenoid and pressure cut-off

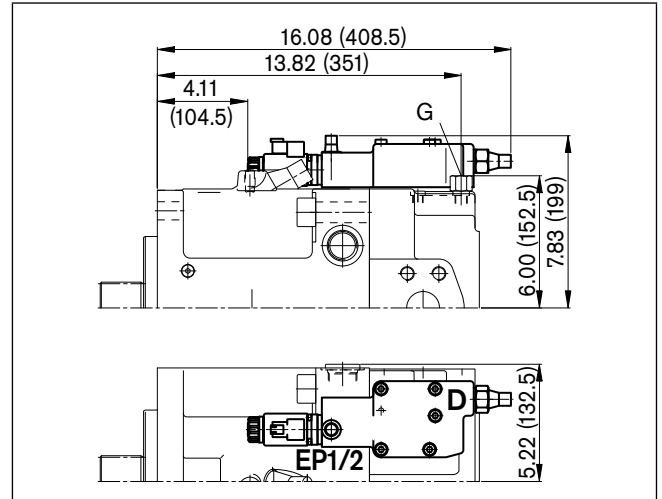

DRS/DRG

Pressure control with load sensing control
Pressure control remote controlled

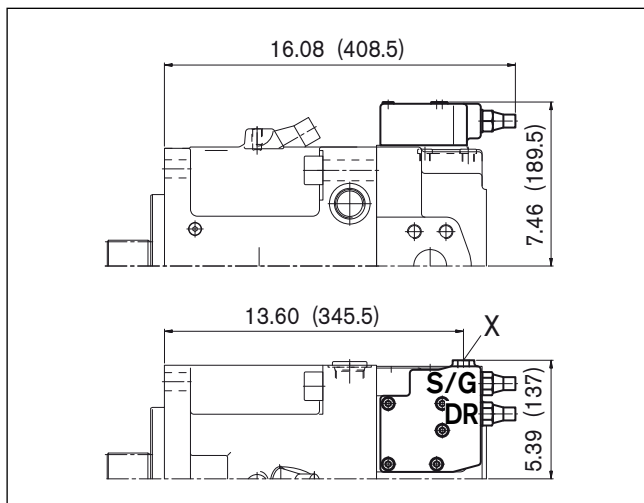

DRL

Pressure control for parallel operation

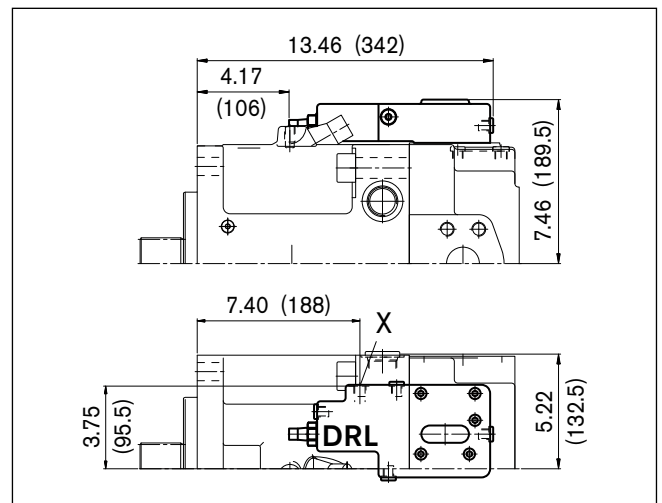

LE1S/LE2S

Power control with electric override (negative) and load sensing control

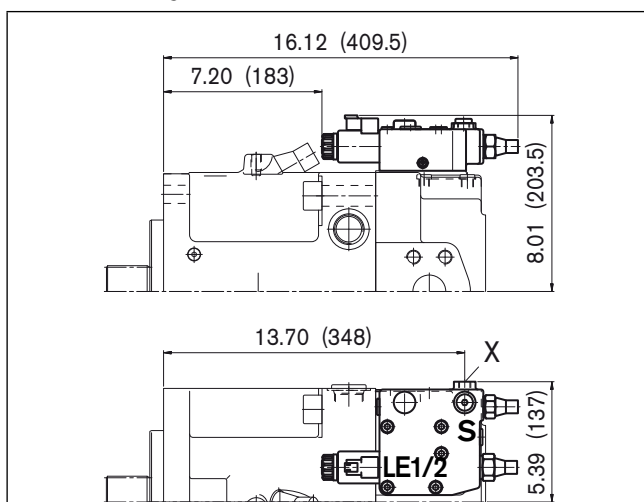

LE2S2/LE1S5/LE2S5

Power control with electric override (negative) and load sensing control, override

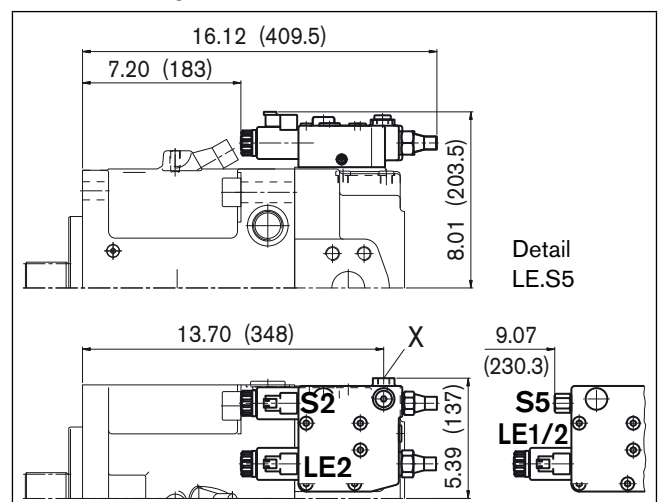

Through drive dimensions

Before finalizing your design, please request a certified drawing. Dimensions in inches and (millimeters).

Flange SAE J744 – 82-2 (A) Coupler for splined shaft acc. to ANSI B92.1a-1976 5/8 in 9T 16/32 DP¹⁾ (SAE J744 – 16-4 (A) **K01**
3/4 in 11T 16/32 DP¹⁾ (SAE J744 – 19-4 (A-B)) **K52**

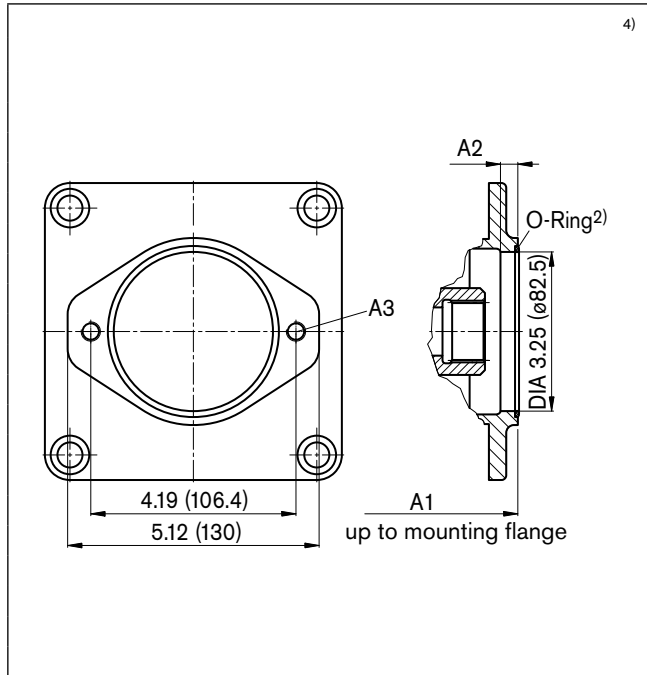

Size	A1		A2	A3 ³⁾	deep
	K01	K52			
40	9.45	9.45	0.32	3/8in-16UNC	0.59
	(240)	(240)	(8)		(15)
60	10.12	10.12	-		0.59
	(257)	(257)	-		(15)
75	10.83	10.83	-		0.59
	(275)	(275)	-		(15)
95	12.05	12.05	-		0.49
	(306)	(306)	-		(12.5)
130/145	12.95	12.95	-		0.49
	(329)	(329)	-		(12.5)
130/145*	14.29	14.29	-	0.49	
	(363)	(363)	-	(12.5)	
190	14.17	14.17	-	0.51	
	(359.8)	(359.8)	-	(13)	
190*	15.51	15.51	-	0.51	
	(394)	(394)	-	(13)	
260	15.16	15.16	-	0.51	
	(385)	(385)	-	(13)	
260*	16.82	16.82	-	0.51	
	(427.3)	(427.3)	-	(13)	

^{*)} Version with charge pump

Flange SAE J744 – 101-2 (B) Coupler for splined shaft acc. to ANSI B92.1a-1976 7/8 in 13T 16/32 DP¹⁾ (SAE J744 – 22-4 (B)) **K02**
1 in 15T 16/32 DP¹⁾ (SAE J744 – 25-4 (B-B)) **K04**

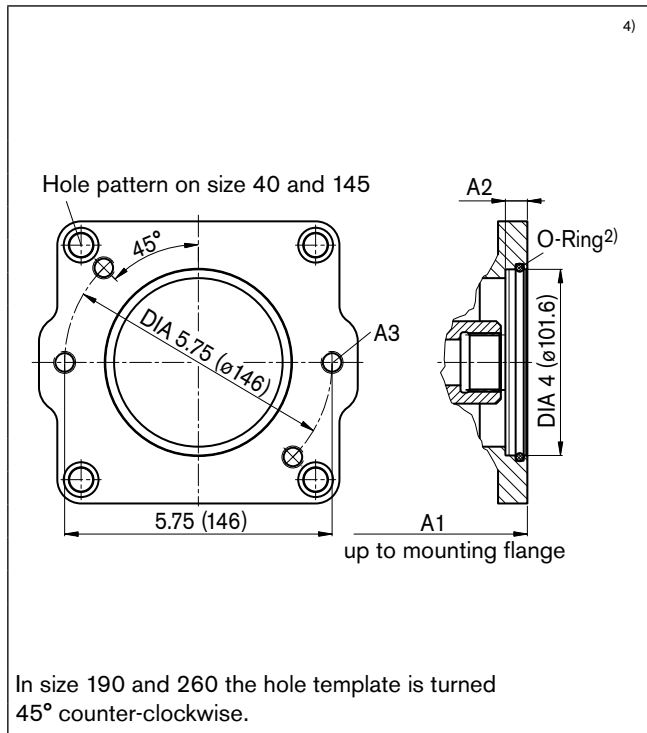

Size	A1		A2	A3 ³⁾	deep
	K02	K04			
40	9.61	9.61	0.39	1/2in-10UNC	0.75
	(244)	(244)	(10)		(19)
60	10.28	10.28	0.39		0.75
	(261)	(261)	(10)		(19)
75	10.98	10.98	0.39		0.75
	(279)	(279)	(10)		(19)
95	11.93	11.93	0.39		0.63
	(303)	(303)	(10)		(16)
130/145	12.83	12.83	0.39		0.63
	(326)	(326)	(10)		(16)
130/145*	14.17	14.17	0.39	0.63	
	(360)	(360)	(10)	(16)	
190	14.64	14.56	-	0.59	
	371.8	369.8	-	(15)	
190*	15.91	15.91	-	0.59	
	(404)	(404)	-	(15)	
260	15.55	15.55	-	0.59	
	(395)	(395)	-	(15)	
260*	17.22	17.22	-	0.59	
	(437.5)	(437.5)	-	(15)	

^{*)} Version with charge pump

Note

The mounting flange may be turned through 90°. Standard position as illustrated. Please state in clear text if required.

- 1) 30° pressure angle, flat root, side fit, tolerance class 5
- 2) O-ring included in the delivery contents
- 3) ISO 68, for maximum tightening torque, please refer to general notes on page 64
- 4) See page 59

Through drive dimensions

Before finalizing your design, please request a certified drawing. Dimensions in inches and (millimeters).

Flange SAE J744 – 127-2 (C) Coupler for splined shaft acc. to ANSI B92.1a-1976 1 1/4 in 14T 12/24 DP¹⁾ (SAE J744 – 32-4 (C)) **K07**
 1 1/2 in 17T 12/24 DP¹⁾ (SAE J744 – 38-4 (C-C)) **K24**

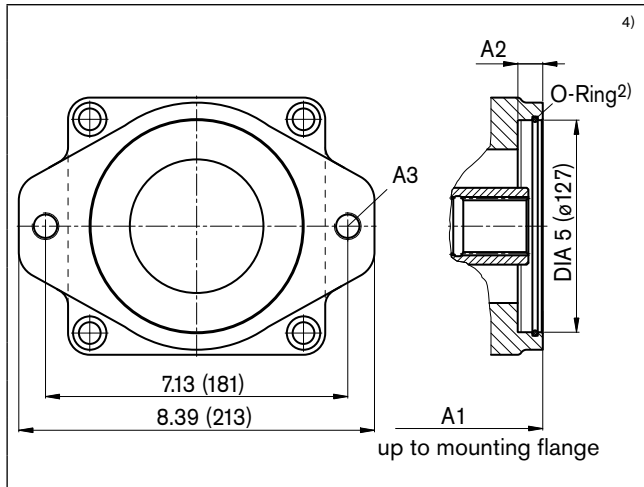

Size	A1		A2	A3 ³⁾	deep
	K07	K24			
60	10.71	–	0.51	5/8in-11UNC	0.79
	(272)	–	(13)		(20)
75	11.42	–	0.51		0.79
	(290)	–	(13)		(20)
95	12.52	12.52	0.51		0.79
	(318)	(318)	(13)		(20)
130/145	12.99	12.99	0.51	0.79	
	(330)	(330)	(13)	(20)	
130/145*	14.33	14.33	0.51	0.79	
	(364)	(364)	(13)	(20)	

^{*)} Version with charge pump

Flange SAE J744–127-2+4 (A) Coupler for splined shaft acc. to ANSI B92.1a-1976 1 1/4 in 14T 12/24 DP¹⁾ (SAE J744 – 32-4 (C)) **K07**
 1 1/2 in 17T 12/24 DP¹⁾ (SAE J744 – 38-4 (C-C)) **K24**

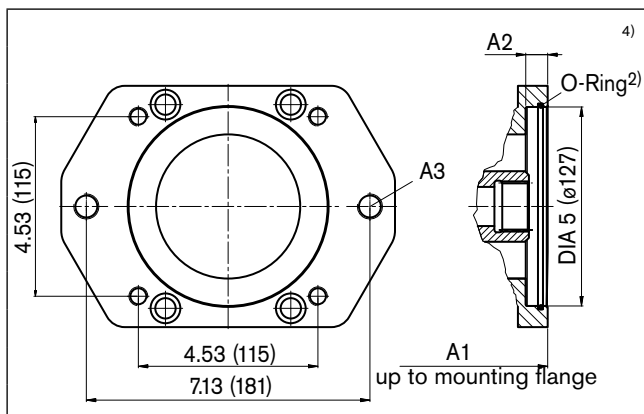

Size	A1		A2	A3 ³⁾	deep
	K07	K24			
190	14.48	14.48	0.51	5/8in-11UNC	0.75
	(367.8)	(367.8)	(13)		(19)
190*	15.75	15.75	0.51		0.75
	(400)	(400)	(13)		(19)
260	15.41	15.41	0.51		0.75
	(391.5)	(391.5)	(13)		(19)
260*	17.07	17.07	0.51	0.75	
	(433.5)	(433.5)	(13)	(19)	

^{*)} Version with charge pump

Note

The mounting flange may be turned through 90°. Standard position as illustrated. Please state in clear text if required.

- 1) 30° pressure angle, flat root, side fit, tolerance class 5
- 2) O-ring included in the delivery contents
- 3) ISO 68, for maximum tightening torque, please refer to general notes on page 64
- 4) See page 59

Through drive dimensions

Before finalizing your design, please request a certified drawing. Dimensions in inches and (millimeters).

Flange SAE J744 – 152-4 (D) Coupler for splined shaft acc. to ANSI B92.1a-1976 1 1/4 in 14T 12/24 DP¹⁾ (SAE J744 – 32-4 (C)) **K86**
 1 3/4 in 13T 8/16 DP¹⁾ (SAE J744 – 44-4 (D)) **K17**

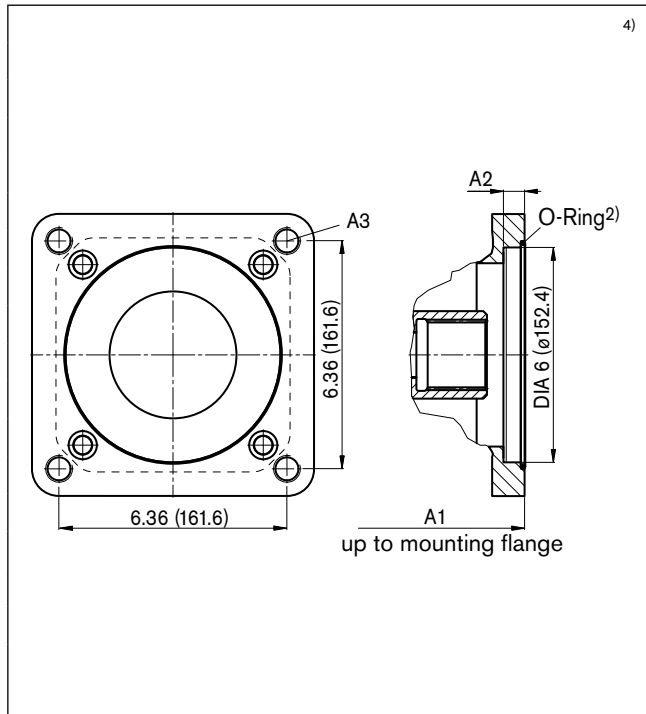

Size	A1		A2	A3 ³⁾	deep
	K86	K17			
75	11.42	–	0.51	3/4in-10UNC	1.10
	(290)	–	(13)		(28)
95	12.48	12.87	1.18		0.98
	(317)	(327)	(30)		(25)
130/145	13.39	13.78	1.18		0.98
	(340)	(350)	(30)		(25)
130/145*	14.72	15.12	1.18		0.98
	(374)	(384)	(30)		(25)
190	15.43	15.43	0.51		0.87
	(392)	(392)	(13)		(22)
190*	16.69	16.69	0.51	0.87	
	(424)	(424)	(13)	(22)	
260	16.42	16.42	0.51	0.87	
	(417)	(417)	(13)	(22)	
260*	18.07	18.07	0.51	0.87	
	(459)	(459)	(13)	(22)	

^{*)} Version with charge pump

Flange SAE J744 – 101-2 (E) Coupler for splined shaft acc. to ANSI B92.1a-1976 1 3/4 in 13T 16/32 DP¹⁾ (SAE J744 – 32-4 (C)) **K72**

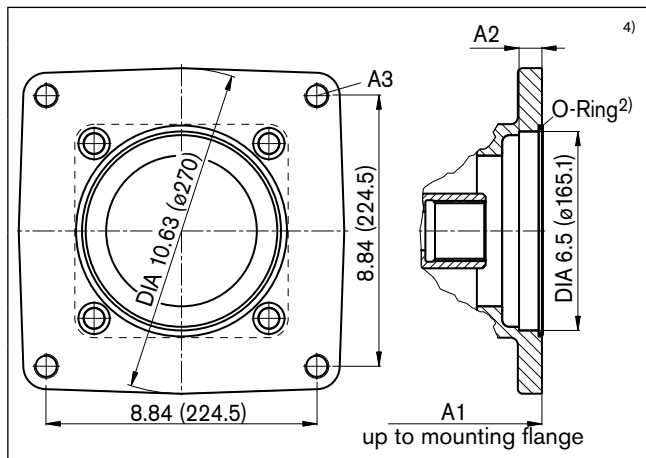

Size	A1		A2	A3 ³⁾	deep
	K72				
190	14.83	–	0.75	3/4in-10UNC	0.79
	(376.8)	–	(19)		(20)
190*	16.10	–	0.75		0.79
	(409)	–	(19)		(20)
260	16.42	–	0.75		0.79
	(417)	–	(19)		(20)
260*	18.07	–	0.75		0.79
	(459)	–	(19)		(20)

^{*)} Version with charge pump

Note

The mounting flange may be turned through 90°. Standard position as illustrated. Please state in clear text if required.

- 1) 30° pressure angle, flat root, side fit, tolerance class 5
- 2) O-ring included in the delivery contents
- 3) ISO 68, for maximum tightening torque, please refer to general notes on page 64
- 4) See page 59

Overview of attachments for AA11V(L)O

Through drive Flange	AA11VO		Attachment – 2nd pump							Through drive available for size
	Coupler for splined shaft	Code	AA11VO Size (shaft)	AA10V(S)O/31 Size (shaft)	A10V(S)O/53 Size (shaft)	A4FO Size (shaft)	AA4VG Size (shaft)	AA10VG Size (shaft)	External gear pump	
82-2 (A)	5/8 in	K01	–	18 (U)	10 (U)	–	–	–	Frame size F Size 4-22 ¹⁾	40...260
	3/4 in	K52	–	18 (S)	10 (S)	–	–	–	–	40...260
101-2 (B)	7/8 in	K02	–	28 (S, R) 45 (U)	28 (S, R) 45 (U, W)	16, 22, 28 (S)	–	18 (S)	Frame size N Size 20-32 ¹⁾ Frame size G Size 38-45 ¹⁾	40...260
	1 in	K04	40 (S)	45 (S, R)	45 (S, R) 60 (U, W)	–	28 (S)	28, 45 (S)	–	40...260
127-2 (C)	1 1/4 in	K07	60 (S)	71 (S, R) 100 (U)	60 (S) ²⁾ 85 (U)	–	40, 56, 71 (S)	63 (S)	–	60...260
	1 1/2 in	K24	–	100 (S)	85 (S)	–	–	–	–	95...260
152-4 (D)	1 1/4 in	K86	75 (S)	–	–	–	–	–	–	75...260
	1 3/4 in	K17	95, 130, 145 (S)	140 (S)	–	–	90, 125 (S)	–	–	130...260
165-4 (E)	1 3/4 in	K72	190, 260 (S)	–	–	–	180, 250 (S)	–	–	190...260

1) Rexroth recommends special versions of the gear pumps. Please ask.

2) Only A10VO with 4-hole mounting flange can be mounted to AA11V(L)O 190 and 260.

Combination pumps AA11VO + AA11VO

Before finalizing your design,
please request a certified drawing.
Dimensions in inches and (millimeters).

Total length A¹⁾

AA11VO 1st pump	2nd pump									
	Size 40	Size 60	Size 75	Size 95	Size 130/145	Size 130/145 ²⁾	Size 190	Size 190 ²⁾	Size 260	Size 260 ²⁾
Size 40	-	-	-	-	-	-	-	-	-	-
Size 60	19.29 (490)	19.96 (507)	-	-	-	-	-	-	-	-
Size 75	-	20.67 (525)	21.65 (550)	-	-	-	-	-	-	-
Size 95	20.79 (528)	22.05 (560)	22.72 (577)	23.78 (604)	-	-	-	-	-	-
Size 130/145	21.96 (551)	22.52 (572)	23.62 (600)	24.69 (627)	25.59 (650)	27.48 (698)	-	-	-	-
Size 130/145 ²⁾	23.03 (585)	23.86 (606)	24.96 (634)	26.02 (661)	26.93 (684)	28.82 (732)	-	-	-	-
Size 190	23.10 (586.8)	24.01 (609.8)	25.67 (652)	26.73 (679)	27.64 (702)	29.53 (750)	28.49 (723.6)	30.41 (772.3)	-	-
Size 190 ²⁾	24.37 (619)	25.28 (642)	26.93 (684)	27.99 (711)	28.90 (734)	30.79 (782)	29.76 (755.8)	31.67 (804.5)	-	-
Size 260	24.41 (620)	24.94 (633.5)	26.65 (677)	27.72 (704)	28.62 (727)	30.51 (775)	29.40 (746.8)	31.32 (795.5)	30.39 (772)	32.60 (828)
Size 260 ²⁾	26.08 (662.5)	26.59 (675.5)	28.31 (719)	29.37 (746)	30.28 (769)	32.17 (817)	31.07 (789.3)	32.99 (838)	32.07 (814.5)	34.27 (870.5)

1) When using the S shaft (splined shaft ANSI B92.1a - 1976) for the attached pump (2nd pump)

2) Version with charge pump

When ordering combination pumps, the type designations of the 1st and 2nd pumps must be connected by a "+".

Ordering code 1st pump + Ordering code 2nd pump

Ordering example:

AA11VO130LRDS/10R-NSD62K17 + AA11VO60LRDS/10R-NSC62N00

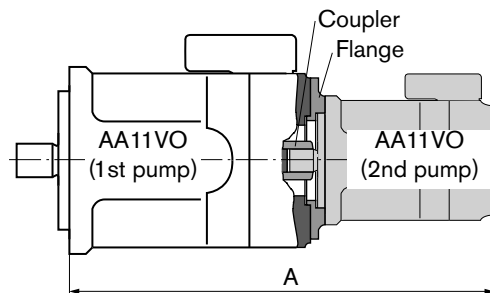

Swivel angle indicator

Before finalizing your design, please request a certified drawing. Dimensions in inches and (millimeters).

Optical swivel angle indicator, V

With the optical swivel angle indicator, a mechanical pointer on the side of the pump case displays the position of the swivel angle of the pump.

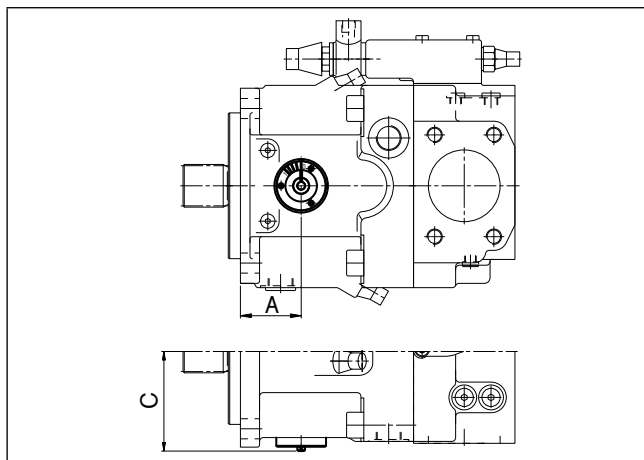
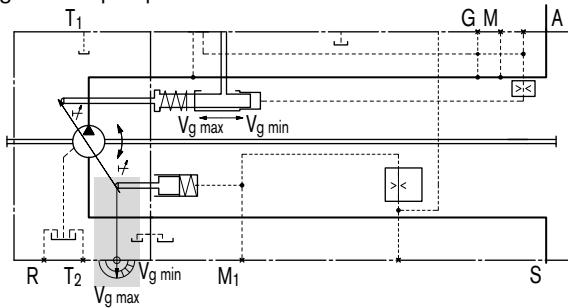

Size	A	C
40	1.99 (50.5)	3.31 (84.0)
60	not available	
75	2.39 (60.7)	3.82 (97.0)
95	2.50 (63.5)	4.09 (104.0)
130	2.79 (70.9)	4.41 (112.0)
190	3.45 (87.6)	4.86 (123.5)
260	3.45 (87.6)	5.39 (137.0)

Electric swivel angle sensor, R

With the electric swivel angle indicator the swivel position of the pump is measured by an electric swivel angle sensor. It has a robust, sealed case and integrated electronics designed for automotive applications.

As an output the Hall effect swivel angle sensor supplies a voltage signal proportional to the swivel angle (see technical parameters).

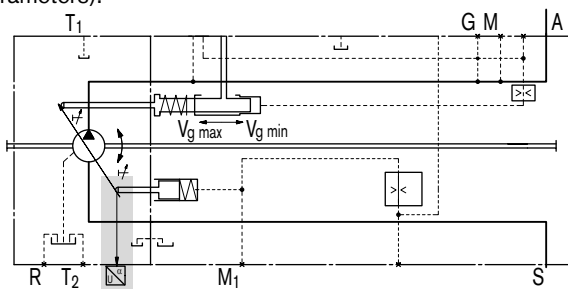

Parameters	
Supply voltage U_b	10...30 V DC
Output voltage U_a	2.5 V ($V_{g \min}$) 4.5 V ($V_{g \max}$)
Reverse-connect protection	Short-circuit-proof
EMC stability	Details on request
Operating temperature range	-40 °F to +257 °F (-40 °C to +125 °C)
Vibration resistance	
Sinusoidal vibration EN 60068-2-6	10 g / 5...2000 Hz
Shock resistance:	
Continuous shock IEC 68-2-29	25 g
Resistance to salt spray DIN 50021-SS	96 h
Type of protection DIN/EN 60529	IP67 and IP69K
Case material	synthetic material

Mating connector

AMP Superseal 1.5; 3-pin, Rexroth mat. no. R902602132

- Consisting of: AMP no.
- 1 female connector case, 3-pin _____ 282087-1
 - 3 single wire seals, yellow _____ 281934-2
 - 3 female connector contacts 0.07 to 0.13 in (1.8 to 3.3 mm) _____ 283025-1

The mating connector is not included in the delivery contents. This can be delivered by Rexroth on request.

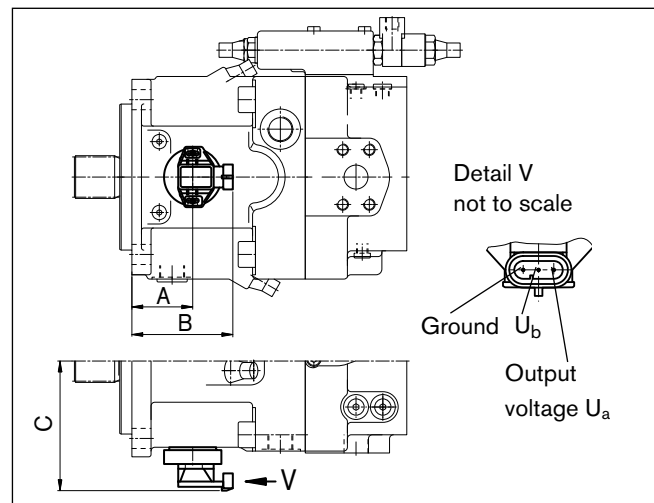

Size	A	B	C
40	1.99 (50.5)	3.48 (88.5)	4.66 (118.3)
60	not available		
75	2.39 (60.7)	3.89 (98.7)	5.17 (131.3)
95	2.50 (63.5)	4.00 (101.5)	5.44 (138.3)
130	2.79 (70.9)	4.29 (108.9)	5.76 (146.3)
190	3.45 (87.6)	4.94 (125.6)	6.21 (157.8)
260	3.45 (87.6)	4.94 (125.6)	6.74 (171.3)

Connector for solenoids

Before finalizing your design,
please request a certified drawing.
Dimensions in inches and (millimeters).

DEUTSCH DT04-2P-EP04, 2-pin

molded, without bidirectional suppressor diode
(standard) _____ P

Type of protection according to DIN/EN 60529:
IP67 and IP69K

Circuit diagram symbol

without bidirectional
suppressor diode

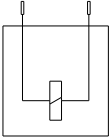

Mating connector

DEUTSCH DT06-2S-EP04
Rexroth mat. no. R902601804

Consisting of: _____ DT designation
 – 1 case _____ DT06-2S-EP04
 – 1 wedge _____ W2S
 – 2 female connectors _____ 0462-201-16141

The mating connector is not included in the delivery contents.
This can be delivered by Rexroth on request.

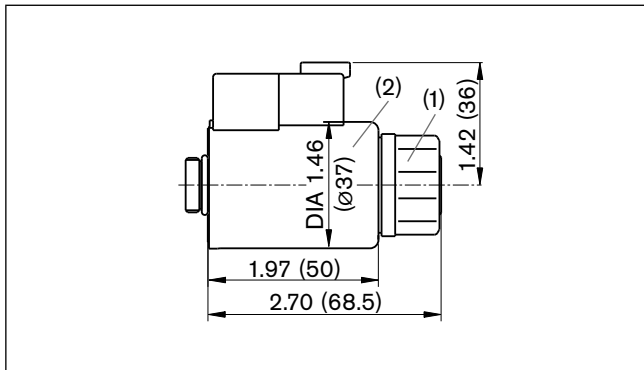

Note for round solenoids:

The position of the connector can be changed by turning the solenoid body.

Proceed as follows:

- 1. Loosen fixing nut (1)
- 2. Turn the solenoid body (2) to the desired position.
- 3. Tighten the fixing nut
Tightening torque of fixing nut: 3.69^{+0.74} lb-ft (5⁺¹ Nm)
(width across the flats WAF 26, 12kt DIN 3124)

Installation notes

Before finalizing your design, please request a certified drawing. Dimensions in inches and (millimeters).

General

During commissioning and operation, the axial piston unit must be filled with hydraulic fluid and air bled. This is also to be observed following a relatively long standstill as the system may empty via the hydraulic lines.

The case drain in the case interior must be directed to the tank via the highest tank port (T_1, T_2). The minimum suction pressure at port S must not fall below 12 psi (0.8 bar) absolute (without charge pump) or 9 psi (0.6 bar) (with charge pump).

In all operational conditions, the suction line and case drain line must flow into the tank below the minimum fluid level.

Installation position

See examples below. Additional installation positions are available upon request.

Below-tank installation (standard)

Pump below the minimum fluid level of the tank.

Recommended installation positions: 1 and 2.

Above-tank installation

Pump above the minimum fluid level of the tank.

Observe the maximum permissible suction height $h_{s \max} = 31.50$ in (800 mm).

The version AA11VLO (with charge pump) is not designed for installation above the tank.

Recommendation for installation position 7 (shaft up): A check valve in the case drain line (opening pressure 7.5 psi (0.5 bar)) can prevent the case interior from draining.

For control options with pressure control, displacement limiters, HD and EP control, the minimum displacement setting must be $V_g \geq 5\% V_{g \max}$.

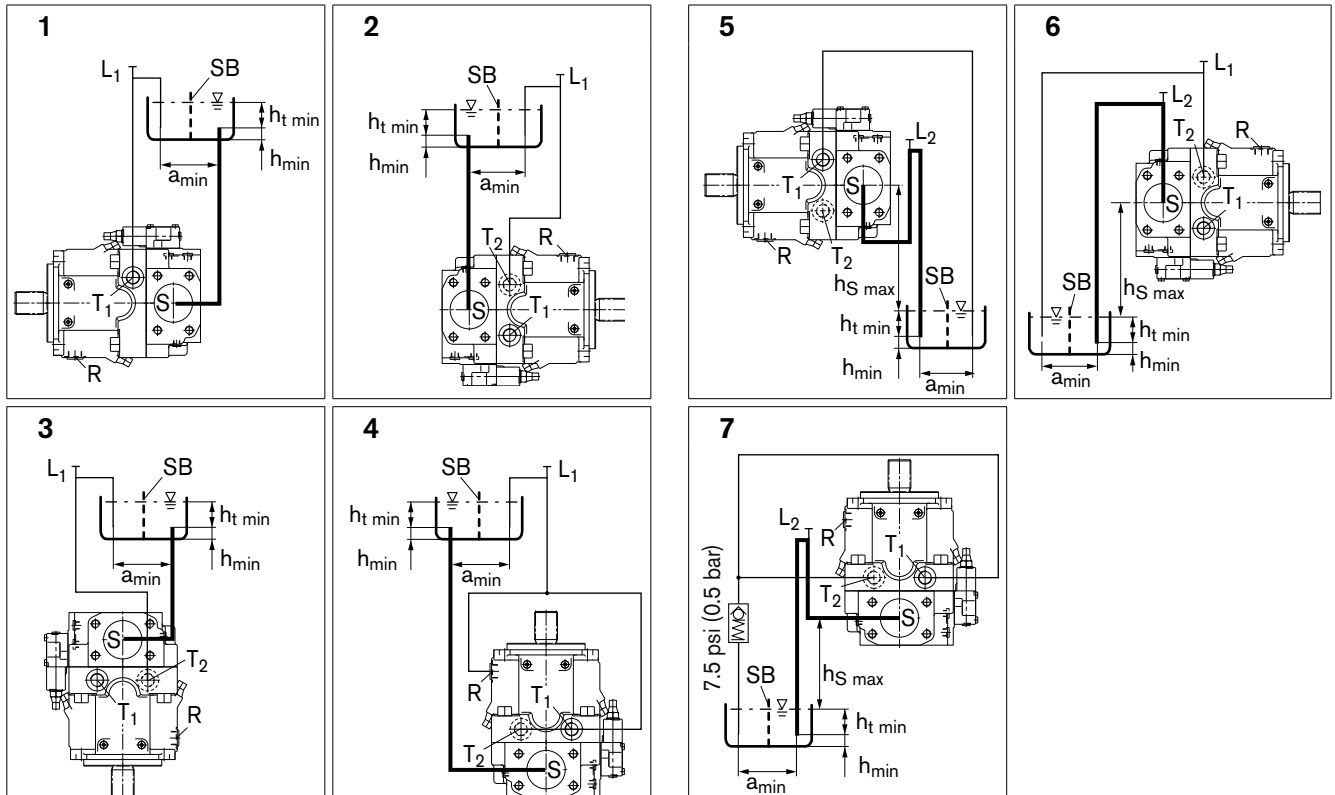

$h_{s \max} = 31.50$ in (800 mm), $h_{t \min} = 7.87$ in (200 mm), $h_{\min} = 3.94$ in (100 mm), SB = Silencer plate (baffle plate)

When designing the tank, ensure adequate space a_{\min} between the suction line and the case drain line to prevent the heated, returned fluid from being directly drawn back out.

Installation position	Air bleeding	Filling
1	T_1	$S + T_1$
2	R	$S + T_2$
3	T_1/T_2	$S + T_1/T_2$
4	R	$S + T_1/T_2$

Installation position	Air bleeding	Filling
5	$L_1 + L_2$	$L_2 (S) + L_1 (T_1)$
6	$R + L_2$	$L_2 (S) + L_1 (T_2)$
7	$L_1 + L_2$	$L_2 (S) + L_1 (T_1/T_2)$

Installation Notes

Tank installation

Pump below the minimum fluid level in the tank.

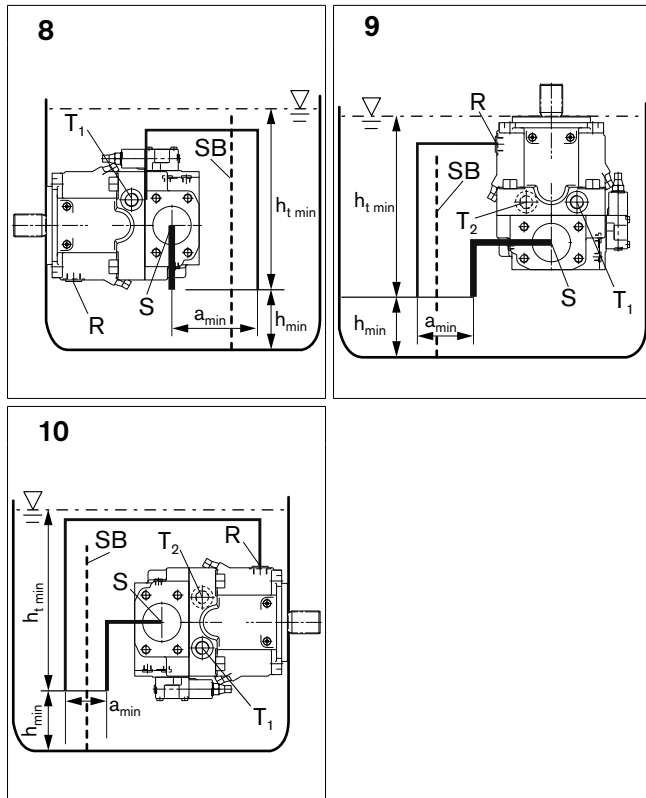

$h_{s\ max} = 31.50\ \text{in}\ (800\ \text{mm})$, $h_{t\ min} = 7.87\ \text{in}\ (200\ \text{mm})$,
 $h_{min} = 3.94\ \text{in}\ (100\ \text{mm})$, SB = Silencer plate (baffle plate)

When designing the tank, ensure adequate space a_{min} between the suction line and the case drain line to prevent the heated, returned fluid from being directly drawn back out.

Installation position	Air bleeding	Filling
8	T ₁	automatically via all open T ₁ , T ₂ , R and S
9	R	ports, though position below the hydraulic fluid level
10	R	

Notice

General notes

- The AA11VO pump is designed to be used in open circuits.
- Project planning, assembly and commissioning of the axial piston unit require the involvement of qualified personnel.
- The service line ports and function ports are only designed to accommodate hydraulic lines.
- During and shortly after operation, there is a risk of burns on the axial piston unit and especially on the solenoids. Take appropriate safety measures (e. g. by wearing protective clothing).
- Depending on the operational state of the axial piston unit (operating pressure, fluid temperature), the characteristic may shift
- Pressure ports:
The ports and fixing threads are designed for the specified maximum pressure. The machine or system manufacturer must ensure that the connecting elements and lines correspond to the specified operating conditions (pressure, flow, hydraulic fluid, temperature) with the necessary safety factors.
- The data and notes contained herein must be adhered to.
- The following tightening torques apply:
 - Threaded hole for axial piston unit:
The maximum permissible tightening torques $M_{G\max}$ are maximum values for the threaded holes and must not be exceeded. For values, see the following table.
 - Fittings:
Observe the manufacturer's instruction regarding the tightening torques of the used fittings.
 - Fixing screws:
For fixing screws according to ISO 68, we recommend checking the tightening torque individually according to VDI 2230.
 - Locking screws:
For the metal locking screws supplied with the axial piston unit, the required tightening torques of locking screws M_V apply. For values, see the following table.
- The product is not approved as a component for the safety concept of a general machine according to DIN EN ISO 13849.

Thread size		Max. permissible tightening torque of the screw thread $M_{G\max}$	Required tightening torque for locking screws M_V	WAF Hexagon socket
9/16in-18UNF-2B	ISO 11926	80 Nm	25 Nm	1/4 in
7/8in-14UNF-2B	ISO 11926	240 Nm	127 Nm	3/8 in
1 1/16in-12UNF-2B	ISO 11926	360 Nm	147 Nm	9/16 in
1 5/16in-12UNF-2B	ISO 11926	540 Nm	198 Nm	5/8 in