



aerospace  
climate control  
electromechanical  
filtration  
fluid & gas handling  
**hydraulics**  
pneumatics  
process control  
sealing & shielding



## PGP/PGM 600 Series

Gear Pumps and Motors In  
Single And Multiple Configurations



ENGINEERING YOUR SUCCESS.

## **The Parker Hannifin Gear Pump Division Assures:**

- Consistent quality
- Technical innovation
- Premier customer service

## **Worldwide Sales and Service**

Parker operates sales and service centers in major industrial areas worldwide. Call 1-800-C-PARKER for more information, or for a synopsis of the Gear Pump Division, contact a Parker representative.

The Gear Pump Division's ability to engineer specialty products for unique applications has kept us at the forefront of technology, and ensured our position as the industry leader. Our success has come from providing a quality product with excellent sales and service support.

We manufacture hydraulic components for a wide range of industries including:

- Construction
- Truck/Bus
- Material handling
- Forestry
- Agriculture
- Industrial
- Turf care



### **WARNING**

FAILURE OR IMPROPER SELECTION OR IMPROPER USE OF THE PRODUCTS AND/OR SYSTEMS DESCRIBED HEREIN OR RELATED ITEMS CAN CAUSE DEATH, PERSONAL INJURY AND PROPERTY DAMAGE.

This document and other information from Parker Hannifin Corporation, its subsidiaries and authorized distributors provide product and/or system options for further investigation by users having technical expertise. It is important that you analyze all aspects of your application and review the information concerning the product or system in the current product catalog. Due to the variety of operating conditions and applications for these products or systems, the user, through its own analysis and testing, is solely responsible for making the final selection of the products and systems and assuring that all performance, safety and warning requirements of the application are met.

The products described herein, including without limitation, product features, specifications, designs, availability and pricing, are subject to change by Parker Hannifin Corporation and its subsidiaries at any time without notice.

### **Offer of Sale**

The items described in this document are hereby offered for sale by Parker Hannifin Corporation, its subsidiaries or its authorized distributors. This offer and its acceptance are governed by the provisions stated in the "Offer of Sale".

© Copyright 2008, Parker Hannifin Corporation, All Rights Reserved.

**Table of Contents**

**SERIES 600:**

**Description and Characteristics** ..... 3

    Features ..... 4

    Construction (Exploded/Cross Section View) ..... 5

    PGP/PGM 610 Ordering Code ..... 6

    PGP/PGM 610 Dimensions ..... 7

    PGP/PGM 620 Ordering Code ..... 8

    PGP/PGM 620 Dimensions ..... 9

    PGP/PGM 640 Ordering Code ..... 10

    PGP/PGM 640 Dimensions ..... 11

    Spline Shaft Options ..... 12

    Key Shaft Options ..... 13

    Mounting Flange Options ..... 15

    Port Options ..... 16

    Performance Data ..... 17

    Fluid Recommendations ..... 20

**Offer of Sale** ..... 22

**Pump/Motor Products**

**PGP/PGM 610**

- ▶ *Continuous pressures to 275 bar / 4000 psi*
- ▶ *Displacements from 7 to 32 cc/rev (.43 to 1.95 cir)*
- ▶ *SAE B 13-tooth spline available*
- ▶ *Integral valve options*

**PGP/PGM610**



**PGP/PGM 620**

- ▶ *Continuous pressures to 275 bar / 4000 psi*
- ▶ *Displacements from 19 to 50 cc/rev (1.16 to 3.05 cir)*
- ▶ *Multiple sections and cross frames with common inlet*
- ▶ *Integral valve options*

**PGP/PGM620**

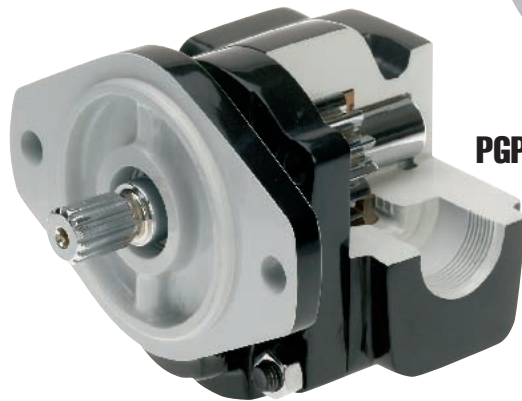

**PGP/PGM 640**

- ▶ *Continuous pressures to 275 bar / 4000 psi*
- ▶ *Displacements from 30 to 80 cc/rev (1.83 to 4.88 cir)*
- ▶ *Multiple sections and cross frames with common inlet*
- ▶ *Integral valve options*

**PGP/PGM640**



**Features of PGP/PGM600 Series**

**PGP/PGM 600**

Parker Hydraulics has supplied gear pumps and motors to worldwide mobile and industrial markets for many years, especially for material handling, turf care, agricultural, and construction equipment applications. Many Parker pumps and motors have been developed and tested for the specific needs of these industries.

Parker's defined strategy to provide engineered solutions, coupled with an award-winning flexible manufacturing system has resulted in the availability of a wide range of special options.

**Features of PGP/PGM 600**

- Interlocking body design
- Multiple section and cross-frame pumps available
- Common inlets available for multiple section pumps
- Continuous operating pressures up to 275 bar (4000 psi)
- Pressure balanced thrust plate design for high efficiency

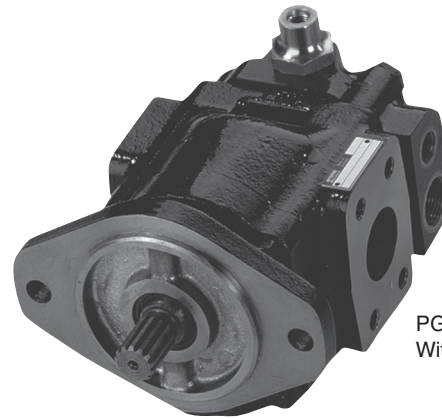

PGP620  
With LS Priority

- Reduced system noise levels compared to earlier models and competitors' pumps
- High power through-drive capability
- Wide range of integral valves for power steering, power brakes, fan drives and implement hydraulics

**Characteristics**

Product Features	Description
<b>Pump/motor type</b>	Heavy-duty, cast iron, external gear.
<b>Mounting</b>	SAE, 2-bolt and 4-bolt
<b>Ports</b>	SAE split flange, straight thread o-ring
<b>Shaft style</b>	SAE splined, keyed, tapered.
<b>Speed range</b>	See tables, pages 17-19
<b>Displacement</b>	See codes pages 6,8,10
<b>Rotation</b>	Clockwise, counterclockwise or birotational.
<b>Pump inlet pressure</b>	1.0 bar (15 psig) Maximum 13 cm (5 in) Hg Maximum Vacuum at operating temperature
<b>Inlet flow velocity</b>	3.0 mps (10 fps) Max Pump
<b>Outlet pressure</b>	See pages 7, 9, 11
<b>Axial / radial shaft loads</b>	Call product support, call 1-888-700-7411
<b>Hydraulic fluids</b>	Petroleum oil (mineral base) Biodegradable oil Fire resistant fluids such as: - water-oil emulsions 60/40, HFB - water-glycol, HFC - phosphate-esters, HFD Note: Pressure ratings are reduced by 35 bar (500 psi) when using water-oil emulsions or water glycol, see pages 20-21 for details.
<b>Fluid temperature</b>	Range of operating temperature -15 to +80°C (5 to 176°F). Temperature for cold start -20 to -15°C (-4 to +5°F) at speed ≤ 1500 rpm. Maximum permissible operating pressure is dependent on fluid temperature.

Product Features	Description
<b>Recommended fluid viscosity (petroleum oil)</b>	Range of operating viscosity 15 to 75 cSt. Max. operating viscosity should not exceed 1600 cSt. Recommended min. viscosity 8 cSt. See pages 20-21 for more details.
<b>Recommended filtration</b>	According to ISO 4406 code. 20/18/15 at 140 bar (2000psi) 19/17/14 at 210 bar (3000psi) 17/15/12 at 275 bar (4000psi)
<b>Multiple pump assemblies</b>	- Available in two or three section configurations. - Max. shaft loading must conform to the limitations shown in the Shaft Load Capacity table, see page 14. - The max. load is determined by adding the torque values for each pumping section that will be simultaneously loaded.
<b>Separate or common inlet capability</b>	Separate Inlet configuration: - Each gear housing has individual inlet and outlet ports.  Common Inlet configuration: - Two or more gear sets share a common inlet.
<b>Valve options</b>	-Load sensing priority -Constant primary flow priority -Relief valves -Anti-cav checks (motor)

### PGP/PGM 600 Series Construction

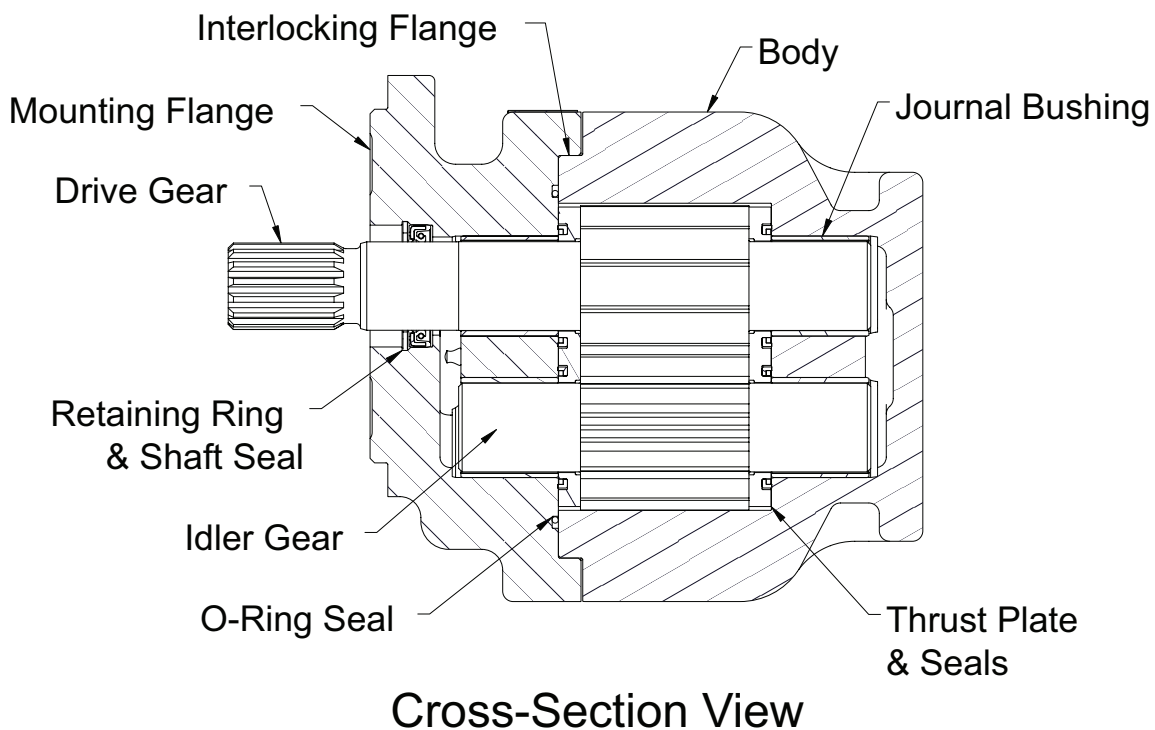
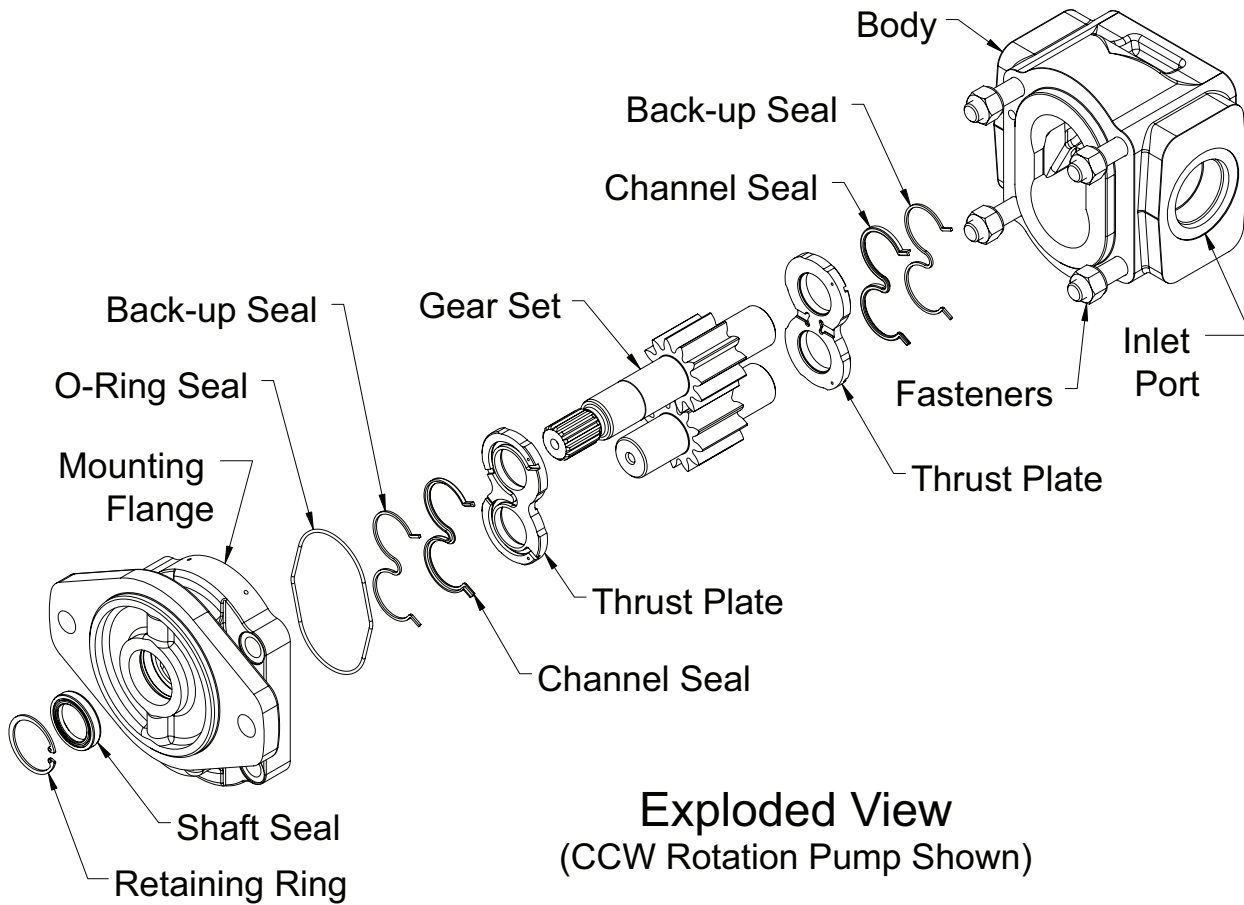

**PGP/PGM 610 How to Specify**

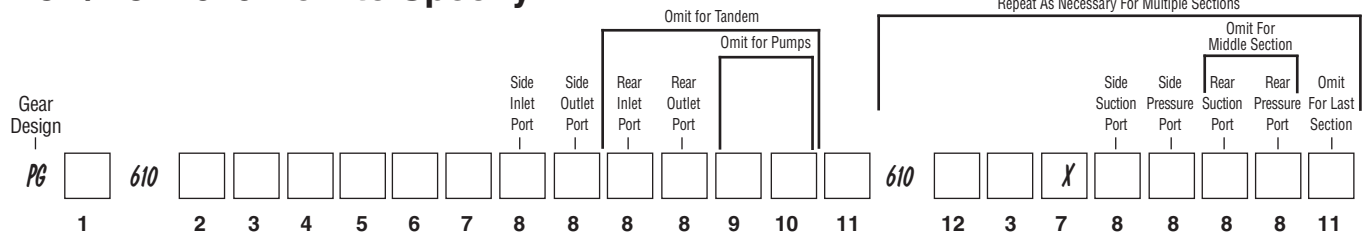

1 Pump/Motor	
<b>P</b>	Pump
<b>M</b>	Motor

2 Unit		
	Pump	Motor
<b>A</b>	Single unit	Standard Motor w/o checks
<b>B</b>	Multiple unit	Standard Motor w/ two checks
<b>C</b>	—	Standard Motor w/one anti cavitation check (ACC)

3 Displacement	
<b>0070</b>	7 cc/rev (0.43 in <sup>3</sup> /rev)
<b>0100</b>	10 cc/rev (0.61 in <sup>3</sup> /rev)
<b>0140</b>	14 cc/rev (0.85 in <sup>3</sup> /rev)
<b>0160</b>	16 cc/rev (0.98 in <sup>3</sup> /rev)
<b>0180</b>	18 cc/rev (1.10 in <sup>3</sup> /rev)
<b>0210</b>	21 cc/rev (1.28 in <sup>3</sup> /rev)
<b>0230</b>	23 cc/rev (1.40 in <sup>3</sup> /rev)
<b>0260</b>	26 cc/rev (1.59 in <sup>3</sup> /rev)
<b>0280</b>	28 cc/rev (1.71 in <sup>3</sup> /rev)
<b>0320</b>	32 cc/rev (1.95 in <sup>3</sup> /rev)

4 Rotation	
<b>C</b>	Clockwise
<b>A</b>	Counter clockwise
<b>B</b>	Bi-directional (Motor Only)

5 Shaft*	
<b>A1</b>	9T, SAE "A" spline
<b>C1</b>	11T, SAE 19-4 spline
<b>D1</b>	13T, SAE "B" spline
<b>K1</b>	32L, SAE "A" parrallel
<b>L6</b>	32L, SAE "19-1" parrallel

\*See Note 1

6 Flange	
<b>H2</b>	SAE "A" 2-bolt
<b>H3</b>	SAE "B" 2-bolt

7 Shaft Seal*	
<b>X</b>	No seal
<b>N</b>	NBR (Buna-N) (pump only)
<b>V</b>	FPM, FKM (Fluorocarbon) (pump only)
<b>M</b>	Double NBR (Buna-N) (pump only)
<b>W</b>	Double FPM (Fluorocarbon) (pump only)
<b>H</b>	High Pres. (7bar) (motor only)

\*See Note 2

9 Motor Drain Option	
<b>B1</b>	No drain
<b>A</b>	SAE-4, straight thread o-ring
<b>C</b>	SAE-6, straight thread o-ring

10 Motor Drain Position	
<b>4</b>	Rear drain

11 Inlet Options (Multi Section Units Only)	
<b>C</b>	Common
<b>S</b>	Separate

12 Multiple Unit	
<b>A</b>	Last section
<b>B</b>	Middle section

8 Port Options*			
Code	Description	Rear Ports	Available Displacements for Side Ports
<b>B1</b>	No ports	n/a	7 thru 32 cc
<b>D3</b>	SAE-8 straight thread o-ring	Yes	7 thru 32 cc
<b>D4</b>	SAE-10 straight thread o-ring	Yes	7 thru 32 cc
<b>D5</b>	SAE-12 straight thread o-ring	Yes	7 thru 32 cc
<b>D6</b>	SAE-16 straight thread o-ring	No	7 thru 32 cc
<b>D7</b>	SAE-20 straight thread o-ring	No	14 thru 32 cc
<b>S1</b>	½" Split Flange, SAE Code 61	No	7 thru 32 cc
<b>S2</b>	¾" Split Flange, SAE Code 61	No	7 thru 32 cc
<b>S3</b>	1" Split Flange, SAE Code 61	No	14 thru 32 cc
<b>S4</b>	1¼" Split Flange, SAE Code 61	No	14 thru 32 cc

\*See Note 3

**Notes:**

1. See shaft load capacity table, page 14, to check shaft strength.
2. Specify "V" or "W" code if phosphate ester fluid is used or if operating temperatures exceed 80°C (176°F).
3. See page 16 for recommended maximum flows.

**PGP/PGM 610 Specification - Standard Displacements - Single Unit**

Pump Displacement	Code	0070	0100	0140	0160	0180	0210	0230	0260	0280	0320
	cc/rev	7.0	10.0	14.0	16.0	18.0	21.0	23.0	26.0	28.0	32.0
	in <sup>3</sup> /rev	0.43	0.61	0.85	0.98	1.10	1.28	1.40	1.59	1.71	1.95
Continuous Pressure	bar	275	275	275	275	265	245	235	215	200	175
	psi	3989	3989	3989	3989	3843	3553	3408	3118	2901	2538
Intermittent Pressure	bar	300	300	300	300	290	270	260	240	220	175
	psi	4351	4351	4351	4351	4206	3916	3771	3480	3190	2538
Port Location "X"	mm	71.0	75.5	75.0	78.0	81.0	81.5	83.5	81.0	84.0	90.5
	inch	2.80	2.97	2.95	3.07	3.19	3.21	3.29	3.19	3.31	3.56
Overall Length "Y"	mm	99.0	103.5	109.5	112.5	115.5	120.0	122.0	123.5	126.5	135.0
	inch	3.90	4.07	4.31	4.43	4.55	4.72	4.80	4.86	4.98	5.31
Weight*	kg	5.9	6.2	6.5	6.8	6.8	7.1	7.2	7.3	7.5	8.0
	lb	13.1	13.6	14.4	14.9	15.0	15.6	15.9	16.2	16.5	17.6

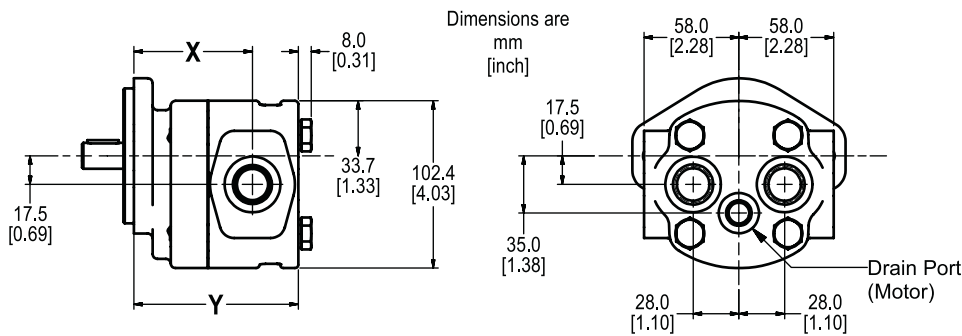

**PGP/PGM 610 Specification - Standard Displacements - Tandem Unit**

Pump Displacement	Code	0070	0100	0140	0160	0180	0210	0230	0260	0280	0320
	cc/rev	7.0	10.0	14.0	16.0	18.0	21.0	23.0	26.0	28.0	32.0
	in <sup>3</sup> /rev	0.43	0.61	0.85	0.98	1.10	1.28	1.40	1.59	1.71	1.95
Front Port Location "X1"	mm	71.0	75.5	75.0	78.0	81.0	81.5	83.5	81.0	84.0	90.5
	inch	2.80	2.97	2.95	3.07	3.19	3.21	3.29	3.19	3.31	3.56
Front Overall Length "Y1"	mm	96.0	100.5	106.5	109.5	112.5	117.0	119.0	120.5	123.5	132.5
	inch	3.78	3.96	4.19	4.31	4.43	4.61	4.69	4.74	4.86	5.22
Rear Port Location "X2"	mm	25.0	25.0	31.5	31.5	31.5	35.5	35.5	39.5	39.5	42.0
	inch	0.98	0.98	1.24	1.24	1.24	1.40	1.40	1.56	1.56	1.65
Rear Overall Length "Y2"	mm	95.5	100.0	106.0	109.0	112.0	116.5	118.5	120.0	123.0	132.0
	inch	3.76	3.94	4.17	4.29	4.41	4.59	4.67	4.72	4.84	5.20
Weight - Front Section*	kg	5.6	5.9	6.2	6.4	6.5	6.8	6.9	7.0	7.2	7.7
	lb	12.4	12.9	13.7	14.2	14.3	14.9	15.2	15.5	15.8	17.0
Weight - Rear Section*	kg	5.7	5.9	6.3	6.5	6.5	6.8	7.0	7.1	7.2	7.8
	lb	12.5	13.0	13.8	14.3	14.4	15.0	15.3	15.6	15.9	17.2

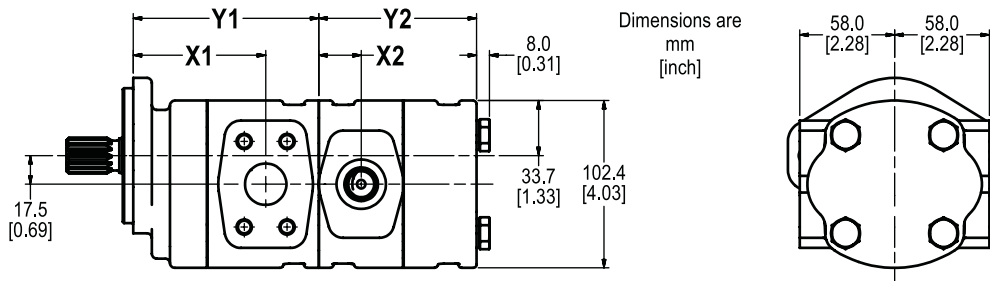

\*All weights are approximate. The actual weight of an assembly will depend upon the porting and the type of shaft and mounting specified. The weight of a tandem pump will be the sum of the weights of each section.

**PGP/PGM 620 How to Specify**

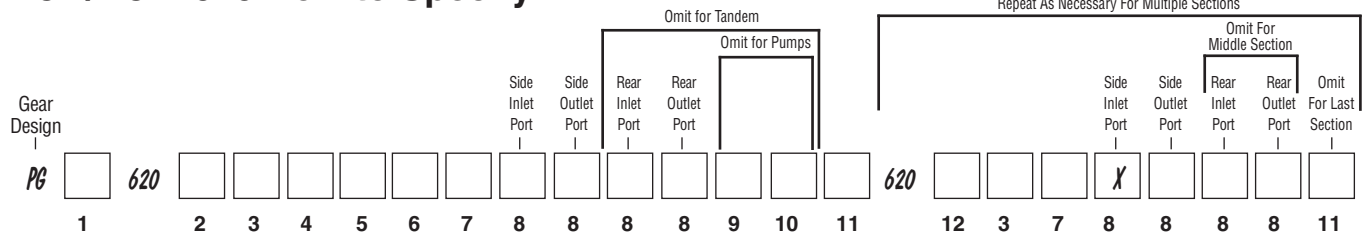

1 Pump/Motor	
<b>P</b>	Pump
<b>M</b>	Motor

2 Unit		
	Pump	Motor
<b>A</b>	Single unit	Standard Motor w/o checks
<b>B</b>	Multiple unit	Standard Motor w/ two checks
<b>C</b>	—	Standard Motor w/one anti cavitation check (ACC)

3 Displacement	
<b>0190</b>	19 cc/rev (1.16 in <sup>3</sup> /rev)
<b>0230</b>	23 cc/rev (1.40 in <sup>3</sup> /rev)
<b>0260</b>	26 cc/rev (1.59 in <sup>3</sup> /rev)
<b>0290</b>	29 cc/rev (1.77 in <sup>3</sup> /rev)
<b>0330</b>	33 cc/rev (2.01 in <sup>3</sup> /rev)
<b>0370</b>	37 cc/rev (2.26 in <sup>3</sup> /rev)
<b>0410</b>	41 cc/rev (2.50 in <sup>3</sup> /rev)
<b>0440</b>	44 cc/rev (2.69 in <sup>3</sup> /rev)
<b>0500</b>	50 cc/rev (3.05 in <sup>3</sup> /rev)

4 Rotation	
<b>C</b>	Clockwise
<b>A</b>	Counter clockwise
<b>B</b>	Bi-directional (Motor Only)

5 Shaft	
<b>C1</b>	SAE 19-4 spline, 11T
<b>D1</b>	SAE "B" spline, 13T
<b>E1</b>	SAE "B-B" spline, 15T
<b>M1</b>	SAE "B" parallel key
<b>M2</b>	SAE "B-B", parallel key
<b>L6</b>	SAE 19-1 parallel key
<b>R3</b>	SAE "B" taper 8:1

6 Flange	
<b>A3</b>	SAE "B" 4-bolt square
<b>A4</b>	SAE "C" 4-bolt square
<b>H2</b>	SAE "A" 2-bolt
<b>H3</b>	SAE "B" 2-bolt

7 Shaft Seal	
<b>X</b>	No seal
<b>N</b>	NBR (Buna-N) (pump only)
<b>V</b>	FPM, FKM (Fluorocarbon) (pump only)
<b>M</b>	Double NBR (Buna-N) (pump only)
<b>W</b>	Double FPM (Fluorocarbon) (pump only)
<b>H</b>	High Pres.(5bar) (motor only)

\*See Note 2

9 Motor Drain Option	
<b>B1</b>	No drain
<b>C</b>	SAE-6, straight thread o-ring

10 Motor Drain Position	
<b>4</b>	Rear drain

11 Inlet Options (Multi Section Units Only)	
<b>C</b>	Common
<b>S</b>	Separate

12 Multiple Unit	
<b>A</b>	Last section
<b>B</b>	Middle section

8 Port Options*			
Code	Description	Rear Ports	Available Displacements for Side Ports
<b>B1</b>	No ports	n/a	19 thru 50 cc
<b>D3</b>	SAE-8 straight thread o-ring	Yes	19 thru 50 cc
<b>D4</b>	SAE-10 straight thread o-ring	Yes	19 thru 50 cc
<b>D5</b>	SAE-12 straight thread o-ring	Yes	19 thru 50 cc
<b>D6</b>	SAE-16 straight thread o-ring	Yes	19 thru 50 cc
<b>D7</b>	SAE-20 straight thread o-ring	No	19 thru 50 cc
<b>D8</b>	SAE-24 straight thread o-ring	No	29 thru 50 cc
<b>S1</b>	½" Split Flange, SAE Code 61	No	19 thru 50 cc
<b>S2</b>	¾" Split Flange, SAE Code 61	No	19 thru 50 cc
<b>S3</b>	1" Split Flange, SAE Code 61	No	19 thru 50 cc
<b>S4</b>	1¼" Split Flange, SAE Code 61	No	19 thru 50 cc
<b>S5</b>	1½" Split Flange, SAE Code 61	No	29 thru 50 cc
<b>S6</b>	2" Split Flange, SAE Code 61	No	29 thru 50 cc

\*See Note 3

**Notes:**

1. See shaft load capacity table, page 14, to check shaft strength.
2. Specify "V" or "W" code if phosphate ester fluid is used or if operating temperatures exceed 80°C (176°F).
3. See page 16 for recommended maximum flows.



**PGP/PGM 620 Specification - Standard Displacements - Single Unit**

Pump	Code	0190	0230	0260	0290	0330	0370	0410	0440	0500
	Displacement	cc/rev	19.0	23.0	26.0	29.0	33.0	37.0	41.0	44.0
in <sup>3</sup> /rev		1.16	1.40	1.59	1.77	2.01	2.26	2.50	2.68	3.05
Continuous Pressure	bar	275	275	275	275	275	250	220	210	210
Intermittent Pressure	psi	3989	3989	3989	3989	3989	3626	3191	3046	3046
Port Location "X"	mm	82.5	86.9	90.2	93.5	97.9	102.3	106.7	110.0	116.6
	inch	3.25	3.42	3.55	3.68	3.85	4.03	4.20	4.33	4.59
Overall Length "Y"	mm	123.5	127.9	131.2	134.5	138.9	143.3	147.7	151.0	157.6
	inch	4.86	5.04	5.17	5.30	5.47	5.64	5.81	5.94	6.20
*Weight	kg	12.1	12.2	12.3	12.6	12.7	12.9	13.0	13.1	13.3
	lb	26.7	26.9	27.1	27.8	28.0	28.4	28.7	28.9	29.3

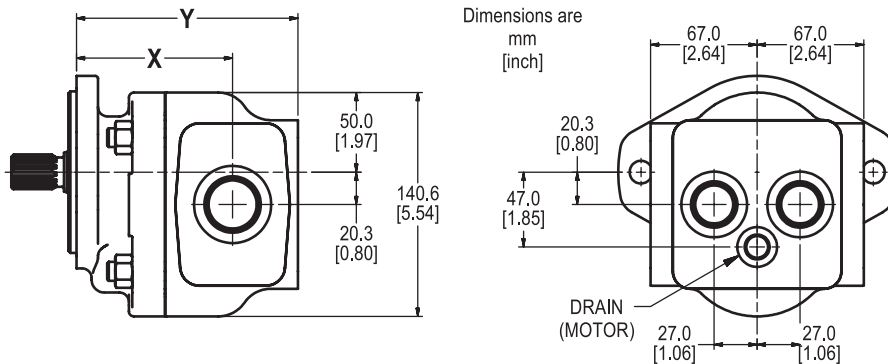

**PGP/PGM 620 Specification - Standard Displacements - Tandem Unit**

Pump	Code	0190	0230	0260	0290	0330	0370	0410	0440	0500
	Displacement	cc/rev	19.0	23.0	26.0	29.0	33.0	37.0	41.0	44.0
in <sup>3</sup> /rev		1.16	1.40	1.59	1.77	2.01	2.26	2.50	2.68	3.05
Front Port Location "X"	mm	82.5	86.9	90.2	93.5	97.9	102.3	106.7	110.0	116.6
Front Overall Length "Y"	inch	3.25	3.42	3.55	3.68	3.85	4.03	4.20	4.33	4.59
Front Overall Length "Y"	mm	123.5	127.9	131.2	134.5	138.9	143.3	147.7	151.0	157.6
Rear Overall Length "Y"	inch	4.86	5.04	5.17	5.30	5.47	5.64	5.81	5.94	6.20
Rear Overall Length "Y"	mm	123.5	127.9	131.2	134.5	138.9	143.3	147.7	146.0	157.6
*Weight Front Section	kg	12.1	12.2	12.3	12.6	12.7	12.9	13.0	13.1	13.3
	lb	26.7	26.9	27.1	27.8	28.0	28.4	28.7	28.9	29.3
*Weight Rear Section	kg	12.1	12.2	12.3	12.6	12.7	12.9	13.0	11.5	13.3
	lb	26.7	26.9	27.1	27.8	28.0	28.4	28.7	25.4	29.3

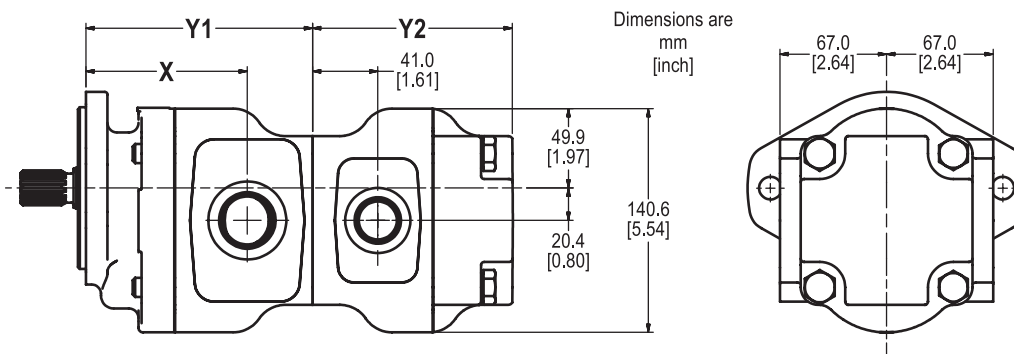

\*All weights are approximate. The actual weight of an assembly will depend upon the porting and the type of shaft and mounting specified. The weight of a tandem pump will be the sum of the weights of each section.

**PGP/PGM 640 How to Specify**

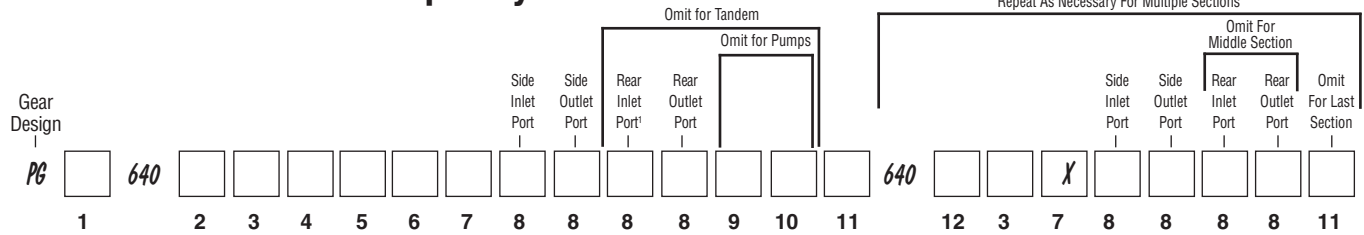

1 Pump/Motor	
P	Pump
M	Motor

4 Rotation	
C	Clockwise
A	Counter clockwise
B	Bi-directional (Motor Only)

7 Shaft Seal	
X	No seal
N	NBR (Buna-N) (pump only)
V	FPM, FKM (Fluorocarbon) (pump only)
M	Double NBR (Buna-N) (pump only)
W	Double FPM (Fluorocarbon) (pump only)
H	High Pres. (5bar) (motor only)

9 Motor Drain Option	
B1	No drain
C	SAE-6, Straight thread o-ring

2 Unit		
	Pump	Motor
A	Single unit	Standard Motor w/o checks
B	Multiple unit	Standard Motor w/ two checks
C	—	Standard Motor w/one anti cavitation check (ACC)

5 Shaft	
D1	SAE "B" spline, 13T
E1	SAE "B-B" spline, 15T
E4	SAE "C" spline, 14T
M2	SAE "B-B" parallel key
N1	SAE "C" parallel key

10 Motor Drain Position	
4	Rear drain

11 Inlet Options (Multi Section Units Only)	
C	Common inlet (passage)
S	Separate

3 Displacement	
0300	30 cc/rev (1.83 in <sup>3</sup> /rev)
0350	37 cc/rev (2.14 in <sup>3</sup> /rev)
0450	45 cc/rev (2.75 in <sup>3</sup> /rev)
0550	55 cc/rev (3.36 in <sup>3</sup> /rev)
0650	65 cc/rev (4.00 in <sup>3</sup> /rev)
0750	75 cc/rev (4.58 in <sup>3</sup> /rev)
0800	80 cc/rev (4.88 in <sup>3</sup> /rev)

6 Flange	
A3	SAE "B" 4-bolt square
A4	SAE "C" 4-bolt square
H3	SAE "B" 2-bolt flange
K3	SAE "C" 2-bolt flange

12 Multiple Unit	
A	Last section
B	Middle section

8 Port Options*			
Code	Description	Rear Ports	Available Displacements for Side Ports
B1	No ports	n/a	30 thru 80 cc
D5	SAE-12 straight thread o-ring	Yes	30 thru 80 cc
D6	SAE-16 straight thread o-ring	Yes	30 thru 80 cc
D7	SAE-20 straight thread o-ring	Yes	30 thru 80 cc
D8	SAE-24 straight thread o-ring	Yes	30 thru 80 cc
D9	SAE-32 straight thread o-ring	No	30 thru 80 cc
S2	¾" Split Flange, SAE Code 61	No	30 thru 80 cc
S3	1" Split Flange, SAE Code 61	No	30 thru 80 cc
S4	1¼" Split Flange, SAE Code 61	No	30 thru 80 cc
S5	1½" Split Flange, SAE Code 61	No	30 thru 80 cc
S6	2" Split Flange, SAE Code 61	No	40 thru 80 cc

\*See Note 3

**Notes:**

1. See shaft load capacity table, page 14, to check shaft strength.
2. Specify "V" or "W" code if phosphate ester fluid is used or if operating temperatures exceed 80°C (176°F).
3. See page 16 for recommended maximum flows.

**PGP/PGM 640 Specification - Standard Displacements - Single Unit**

Pump Displacement	Code	0300	0350	0450	0550	0650	0750	0800
	cc/rev	30.0	35.0	45.0	55.0	65.0	75.0	80.0
	in <sup>3</sup> /rev	1.83	2.14	2.75	3.36	3.97	4.58	4.88
Continuous Pressure	bar	275	275	275	275	275	235	215
	psi	3989	3989	3989	3989	3989	3408	3118
Intermittent Pressure	bar	300	300	300	300	300	260	240
	psi	4351	4351	4351	4351	4351	3771	3481
Port Location "X"	mm	128.6	128.6	131.8	135.6	138.4	142.2	142.2
	inch	5.07	5.07	5.19	5.34	5.45	5.60	5.60
Overall Length "Y"	mm	176	176	183	189	196	203	203
	inch	6.90	6.93	7.19	7.45	7.71	7.99	7.99
*Weight	kg	20.6	20.6	21.2	22.0	22.6	23.3	24.0
	lb	42.2	45.4	46.7	48.5	49.8	51.4	53.0

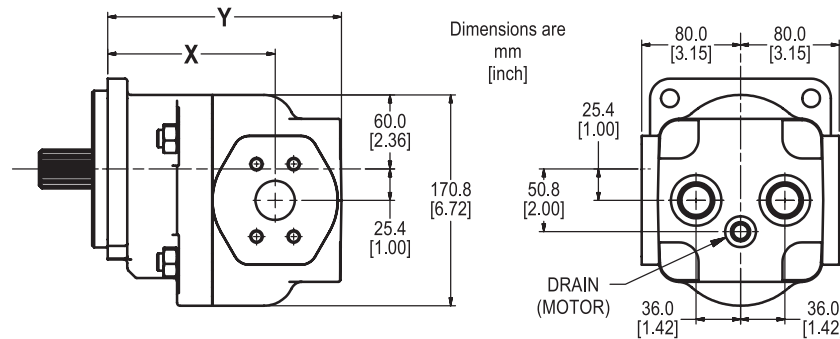

**PGP/PGM 640 Specification - Standard Displacements - Tandem Unit**

Pump Displacement	Code	0300	0350	0450	0550	0650	0750	0800
	cc/rev	30.0	35.0	45.0	55.0	65.0	75.0	80.0
	in <sup>3</sup> /rev	1.83	2.14	2.75	3.36	3.97	4.58	4.88
Front Port Location "X1"	mm	128.6	128.6	131.8	135.6	138.4	142.2	142.2
	inch	5.06	5.06	5.19	5.34	5.45	5.60	5.60
Rear Port Location "X2"	mm	44.5	44.5	47.9	50.7	54.5	58.0	58.0
	inch	1.75	1.75	1.89	2.00	2.15	2.28	2.28
Front Overall Length "Y"	mm	173.1	173.1	179.7	186.3	192.9	200.2	200.2
	inch	6.81	6.81	7.07	7.33	7.59	7.88	7.88
Rear Overall Length "Y"	mm	150.9	150.9	157.5	164.1	170.7	178.0	178.0
	inch	5.94	5.94	6.20	6.46	6.72	7.01	7.01
*Weight Front Section	kg	20.3	20.3	20.9	21.7	22.3	23.0	23.0
	lb	44.8	44.8	46.1	47.8	49.2	50.7	50.7
*Weight Rear Section	kg	19.3	19.3	19.9	20.7	21.3	22.0	22.0
	lb	42.5	42.5	43.9	45.6	47.0	48.5	48.5

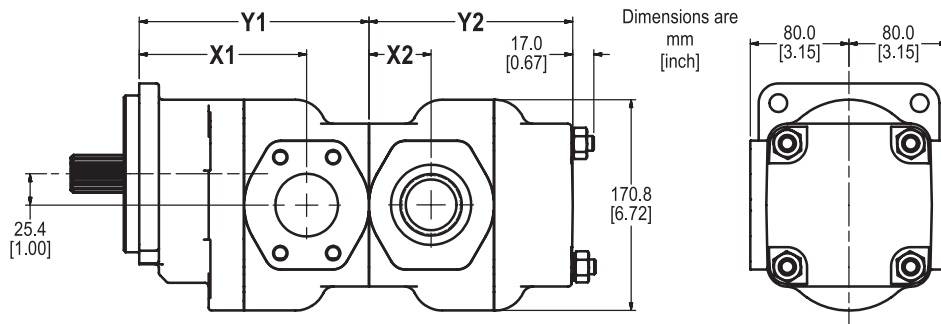

\*All weights are approximate. The actual weight of an assembly will depend upon the porting and the type of shaft and mounting specified. The weight of a tandem pump will be the sum of the weights of each section.

**PGP/PGM 600 Spline Shaft**

Dimensions are shown as  $\frac{\text{mm}}{[\text{in}]}$

**Code A1 (610 only)**

9T, 16/32 PITCH, 32L S.A.E. "A" SPLINE  
 FLAT ROOT SIDE FIT

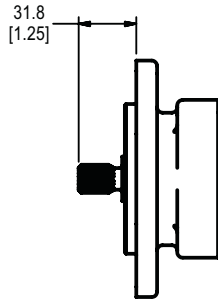

**Code E1 (620 & 640 only)**

15T, 16/32 PITCH, 46L S.A.E. "B-B" SPLINE  
 FLAT ROOT SIDE FIT

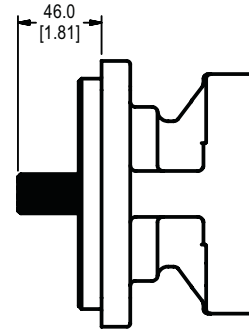

**Code C1 (610 & 620 only)**

11T, 16/32 PITCH, 38.1L S.A.E. "19-4" SPLINE  
 FLAT ROOT SIDE FIT

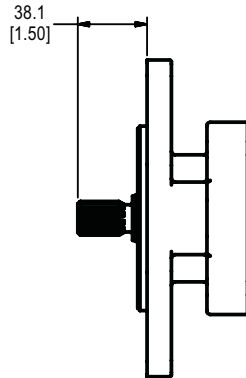

**Code E4 (640 only)**

14T, 12/24 PITCH, 55.6L S.A.E. "C" SPLINE  
 FLAT ROOT SIDE FIT

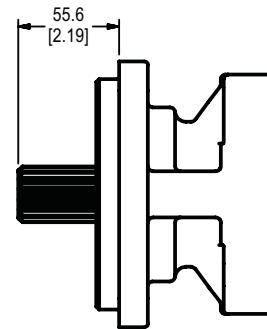

**Code D1 (610, 620 & 640)**

13T, 16/32 PITCH, 41.2L S.A.E. "B" SPLINE  
 FLAT ROOT SIDE FIT

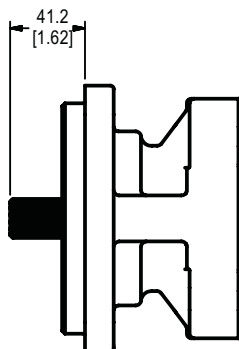

**PGP/PGM 600 Drive Shaft**

**Code K1 (610 only)**  
 Ø15.88, 4.0 KEY,  
 NO THREAD, 32L  
 S.A.E. "A" PARALLEL

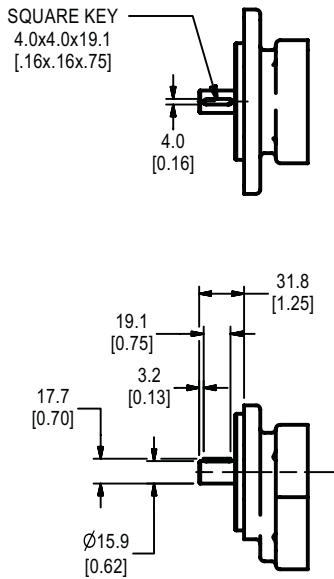

**Code M1**  
**(620 only)**  
 Ø22.22, 6.3 KEY,  
 NO THREAD, 41.2L  
 S.A.E. "B" PARALLEL

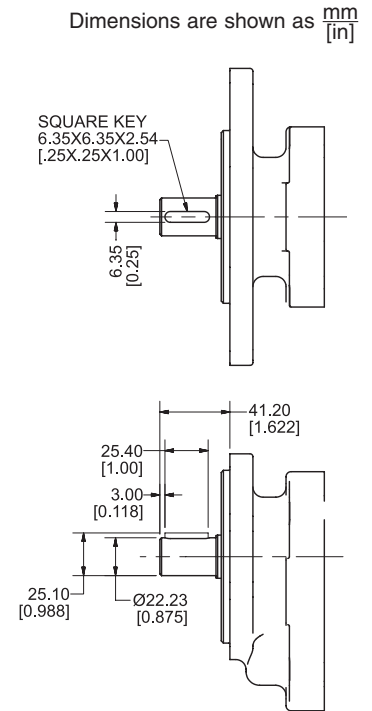

**Code L6**  
**(610 & 620 only)**  
 Ø19.05, 4.8 KEY,  
 NO THREAD, 32L  
 S.A.E. "19-1" PARALLEL

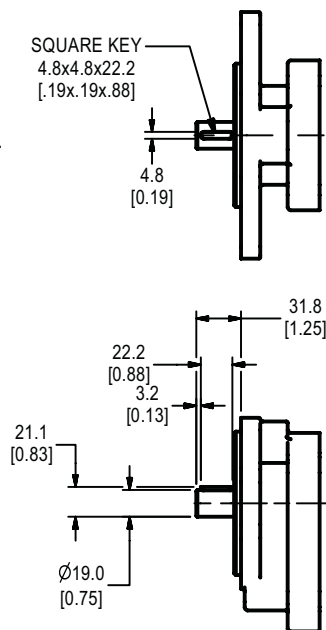

**Code M2**  
**(620 & 640 only)**  
 Ø25.4, 6.3 KEY,  
 NO THREAD, 46L  
 S.A.E. "B-B" PARALLEL

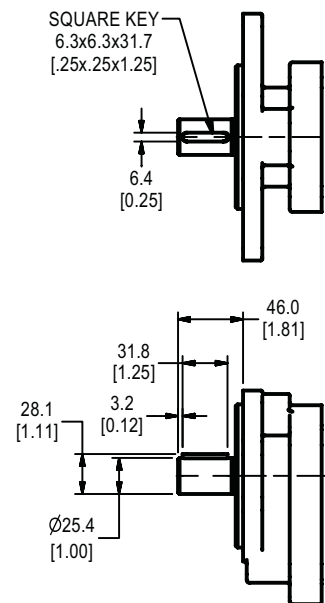

**PGP/PGM 600 Drive Shaft**

Dimensions are shown as  $\frac{mm}{[in]}$

**Code N1  
 (640 only)**  
 Ø31.7, 8.0 KEY,  
 NO THREAD, 55.6L  
 S.A.E. "C" PARALLEL

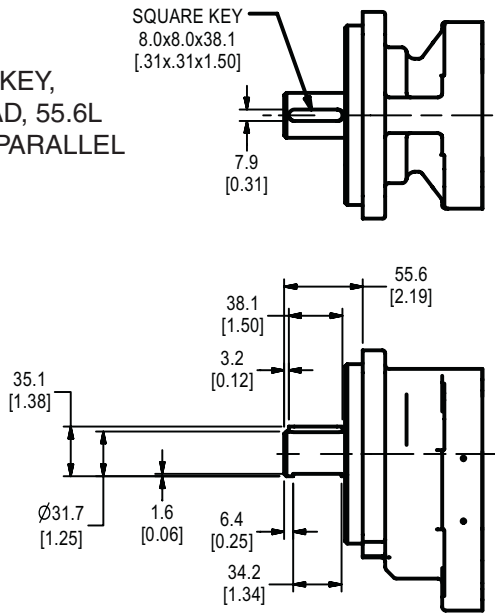

**Code R3 (620 only)**  
 SAE "B" TAPER w/Key

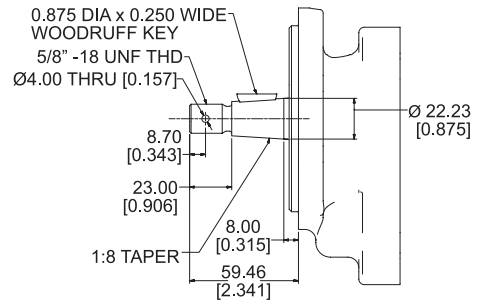

**PGP/PGM 600- Shaft Load Capacity - Continuous Rating**

Code	Type	Shaft Description	Maximum Allowable Torque					
			PGP610		PGP620		PGP640	
			Nm	lb-ft	Nm	lb-ft	Nm	lb-ft
A1	spline	SAE A, 9 tooth, 16/32 pitch	85	62	N/A	N/A	N/A	N/A
C1	spline	SAE 19-4, 11 tooth, 16/32 pitch	125	92	125	92	N/A	N/A
D1	spline	SAE B, 13 tooth, 16/32 pitch	245	181	245	181	350	258
E1	spline	SAE B-B, 15 tooth, 16/32 pitch	N/A	N/A	390	288	535	395
E4	spline	SAE C, 14 tooth, 12/24 pitch	N/A	N/A	N/A	N/A	1040	767
n/a	spline	Connecting Shaft-Tandem Units	130	96	225	166	435	321
K1	key	SAE A, 0.625" dia, 0.156" key	85	63	N/A	N/A	N/A	N/A
L6	key	SAE 19-1, 0.750" dia, 0.188" key	170	125	170	125	N/A	N/A
M1	key	SAE B, 0.875" dia, 0.250" key	200	148	200	148	N/A	N/A
M2	key	SAE BB, 1.000" dia, 0.250" key	N/A	N/A	320	236	320	236
N1	key	SAE C, 1.250" dia, 0.312" key	N/A	N/A	N/A	N/A	630	465
R3	taper	SAE B, 1:8 taper, 5/8" - 18 thd	N/A	N/A	190	140	N/A	N/A

To calculate the theoretical torque of a pump or motor:

$$\text{Torque (Nm)} = \frac{\text{Pressure (bar)} \times \text{Displacement (cc/rev)}}{62.8}$$

$$\text{Torque (lb-ft)} = \frac{\text{Pressure (psi)} \times \text{Displacement (cuin/rev)}}{75.4}$$

Approximate actual torque to drive a pump = 1.1 x theoretical torque.

Approximate actual torque from a motor = .9 x theoretical torque.

The total shaft torque for a multiple section unit will be the sum of the values for each section.  
 Each connecting shaft should also be checked for torque load capacity.

**PGP/PGM 600 Mounting Flange**

Dimensions are shown as  $\frac{\text{mm}}{\text{in}}$

**Code H2 (610 & 620 only)**  
 S.A.E. "A" 2-BOLT

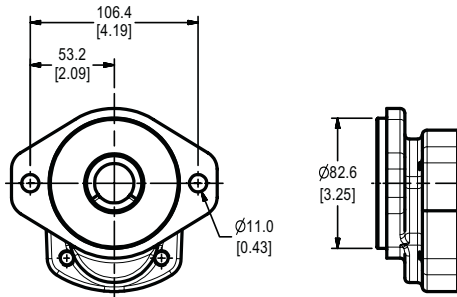

**Code A3 (620 & 640 only)**  
 S.A.E. "B" 4-BOLT

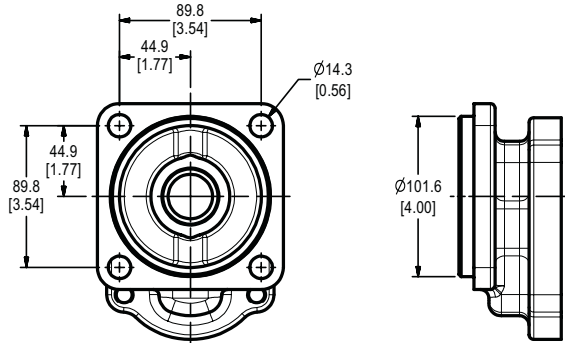

**Code H3 (610, 620 & 640)**  
 S.A.E. "B" 2-BOLT

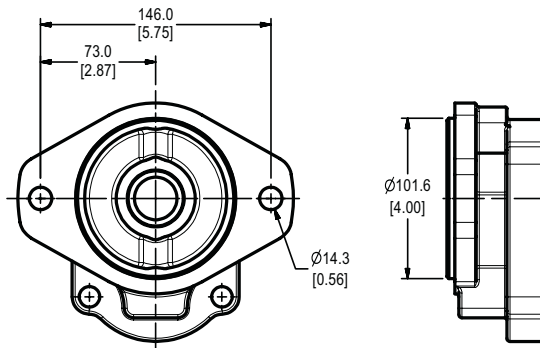

**Code A4 (620 & 640 only)**  
 S.A.E. "C" 4-BOLT

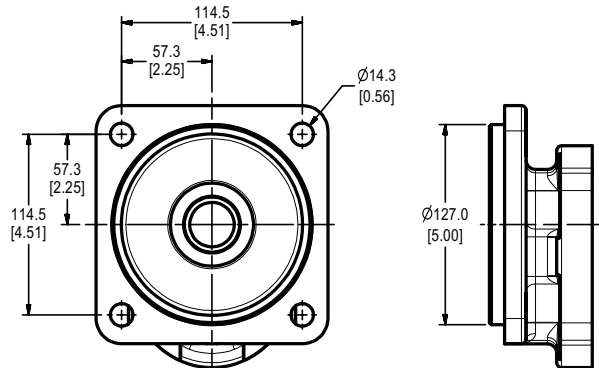

**Code K3 (640 only)**  
 S.A.E. "C" 2-BOLT

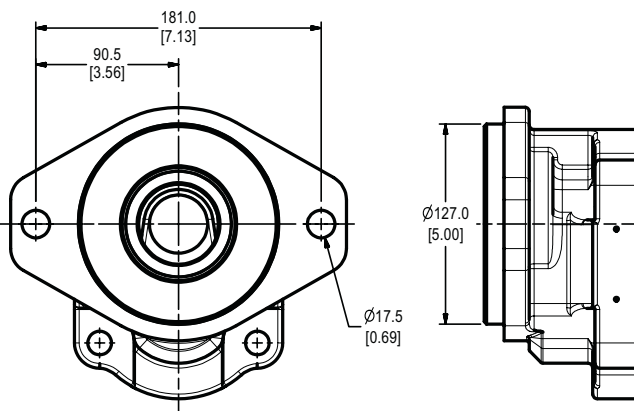

**PGP/PGM 600 Porting**

Dimensions are shown as  $\frac{mm}{[in]}$

**Porting Code D**

SAE J1926 STRAIGHT THREAD O-RING

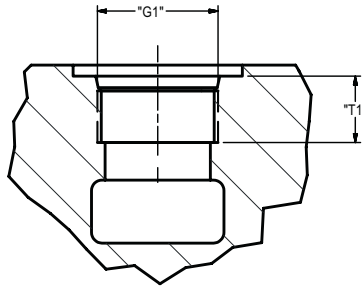

\*Note: The pump inlet flow velocity should not exceed 3.0 m/s (10 fps). Pump outlet and motor inlet or outlet flow velocities should not exceed 6.1 m/s (20 fps).

Code	Dash Size	Nominal Tube OD	"G1" Thd Size inch	"T1" Full Thd Min mm (inch)	Recommended Max Flow* lpm (gpm)	
					Pump Inlet	Pump Outlet & Motor
D3	-8	1/2"	3/4"-16	14.3 (.56)	14 (3.8)	28 (7.5)
D4	-10	5/8"	7/8"-14	16.7 (.66)	22 (5.7)	44 (11.5)
D5	-12	3/4"	1-1/16"-12	19.0 (.75)	34 (9.1)	69 (18.2)
D6	-16	1"	1-5/16"-12	19.0 (.75)	66 (17.4)	132 (34.9)
D7	-20	1 1/4"	1-5/8"-12	19.0 (.75)	108 (28.5)	215 (56.9)
D8	-24	1 1/2"	1-7/8"-12	19.0 (.75)	160 (42.2)	319 (84.3)
D9	-32	2"	2-1/2"-12	19.0 (.75)	294 (77.7)	588 (155.3)

**Porting Code S**

FOUR BOLT SPLIT FLANGE TYP SAE J518 CODE 61

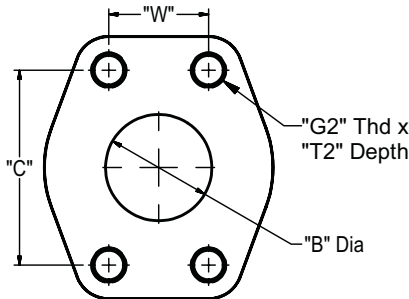

\*Note: The pump inlet flow velocity should not exceed 3.0 m/s (10 fps). Pump outlet and motor inlet or outlet flow velocities should not exceed 6.1 m/s (20 fps).

Code	Dash Size	Nominal ID	"G2" Thd Size inch	"T2" Full Thd Min mm (inch)	"B" Dia mm (inch)	"C" mm (inch)	"W" mm (inch)	Recommended Max Flow* lpm (gpm)	
								Pump Inlet	Pump Outlet & Motor
S1	-8	1/2"	5/16"-18	15.0 (0.59)	12.7 (0.50)	38.10 (1.500)	17.48 (0.688)	23 (6.1)	46 (12.2)
S2	-12	3/4"	3/8"-16	14.0 (0.56)	19.0 (0.75)	47.63 (1.875)	22.23 (0.875)	52 (13.8)	104 (27.5)
S3	-16	1"	3/8"-16	20.6 (0.81)	25.4 (1.00)	52.37 (2.062)	26.19 (1.031)	93 (24.5)	185 (49.0)
S4	-20	1 1/4"	7/16"-14	20.6 (0.81)	31.8 (1.25)	58.72 (2.312)	30.17 (1.188)	145 (38.3)	290 (76.5)
S5	-24	1 1/2"	1/2"-13	27.0 (1.06)	38.1 (1.50)	69.85 (2.750)	35.71 (1.406)	208 (55.1)	417 (110.2)
S6	-32	2"	1/2"-13	27.0 (1.06)	50.8 (2.00)	77.77 (3.062)	42.88 (1.688)	370 (97.9)	742 (195.9)



<b>PGP610 Typical Outlet Flow and Input Power</b>											
<b>120°F (50°C), ISO VG32 Fluid</b>											
<b>Speed rpm</b>	<b>units</b>	<b>Displacement / Maximum Allowable Continuous Pressure</b>									
	<b>cc in<sup>3</sup> bar psi</b>	<b>7</b>	<b>10</b>	<b>14</b>	<b>16</b>	<b>18</b>	<b>21</b>	<b>23</b>	<b>26</b>	<b>28</b>	<b>32</b>
<b>900</b>	<b>lpm</b>	6.0	8.5	11.9	13.6	15.3	17.9	19.6	22.1	23.8	27.2
	<b>gpm</b>	1.6	2.2	3.1	3.6	4.0	4.7	5.2	5.8	6.3	7.2
	<b>kw</b>	3.1	4.4	6.2	7.1	7.4	7.8	7.8	7.8	7.7	9.0
	<b>hp</b>	4.2	5.9	8.3	9.5	9.9	10.4	10.4	10.4	10.3	12.1
<b>1200</b>	<b>lpm</b>	8.0	11.3	15.9	18.1	20.4	23.8	26.1	29.5	31.8	36.3
	<b>gpm</b>	2.1	3.0	4.2	4.8	5.4	6.3	6.9	7.8	8.4	9.6
	<b>kw</b>	4.1	5.9	8.3	9.5	9.9	10.4	10.4	10.3	10.2	12.0
	<b>hp</b>	5.6	7.9	11.1	12.7	13.2	13.9	13.9	13.9	13.7	16.1
<b>1500</b>	<b>lpm</b>	10.0	14.3	20.1	22.9	25.8	30.1	32.9	37.2	40.1	45.8
	<b>gpm</b>	2.6	3.8	5.3	6.1	6.8	7.9	8.7	9.8	10.6	12.1
	<b>kw</b>	5.2	7.5	10.5	12.0	12.5	13.1	13.1	13.1	12.9	15.2
	<b>hp</b>	7.0	10.0	14.0	16.0	16.7	17.6	17.6	17.5	17.3	20.4
<b>1800</b>	<b>lpm</b>	12.1	17.3	24.2	27.6	31.1	36.3	39.7	44.9	48.4	55.3
	<b>gpm</b>	3.2	4.6	6.4	7.3	8.2	9.6	10.5	11.9	12.8	14.6
	<b>kw</b>	6.3	9.0	12.6	14.3	15.0	15.8	15.8	15.7	15.5	18.3
	<b>hp</b>	8.4	12.0	16.8	19.2	20.1	21.1	21.1	21.0	20.8	24.5
<b>2100</b>	<b>lpm</b>	14.2	20.3	28.4	32.4	36.5	42.6	46.6	52.7	56.7	64.8
	<b>gpm</b>	3.7	5.4	7.5	8.6	9.6	11.2	12.3	13.9	15.0	17.1
	<b>kw</b>	7.4	10.6	14.8	16.9	17.7	18.6	18.6	18.5	18.3	21.5
	<b>hp</b>	9.9	14.2	19.9	22.7	23.7	24.9	24.9	24.8	24.6	28.9
<b>2400</b>	<b>lpm</b>	16.3	23.3	32.6	37.2	41.9	48.9	53.5	60.5	65.2	74.5
	<b>gpm</b>	4.3	6.1	8.6	9.8	11.1	12.9	14.1	16.0	17.2	19.7
	<b>kw</b>	8.6	12.2	17.1	19.6	20.4	21.5	21.5	21.4	21.2	24.9
	<b>hp</b>	11.5	16.4	22.9	26.2	27.4	28.8	28.8	28.7	28.42	33.4
<b>2700</b>	<b>lpm</b>	18.3	26.2	36.7	41.9	47.1	55.0	60.2	68.1	73.3	83.8
	<b>gpm</b>	4.8	6.9	9.7	11.1	12.5	14.5	15.9	18.0	19.4	22.1
	<b>kw</b>	9.7	13.9	19.5	22.2	23.2	24.4	24.4	24.3	24.1	28.3
	<b>hp</b>	13.1	18.6	26.1	29.8	31.1	32.7	32.7	32.6	32.3	38.0
<b>3000</b>	<b>lpm</b>	20.4	29.1	40.7	46.6	52.4	61.1	66.9	75.7	81.5	93.1
	<b>gpm</b>	5.4	7.7	10.8	12.3	13.8	16.1	17.7	20.0	21.5	24.6
	<b>kw</b>	10.9	15.6	21.9	25.0	26.1	27.4	27.4	27.3	27.0	31.8
	<b>hp</b>	14.7	21.0	29.3	33.5	35.0	36.8	36.8	36.6	36.3	42.7
<b>3300</b>	<b>lpm</b>	22.3	31.8	44.6	51.0	57.3	66.9	73.2	82.8	89.2	101.9
	<b>gpm</b>	5.9	8.4	11.8	13.5	15.1	17.7	19.3	21.9	23.6	26.9
	<b>kw</b>	12.2	17.4	24.3	27.8	29.0	30.5	30.5	30.4	30.1	35.4
	<b>hp</b>	16.3	23.3	32.6	37.3	38.9	40.9	40.9	40.8	40.4	47.5

<b>PGP620 Typical Outlet Flow and Input Power 120°F (50°C), ISO VG32 Fluid</b>										
Speed rpm	units	Displacement / Maximum Allowable Continuous Pressure								
	cc in <sup>3</sup> bar psi	19	23	26	29	33	37	41	44	50
900	lpm	16.2	19.6	22.1	24.7	28.1	31.5	34.9	37.4	42.5
	gpm	4.3	5.2	5.8	6.5	7.4	8.3	9.2	9.9	11.2
	kw	8.4	10.2	11.5	12.9	14.6	14.9	14.5	14.9	16.9
	hp	11.3	13.7	15.5	17.2	19.6	20.0	19.5	20.0	22.7
1200	lpm	21.7	26.1	29.5	32.9	37.4	42.0	46.5	49.9	56.7
	gpm	5.7	6.9	7.8	8.7	9.9	11.1	12.3	13.2	15.0
	kw	11.2	13.6	15.4	17.2	19.5	19.9	19.4	19.9	22.6
	hp	15.1	18.2	20.6	23.0	26.2	26.7	26.0	26.6	30.3
1500	lpm	27.2	32.9	37.2	41.5	47.3	53.0	58.7	63.0	71.6
	gpm	7.2	8.7	9.8	11.0	12.5	14.0	15.5	16.7	18.9
	kw	14.2	17.2	19.4	21.7	24.7	25.1	24.5	25.1	28.5
	hp	19.0	23.0	26.1	29.1	33.1	33.7	32.9	33.7	38.3
1800	lpm	32.8	39.7	44.9	50.1	57.0	63.9	70.8	76.0	86.4
	gpm	8.7	10.5	11.9	13.2	15.1	16.9	18.7	20.1	22.8
	kw	17.0	20.6	23.3	26.0	29.6	30.2	29.4	30.1	34.2
	hp	22.8	27.7	31.3	34.9	39.7	40.4	39.4	40.4	45.9
2100	lpm	38.5	46.6	52.7	58.8	66.9	75.0	83.1	89.2	101.3
	gpm	10.2	12.3	13.9	15.5	17.7	19.8	21.9	23.6	26.8
	kw	20.1	24.3	27.5	30.7	34.9	35.6	34.7	35.5	40.4
	hp	26.9	32.6	36.9	41.1	46.8	47.7	46.5	47.7	54.2
2400	lpm	44.2	53.5	60.5	67.5	76.8	86.1	95.4	102.4	116.4
	gpm	11.7	14.1	16.0	17.8	20.3	22.8	25.2	27.1	30.7
	kw	23.2	28.1	31.8	35.4	40.3	41.1	40.1	41.1	46.7
	hp	31.1	37.7	42.6	47.5	54.1	55.1	53.8	55.1	62.6
2700	lpm	49.8	60.2	68.1	76.0	86.4	96.9	107.4	115.2	131.0
	gpm	13.1	15.9	18.0	20.1	22.8	25.6	28.4	30.4	34.6
	kw	26.4	32.0	36.2	40.3	45.9	46.8	45.6	46.7	53.1
	hp	35.4	42.9	48.5	54.1	61.5	62.7	61.2	62.7	71.2
3000	lpm	55.3	66.9	75.7	84.4	96.0	107.7	119.3	128.0	145.5
	gpm	14.6	17.7	20.0	22.3	25.4	28.4	31.5	33.8	38.4
	kw	29.7	35.9	40.6	45.3	51.6	52.6	51.3	52.5	59.7
	hp	39.8	48.2	54.5	60.8	69.1	70.5	68.7	70.4	80.0

PGP640 Typical Outlet Flow and Input Power 120°F (50°C), ISO VG32 Fluid								
Speed rpm	units	Displacement / Maximum Allowable Continuous Pressure						
	cc in <sup>3</sup> bar psi	30	35	45	55	65	75	80
900	lpm	25.5	31.5	38.3	46.8	55.3	63.8	68.0
	gpm	6.7	8.3	10.1	12.4	14.6	16.9	18.0
	kw	13.3	16.4	20.0	24.4	27.8	27.2	27.1
	hp	17.8	22.0	26.8	32.7	37.3	36.5	36.3
1200	lpm	34.2	42.0	51.0	62.4	73.7	85.1	90.7
	gpm	9.0	11.1	13.5	16.5	19.5	22.5	24.0
	kw	17.7	21.9	26.6	32.5	37.0	36.3	36.1
	hp	23.8	29.3	35.7	43.6	49.7	48.7	48.4
1500	lpm	43.0	53.0	64.5	78.8	93.1	107.4	114.6
	gpm	11.4	14.0	17.0	20.8	24.6	28.4	30.3
	kw	22.4	27.6	33.6	41.1	46.8	45.9	45.7
	hp	30.1	37.1	45.1	55.1	62.8	61.5	61.2
1800	lpm	51.8	63.9	77.8	95.0	112.3	129.6	138.2
	gpm	13.7	16.9	20.5	25.1	29.7	34.2	36.5
	kw	26.9	33.2	40.4	49.3	56.2	55.0	54.8
	hp	36.1	44.5	54.1	66.1	75.3	73.8	73.5
2100	lpm	60.8	75.0	91.2	111.5	131.7	152.0	162.1
	gpm	16.1	19.8	24.1	29.4	34.8	40.2	42.8
	kw	31.7	39.1	47.6	58.2	66.3	64.9	64.6
	hp	42.6	52.5	63.8	78.0	88.8	87.0	86.7
2400	lpm	69.8	86.1	104.8	128.0	151.3	174.6	186.2
	gpm	18.4	22.8	27.7	33.8	40.0	46.1	49.2
	kw	36.7	45.2	55.0	67.2	76.6	75.0	74.7
	hp	49.2	60.6	73.8	90.1	102.7	100.6	100.1
2700	lpm	78.6	96.9	117.9	144.0	170.2	196.4	209.5
	gpm	20.8	25.6	31.1	38.1	45.0	51.9	55.3
	kw	41.7	51.4	62.6	76.5	87.1	85.3	84.9
	hp	55.9	69.0	83.9	102.6	116.8	114.4	113.9
3000	lpm	87.3	107.7	131.0	160.1	189.2	218.3	232.8
	gpm	23.1	28.4	34.6	42.3	50.0	57.7	61.5
	kw	46.9	57.8	70.3	85.9	97.9	95.9	95.5
	hp	62.9	77.5	94.3	115.2	131.2	128.6	128.0

## GEAR PUMP FLUID RECOMMENDATIONS

### PETROLEUM OILS (Mineral-based)

#### Viscosity Recommendations

Optimum operating viscosity is considered to be about 20 cSt (100 SUS).

Minimum: approximately 7.5 - 10 cSt (50 - 60 SUS)

Maximum at start up: approximately 1600 cSt (7500 SUS)

#### Recommended Viscosity Grades

Grade	Viscosity at 40°C (100°F)	Viscosity at 100°C (210°F)
SAE 10	32 cSt (150 SUS)	4 cSt (41 SUS)
SAE 20	71 cSt (300 SUS)	7 cSt (51 SUS)
ISO 32	32 cSt (165 SUS)	5 cSt (44 SUS)
ISO 46	46 cSt (240 SUS)	7 cSt (49 SUS)

#### Other Desirable Properties

Viscosity Index: 90 minimum

Aniline Point: 175 minimum

#### Additives Usually Recommended

Rust and Oxidation Inhibitors

Foam Depressant

**Note:** Antiwear (AW) additives are not recommended. In some instances the presence of zinc compounds can actually be harmful to copper, bronze, or brass components used in the system. The use of AW oil is optional with our gear units.

#### General Recommendations

High quality hydraulic oils are essential for satisfactory performance and long life of any hydraulic system. Such oils are usually prepared from highly refined, turbine oil stocks with which select additives are compounded. We suggest following the manufacturer's specifications or the recommendations of a reputable oil supplier for the specific oil requirements on your machine.

A high viscosity oil will generally give better performance and longer life than a thin oil. Oil of around 20 cSt (100 SUS) viscosity will give optimum performance. Your selection should be as near to optimum as possible at operating temperature but not so heavy at start-up as to cause cavitation. Cold start-up procedures which allow the use of heavier oils should prove worthwhile by increasing pump life.

#### Inlet Vacuum

Vacuum measured at the inlet port of the pump generally should not exceed 13 cm (5 in) Hg. Higher vacuum can result

in cavitation which may severely damage the pump. A usually acceptable rule of thumb is that the inlet line flow velocity should not exceed 3.0 mps (10 fps). A long inlet line or the use of several fittings may necessitate increasing the line size. We suggest that each inlet port of a tandem pump have its own line from the reservoir. If possible, the fluid level in the reservoir should be higher than the pump inlet.

#### Operating Temperature

The optimum oil operating temperature is in the range of 50 to 60°C (120-140°F). If the oil temperature will be above 82°C (180°F) for significant periods of time, then FPM or FKM (Viton) seals should be used. The oil temperature should not exceed 93°C (200°F), even if FPM or FKM seals are used. High temperatures result in rapid oil deterioration and indicate the need for an oil cooler or a larger reservoir. The nearer to optimum temperature, the longer the service life of the oil, pump and other components.

#### Reservoir

Reservoir capacity in gallons should at least equal total pump output in GPM. When filling the reservoir, oil should pass through a 100-mesh screen. Pour only **clean oil** from **clean containers** into the reservoir. The reservoir should have a breather to allow air in or out. The filler cap and breather should be sealed to prevent moisture from entering. A hydraulic oil water content of as little as 0.1% can cause damage to hydraulic components.

#### Filtration

Good filtration assures improved service life at today's high operating pressures. System filtration is recommended that will maintain a contamination level according to ISO 4406: 20/18/15 for 140 bar (2000 psi), 19/17/14 for 210 bar (3000 psi) and 17/15/12 for 275 bar (4000 psi). The specific filter recommendation should come from your equipment manufacturer or filter supplier.

A 100 mesh screen should be used in the suction line leading to the pump. It should be of sufficient size to handle twice the pump capacity. The screen must be cleaned and checked regularly to avoid pump and system damage.

Oil and filters should be changed on a regular schedule and the system flushed in accordance with the original equipment manufacturer's recommendations. Reservoir air breather filters should be cleaned periodically.

**FILTRATION IS NOT A SUBSTITUTE FOR PRACTICING CLEANLINESS AND PROPER PREVENTIVE MAINTENANCE.**

**Cold Weather Operation**

Oils for use in cold weather should have a viscosity not exceeding 7500 SUS (1620 cSt) at the minimum start up temperature and a pour point of at least 20°F (11°C) below that temperature. Experience in cold climates has been satisfactory without using special oils or fluids. Start-up procedures must allow for a gradual warm-up and equipment should not be operated at full pressure until the oil reaches a reasonably fluid state.

**Comments On The Use Of Other Oils And Fluids.****Biodegradable Oils (Vegetable-Based)**

Oils of this type with properties similar to recommended petroleum oils may be used with the PGP600 series pumps and motors. Performance, pressure ratings, and durability are not adversely affected.

**Automatic Transmission Fluid (ATF)**

In general these oils have low viscosity and may be used only at reduced operating pressures and oil temperatures.

**Diesel Fuel, Kerosene, Coal Oil**

Although sometimes used as a dilutant for cold weather operations, their use is not recommended because they are insufficiently refined products.

**Transformer Oil**

Sometimes used for extremely cold weather operation. It is not generally recommended as it becomes too thin at normal operating temperatures. Oil to U.S. Military Spec MIL-H-5606 is in this category.

**WATER BASE FIRE RESISTANT FLUIDS**

Two types of water base fluids (WBF) may be used with our gear pumps and motors.

Both types of WBF come in various viscosity grades. Select the grade best suited to the equipment and its operation in terms of pressure, speed, temperature, duty cycle, etc. The fluid used should be recommended by the O.E.M. or a reputable fluid supplier.

**Water-in Oil (60/40) Invert Emulsions**

Invert emulsions are approved for use with PGP600 series pumps but at pressures up to 3000 psi or 500 psi below rated pressures, whichever is lower.

**Water Glycol Solutions**

Water glycol solutions of the types normally used in hydrostatic systems may be used with PGP600 series pumps. These consist of about 60% glycol and about 40% water with additives to improve lubricity and other characteristics. Pressures up to 3000 psi are approved, depending on the displacement.

**OPERATING LIMITS GENERALLY RECOMMENDED WITH VARIOUS FLUIDS**

FLUID:	MAX. OPER. TEMP.	MAX. INLET LINE VELOCITY	MAX. INLET VACUUM AT PUMP
Petroleum Oil	82°C (180°F)	3.0m/s (10fps)	13cm (5") Hg
W/O Emulsion	65°C (150°F)	1.2m/s (4fps)	0cm (0") Hg
Water Glycol Solution	65°C (150°F)	1.2m/s (4fps)	0cm (0") Hg

**Note:** These figures represent generally accepted maximums and will not prove satisfactory in all installations. For very severe duty cycles, it will likely be advantageous to design and operate the system at something less than these maximum limits.

**WBF Filtration**

Filtration that seems to give the best results consists of a 100-mesh inlet screen and a return line filter. For water base fluids, the inlet screen should be sized up three to four times the pump capacity. The return line filter should have a rating and size recommended by the fluid and filter manufacturers to achieve the recommended ISO contamination level.

**Note:** Finer filtration may be required by other components in the system.

**High Water Base Fluids (HWBF)**

The use of 95/5 emulsion is not recommended.

**Phosphate Ester**

Phosphate ester does not appear to effect pump performance or service life, but FPM or FKM (Viton) seals should be used with this fluid. Viscosity characteristics of phosphate ester fluid limit the recommended ranges of operating and ambient temperatures.

- DO NOT USE ANY TYPE OF FLUID NOT RECOMMENDED IN THIS BULLETIN WITHOUT FIRST CONSULTING OUR PRODUCT SUPPORT.
- OBTAIN YOUR FINAL FLUID RECOMMENDATION FROM YOUR FLUID SUPPLIER.

**Parker Hannifin Gearpump Division**  
**101 Canterbury Road, Kings Mountain, NC**  
**Telephone: 1-888-700-7411**

The items described in this document and other documents or descriptions provided by Parker Hannifin Corporation, its subsidiaries and its authorized distributors are hereby offered for sale at prices to be established by Parker Hannifin Corporation, its subsidiaries and its authorized distributors. This offer and its acceptance by any customer ("Buyer") shall be governed by all of the following Terms and Conditions. Buyer's order for any such items, when communicated to Parker Hannifin Corporation, its subsidiary or an authorized distributor ("Seller") verbally or in writing, shall constitute acceptance of this offer.

**1. Terms and Conditions of Sale:** All descriptions, quotations, proposals, offers, acknowledgments, acceptances and sales of Seller's products are subject to and shall be governed exclusively by the terms and conditions stated herein. Buyer's acceptance of any offer to sell is limited to these terms and conditions. Any terms or conditions in addition to, or inconsistent with those stated herein, proposed by Buyer in any acceptance of an offer by Seller, are hereby objected to. No such additional, different or inconsistent terms and conditions shall become part of the contract between Buyer and Seller unless expressly accepted in writing by Seller. Seller's acceptance of any offer to purchase by Buyer is expressly conditional upon Buyer's assent to all the terms and conditions stated herein, including any terms in addition to, or inconsistent with those contained in Buyer's offer. Acceptance of Seller's products shall in all events constitute such assent.

**2. Payment:** Payment shall be made by Buyer net 30 days from the date of delivery of the items purchased hereunder. Amounts not timely paid shall bear interest at the maximum rate permitted by law for each month or portion thereof that the Buyer is late in making payment. Any claims by Buyer for omissions or shortages in a shipment shall be waived unless Seller receives notice thereof within 30 days after Buyer's receipt of the shipment.

**3. Delivery:** Unless otherwise provided on the face hereof, delivery shall be made F.O.B. Seller's plant. Regardless of the method of delivery, however, risk of loss shall pass to Buyer upon Seller's delivery to a carrier. Any delivery dates shown are approximate only and Seller shall have no liability for any delays in delivery.

**4. Warranty:** Seller warrants that the items sold hereunder shall be free from defects in material or workmanship for a period of 18 months from date of shipment from Parker Hannifin Corporation. **THIS WARRANTY COMPRISES THE SOLE AND ENTIRE WARRANTY PERTAINING TO ITEMS PROVIDED HEREUNDER. SELLER MAKES NO OTHER WARRANTY, GUARANTEE, OR REPRESENTATION OF ANY KIND WHATSOEVER. ALL OTHER WARRANTIES, INCLUDING BUT NOT LIMITED TO, MERCHANTABILITY AND FITNESS FOR PURPOSE, WHETHER EXPRESS, IMPLIED, OR ARISING BY OPERATION OF LAW, TRADE USAGE, OR COURSE OF DEALING ARE HEREBY DISCLAIMED. NOTWITHSTANDING THE FOREGOING, THERE ARE NO WARRANTIES WHATSOEVER ON ITEMS BUILT OR ACQUIRED WHOLLY OR PARTIALLY, TO BUYER'S DESIGNS OR SPECIFICATIONS.**

**5. Limitation Of Remedy: SELLER'S LIABILITY ARISING FROM OR IN ANY WAY CONNECTED WITH THE ITEMS SOLD OR THIS CONTRACT SHALL BE LIMITED EXCLUSIVELY TO REPAIR OR REPLACEMENT OF THE ITEMS SOLD OR REFUND OF THE PURCHASE PRICE PAID BY BUYER, AT SELLER'S SOLE OPTION. IN NO EVENT SHALL SELLER BE LIABLE FOR ANY INCIDENTAL, CONSEQUENTIAL OR SPECIAL DAMAGES OF ANY KIND OR NATURE WHATSOEVER, INCLUDING BUT NOT LIMITED TO LOST PROFITS ARISING FROM OR IN ANY WAY CONNECTED WITH THIS AGREEMENT OR ITEMS SOLD HEREUNDER, WHETHER ALLEGED TO ARISE FROM BREACH OF CONTRACT, EXPRESS OR IMPLIED WARRANTY, OR IN TORT, INCLUDING WITHOUT LIMITATION, NEGLIGENCE, FAILURE TO WARN OR STRICT LIABILITY.**

**6. Changes, Reschedules and Cancellations:** Buyer may request to modify the designs or specifications for the items sold hereunder as well as the quantities and delivery dates thereof, or may request to cancel all or part of this order, however, no such requested modification or cancellation shall become part of the contract between Buyer and Seller unless accepted by Seller in a written amendment to this Agreement. Acceptance of any such requested modification or cancellation shall be at Seller's discretion, and shall be upon such terms and conditions as Seller may require.

**7. Special Tooling:** A tooling charge may be imposed for any special tooling, including without limitation, dies, fixtures, molds and patterns, acquired to manufacture items sold pursuant to this contract. Such special tooling shall be and remain Seller's property notwithstanding payment of any charges by Buyer. In no event will Buyer acquire any interest in apparatus belonging to Seller which is utilized in the notwithstanding any charges paid by Buyer. Unless otherwise agreed, Seller shall have the right to alter, discard or otherwise dispose of any special tooling or other property in its sole discretion at any time.

**8. Buyer's Property:** Any designs, tools, patterns, materials, drawings,

confidential information or equipment furnished by Buyer or any other items which become Buyer's property, may be considered obsolete and may be destroyed by Seller after two (2) consecutive years have elapsed without Buyer placing an order for the items which are manufactured using such property. Seller shall not be responsible for any loss or damage to such property while it is in Seller's possession or control.

**9. Taxes:** Unless otherwise indicated on the face hereof, all prices and charges are exclusive of excise, sales, use, property, occupational or like taxes which may be imposed by any taxing authority upon the manufacture, sale or delivery of the items sold hereunder. If any such taxes must be paid by Seller or if Seller is liable for the collection of such tax, the amount thereof shall be in addition to the amounts for the items sold. Buyer agrees to pay all such taxes or to reimburse Seller therefore upon receipt of its invoice. If Buyer claims exemption from any sales, use or other tax imposed by any taxing authority, Buyer shall save Seller harmless from and against any such tax, together with any interest or penalties thereon which may be assessed if the items are held to be taxable.

**10. Indemnity For Infringement of Intellectual Property Rights:** Seller shall have no liability for infringement of any patents, trademarks, copyrights, trade dress, trade secrets or similar rights except as provided in this Part 10. Seller will defend and indemnify Buyer against allegations of infringement of U.S. Patents, U.S. Trademarks, copyrights, trade dress and trade secrets (hereinafter 'Intellectual Property Rights'). Seller will defend at its expense and will pay the cost of any settlement or damages awarded in an action brought against Buyer based on an allegation that an item sold pursuant to this contract infringes the Intellectual Property Rights of a third party. Seller's obligation to defend and indemnify Buyer is contingent on Buyer notifying Seller within ten (10) days after Buyer becomes aware of such allegations of infringement, and Seller having sole control over the defense of any allegations or actions including all negotiations for settlement or compromise. If an item sold hereunder is subject to a claim that it infringes the Intellectual Property Rights of a third party, Seller may, at its sole expense and option, procure for Buyer the right to continue using said item, replace or modify said item so as to make it noninfringing, or offer to accept return of said item and return the purchase price less a reasonable allowance for depreciation. Notwithstanding the foregoing, Seller shall have no liability for claims of infringement based on information provided by Buyer, or directed to items delivered hereunder for which the designs are specified in whole or part by Buyer, or infringements resulting from the modification, combination or use in a system of any item sold hereunder. The foregoing provisions of this Part 10 shall constitute Seller's sole and exclusive liability and Buyer's sole and exclusive remedy for infringement of Intellectual Property Rights. If a claim is based on information provided by Buyer or if the design for an item delivered hereunder is specified in whole or in part by Buyer, Buyer shall defend and indemnify Seller for all costs, expenses or judgments resulting from any claim that such item infringes any patent, trademark, copyright, trade dress, trade secret or any similar right.

**11. Force Majeure:** Seller does not assume the risk of and shall not be liable for delay or failure to perform any of Seller's obligations by reason of circumstances beyond the reasonable control of Seller (hereinafter 'Events of Force Majeure'). Events of Force Majeure shall include without limitation, accidents, acts of God, strikes or labor disputes, acts, laws, rules or regulations of any government or government agency, fires, floods, delays or failures in delivery of carriers or suppliers, shortages of materials and any other cause beyond Seller's control.

**12. Entire Agreement/Governing Law:** The terms and conditions set forth herein, together with any amendments, modifications and any different terms or conditions expressly accepted by Seller in writing, shall constitute the entire Agreement concerning the items sold, and there are no oral or other representations or agreements which pertain thereto. This Agreement shall be governed in all respects by the law of the State of Ohio. No actions arising out of the sale of the items sold hereunder or this Agreement may be brought by either party more than two (2) years after the cause of action accrues.

9/91P



**Parker Hannifin Corporation**  
 6035 Parkland Blvd.  
 Cleveland, Ohio 44124-4141  
 Telephone: (216) 896-3000  
 Fax: (216) 896-4000  
 Web site: www.parker.com

## Parker Hannifin Corporation

### About Parker Hannifin Corporation

Parker Hannifin is a leading global motion-control company dedicated to delivering premier customer service. A Fortune 500 corporation listed on the New York Stock Exchange (PH), our components and systems comprise over 1,400 product lines that control motion in some 1,000 industrial and aerospace markets. Parker is the only manufacturer to offer its customers a choice of hydraulic, pneumatic, and electro-mechanical motion-control solutions. Our Company has the largest distribution network in its field, with over 7,500 distributors serving more than 350,000 customers worldwide.

### Parker's Charter

To be a leading worldwide manufacturer of components and systems for the builders and users of durable goods. More specifically, we will design, market and manufacture products controlling motion, flow and pressure. We will achieve profitable growth through premier customer service.

### Product Information

North American customers seeking product information, the location of a nearby distributor, or repair services will receive prompt attention by calling the Parker Product Information Center at our toll-free number: 1-800-C-PARKER (1-800-272-7537). In the UK, a similar service is available by calling 0500-103-203.

#### The Aerospace Group

is a leader in the development, design, manufacture and servicing of control systems and components for aerospace and related high-technology markets, while achieving growth through premier customer service.



#### The Climate & Industrial Controls Group

designs, manufactures and markets system-control and fluid-handling components and systems to refrigeration, air-conditioning and industrial customers worldwide.



#### The Fluid Connectors Group

designs, manufactures and markets rigid and flexible connectors, and associated products used in pneumatic and fluid systems.



**The Seal Group** designs, manufactures and distributes industrial and commercial sealing devices and related products by providing superior quality and total customer satisfaction.



#### The Hydraulics Group

designs, produces and markets a full spectrum of hydraulic components and systems to builders and users of industrial and mobile machinery and equipment.



#### The Filtration Group

designs, manufactures and markets quality filtration and clarification products, providing customers with the best value, quality, technical support, and global availability.



#### The Automation Group

is a leading supplier of pneumatic and electro-mechanical components and systems to automation customers worldwide.



#### The Instrumentation Group

is a global leader in the design, manufacture and distribution of high-quality critical flow components for worldwide process instrumentation, ultra-high-purity, medical and analytical applications.



# Sales Offices Worldwide

## North America

### **Gear Pump Division Headquarters**

**101 Canterbury Road**

**Kings Mountain, NC 28086**

phone 704 730 2000

fax 704 730 5832

toll free 888 700 7411

### **Gear Pump Division Facility**

**2701 Intertech Drive**

**Youngstown, OH 44509**

phone 330 270 6000

fax 330 270 6185

toll free 888 700 7511

---

Catalog HY09-600/US, T&M, 10M 04/08

Parker Hannifin Corporation

**Gear Pump Division**

101 Caterbury Road

Kings Mountain, NC USA

[www.parker.com](http://www.parker.com)



Your Local Authorized Parker Distributor