

Coils for solenoid valves with sleeve Ø 9 mm

series USB/USBG

TECHNICAL DATA USB - USBG

Voltages	DC: 24 V AC: 24 - 110 - 220 V
Working temperature	-30 ÷ +40 °C basic version -30 ÷ +70 °C low absorption version
Versions	Basic version DC: 5 W AC: 11 VA (inrush) - 8 VA (holding) Low absorption version DC: 3 W AC: 5,6 VA (inrush) - 2,5 VA (holding)
Standard frequencies	AC 50 - 60 Hz
Voltage tolerance	-10% +10%
Coil insulation class	H (180 °C)
Solenoid rating	ED 100%
Electrical connection	Fit for connector to DIN 46244 standard See chapter Connectors on page 2.18
Protection class with connector	IP 65 EN 60529

MATERIALS USB - USBG

Body	Glass stiffened polyamide
Coil winding	Copper wire

USB

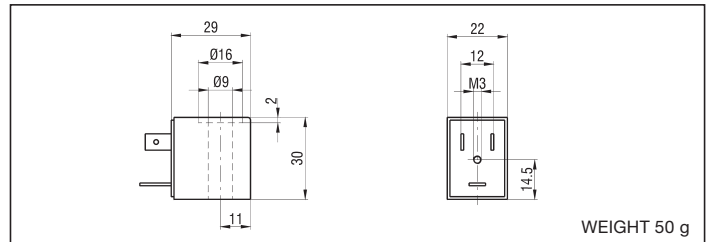

DESCRIPTION	TYPE*
Coil 22 mm 24 V DC	USB/02400
Coil 22 mm 24 V AC	USB/02450-60
Coil 22 mm 110 V AC	USB/11050-60
Coil 22 mm 220 V AC	USB/22050-60
OTHER VOLTAGES	USB/...

*/EX Consistent with the ATEX directive II 3G Ex nA IIC T4 Gc -30°C ≤ Ta ≤ 40°C
II 3D Ex tc IIIC T135°C IP65 Dc

E.G.: **USB/02400/EX**

P.S.: ADD THE SUFFIX "-BA" JUST AFTER THE USB TYPE, TO ORDER THE LOW ABSORPTION VERSION COILS. E.G.: **USB-BA/02400**

USBG

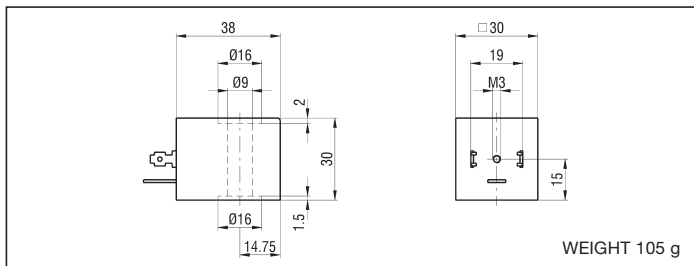

DESCRIPTION	TYPE*
Coil 30 mm 24 V DC	USBG/02400
Coil 30 mm 24 V AC	USBG/02450-60
Coil 30 mm 110 V AC	USBG/11050-60
Coil 30 mm 220 V AC	USBG/22050-60
OTHER VOLTAGES	USBG/...

*/EX Consistent with the ATEX directive II 3G Ex nA IIC T4 Gc -30°C ≤ Ta ≤ 40°C
II 3D Ex tc IIIC T135°C IP65 Dc

E.G.: **USBG/02400/EX**

P.S.: ADD THE SUFFIX "-BA" JUST AFTER THE USBG TYPE, TO ORDER THE LOW ABSORPTION VERSION COILS. E.G.: **USBG-BA/02400**

Coils for solenoid valves side 30 mm with sleeve Ø 9 mm conform to ATEX 2GD directive

series USBG2/EX

TECHNICAL DATA

Voltages	DC: 24 V AC: 24 V
Working temperature	-50 ÷ +50 °C
Versions	DC: 3 W AC: 4,8 VA (inrush) - 3,2 VA (holding)
Standard frequencies	AC 50 - 60 Hz
Voltage tolerance	-10% +10%
Coil insulation class	H (180 °C)
Solenoid rating	ED 100%
Connectors	3 m long emerging cable
Protection class	IP 66

MATERIALS

Body	Glass stiffened polyamide
Coil winding	Copper wire

USBG 2 - ATEX 2GD

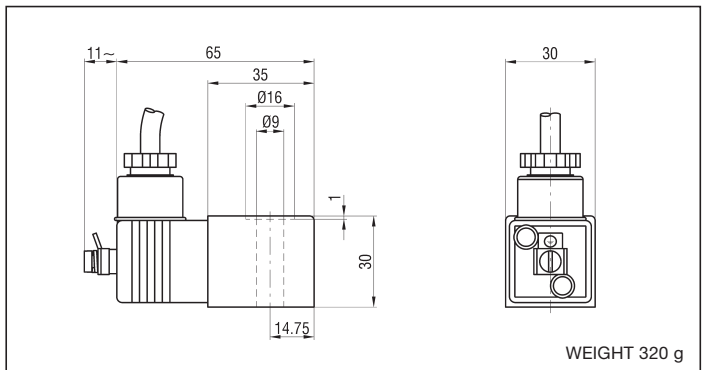

DESCRIPTION	TYPE*
Coil 30 mm 24 V DC	USBG2/02400/EX
Coil 30 mm 24 V AC	USBG2/02450-60/EX

*/EX Consistent with the ATEX directive II 2G Ex mb IIC T5 Gb -50°C ≤ Ta ≤ 40°C
II 2D Ex tb IIIC T95°C IP65 Db

E.G.: **USBG2/02400/EX**

P.S.: For different voltages, please contact our commercial office