

Flow divider with independent phase correction and anticavitation valves for each element

Codice:

9RV NN M CC

9RV02B49

| | |
|-----|-------------------------------------|
| 9RV | Flow Divider Typology |
| NN | Number of elements |
| M | Code of setting range of the valves |
| CC | Displacement Code |

| TABELLA "M" | |
|-------------|--------------|
| A | 10÷ 105 bar |
| B | 70÷ 210 bar |
| C | 140÷ 350 bar |

Example: Flow divider with two elements (same displacement): :
RV-2V / 11 x 2 with valve 10 ÷ 105 bar

9RV 02 A 47

Example: Flow Divider with 4 elements with different displacement (max 7):
RV-2V / 9+14+14+22 with valve 70 ÷ 210 bar

9RV 04 B 45 49 49 55

NOTE: to define codes for flow dividers with more than 7 different displacement, please contact our sales department.

Table: 1

| Displacem. Cm ³ /rev | CC Code | Max Pressure bar | One element flow rate l/min | | |
|------------------------------------|------------|------------------------|--------------------------------|-------------|------|
| | | | MIN | RECOMMENDED | MAX |
| 4 | 41 | 210 | 4,8 | 7,6 | 10 |
| 6 | 43 | 210 | 7,2 | 10,8 | 15 |
| 9 | 45 | 210 | 10,8 | 15,1 | 22,5 |
| 11 | 47 | 210 | 13,2 | 19,4 | 27,5 |
| 14 | 49 | 200 | 16,8 | 25,9 | 35 |
| 17 | 51 | 200 | 20,4 | 30,2 | 42,5 |
| 19 | 53 | 190 | 22,8 | 34,6 | 47,5 |
| 22 | 55 | 180 | 26,4 | 41 | 55 |
| 26 | 57 | 160 | 31,2 | 45,4 | 65 |
| 30 | 59 | 160 | 36 | 54 | 75 |
| 34 | 61 | 140 | 40,8 | 61,6 | 85 |
| 40 | 63 | 130 | 48 | 71,3 | 100 |

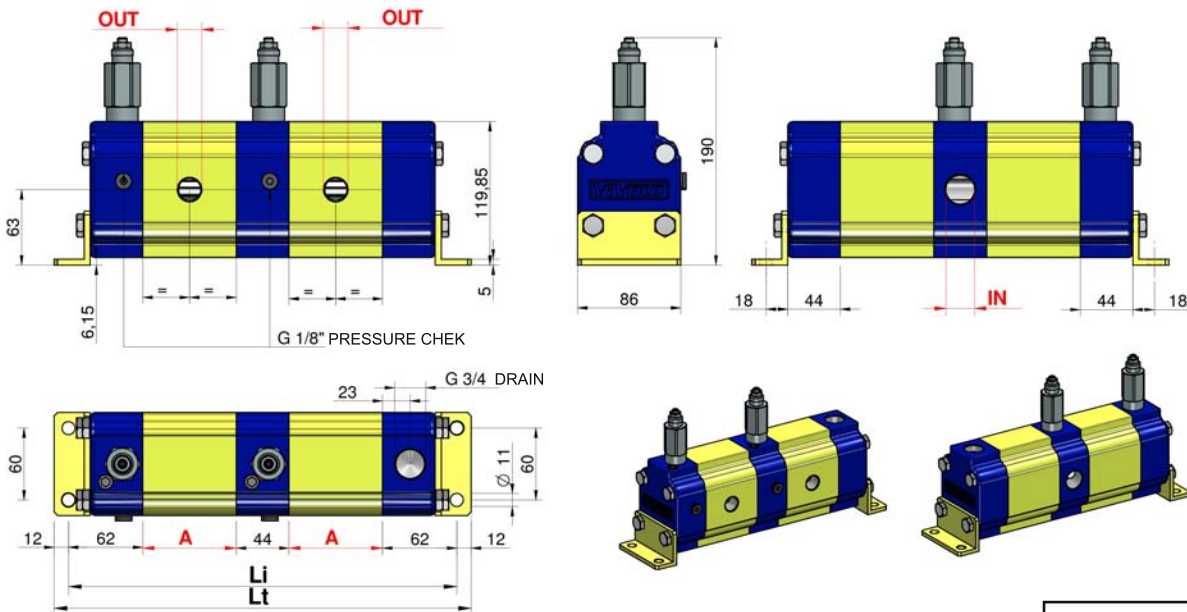

REFERENCES: RV201

Table: 2

Li = Distance between fixing hole centres (single displacement flow divider)

| Cm ³ /rev | A | IN | OUT | Number of elements | | | | | | | | | | | | | | |
|----------------------|-----|---------|---------|--------------------|-----|-----|-----|-----|------|------|------|------|------|------|------|------|------|------|
| | | | | 2 | 3 | 4 | 5 | 6 | 7 | 8 | 9 | 10 | 11 | 12 | 13 | 14 | 15 | 16 |
| 4 | 47 | 3/4 BSP | 1/2 BSP | 262 | 353 | 444 | 535 | 626 | 717 | 808 | 899 | 990 | 1081 | 1172 | 1263 | 1354 | 1445 | 1536 |
| 6 | 50 | 3/4 BSP | 1/2 BSP | 268 | 362 | 456 | 550 | 644 | 738 | 832 | 926 | 1020 | 1114 | 1208 | 1302 | 1396 | 1490 | 1584 |
| 9 | 54 | 3/4 BSP | 1/2 BSP | 276 | 374 | 472 | 570 | 668 | 766 | 864 | 962 | 1060 | 1158 | 1256 | 1354 | 1452 | 1550 | 1648 |
| 11 | 58 | 3/4 BSP | 1/2 BSP | 284 | 386 | 488 | 590 | 692 | 794 | 896 | 998 | 1100 | 1202 | 1304 | 1406 | 1508 | 1610 | 1712 |
| 14 | 64 | 3/4 BSP | 1/2 BSP | 296 | 404 | 512 | 620 | 728 | 836 | 944 | 1052 | 1160 | 1268 | 1376 | 1484 | 1592 | 1700 | 1808 |
| 17 | 68 | 3/4 BSP | 1/2 BSP | 304 | 416 | 528 | 640 | 752 | 864 | 976 | 1088 | 1200 | 1312 | 1424 | 1536 | 1648 | 1760 | 1872 |
| 19 | 72 | 3/4 BSP | 1/2 BSP | 312 | 428 | 544 | 660 | 776 | 892 | 1008 | 1124 | 1240 | 1356 | 1472 | 1588 | 1704 | 1820 | 1936 |
| 22 | 78 | 3/4 BSP | 1/2 BSP | 324 | 446 | 568 | 690 | 812 | 934 | 1056 | 1178 | 1300 | 1422 | 1544 | 1666 | 1788 | 1910 | 2032 |
| 26 | 82 | 1 BSP | 3/4 BSP | 332 | 458 | 584 | 710 | 836 | 962 | 1088 | 1214 | 1340 | 1466 | 1592 | 1718 | 1844 | 1970 | 2096 |
| 30 | 90 | 1 BSP | 3/4 BSP | 348 | 482 | 616 | 750 | 884 | 1018 | 1152 | 1286 | 1420 | 1554 | 1688 | 1822 | 1956 | 2090 | 2224 |
| 34 | 97 | 1 BSP | 3/4 BSP | 362 | 503 | 644 | 785 | 926 | 1067 | 1208 | 1349 | 1490 | 1631 | 1772 | 1913 | 2054 | 2195 | 2336 |
| 40 | 106 | 1 BSP | 3/4 BSP | 380 | 530 | 680 | 830 | 980 | 1130 | 1280 | 1430 | 1580 | 1730 | 1880 | 2030 | 2180 | 2330 | 2480 |

Table: 3 in this table the number of inlets in function of the number of elements are indicated.

| Number of elements | 2 | 3 | 4 | 5 | 6 | 7 | 8 | 9 | 10 | 11 | 12 | 13 | 14 | 15 | 16 |
|-----------------------|---|---|---|---|---|---|---|---|----|----|----|----|----|----|----|
| "IN" Number of inlets | 1 | 1 | 2 | 2 | 3 | 3 | 4 | 4 | 5 | 5 | 6 | 6 | 7 | 7 | 8 |

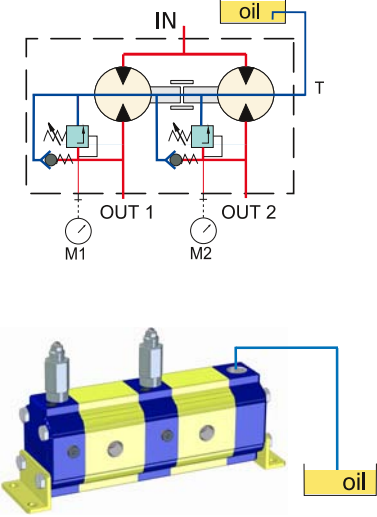
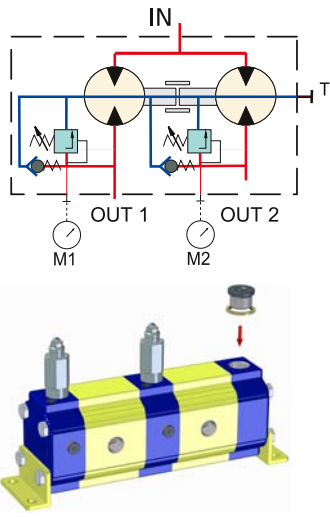
| <p>EXTERNAL DRAIN <i>STANDARD SETUP</i></p> | <p>INTERNAL DRAIN</p> |
|--|--|
| <p>For the correct functioning of the flow divider, it has to be installed <i>under the oil level</i>. The drain tube has to pick up under the oil level and it has not to aspire air.</p> | <p>To predispose the divider to the internal drain, plug the 3/4" G drain port (T)</p> <p>Note: with this configuration the function of anticavitation valves is annulled</p> |
|  |  |

In **table 1** the functioning range of single flow divider elements is indicated.

The higher is the feeding capacity (q), the higher is the precision of flow division, but in opposition there are losses of loading and higher noise. Therefore we suggest to feed the elements with capacities equal or a few superior to the ones indicated in the column "**RECOMMENDED**".

It's important remember to verify the capacities even in phase of flow reunion.

The pressures indicated are to be considered as maximum of functioning, the flow divider is able to bear peaks of pressure 20% superior.

How to calculate the "Li" and "Lt" measures of flow dividers:

From **table 2** it is possible to obtain the "Li" measure for flow dividers up to 16 elements with equal displacements; for flow dividers with different elements or with more than 16 elements the "Li" and "Lt" measure have to be calculated by the following formula:

$$Li = [(n-1) \times 44] + 124 + (A1 + A2 + A3 + \dots)$$

$$124 = 62 + 62$$

n = Number of elements of flow divider

A1... An = heights of elements of flow divider

$$Lt = Li + 24$$

$$24 = 12 + 12$$

EXAMPLE: To obtain the measures **Li** and **Lt** of a flow divider with three elements (n=3), **RV-2V 19 + 11 + 9**

Distance between fixing hole centres

$$Li = [(3-1) \times 44] + 124 + 72 + 58 + 54 = 396 \text{ mm}$$

Total Length

$$Lt = 396 + 24 = 420 \text{ mm}$$

In **table 3** the number of inlets in fuction of the number of elements are indicated.

For flow dividers with many inlets, as they are all communicating it is even possible to use only one of them, by plugging the other ones. We suggest to use at least one **3/4" BSP** inlet every **80 l/min** capacity and at least one **1" BSP** inlet every **120 l/min** capacity

To obtain errors of division inferior to 3% there must be no difference of pressure between the elements superior to 30 bar. To obtain high precisions the respect of the following parametres is also important:

- Environment temperature: -10°C ÷ +60°C Oil temperature: +30°C ÷ +60°C
- Hydraulic oil based on hlp, hv (din 51524) minerals Oil Viscosity 20 ÷ 40 cSt
- Oil filtering 10 ÷ 25 µ