

4/4 controlled directional valve, directly operated, with electric position feedback and integrated electronics (OBE)

RE 29037/03.10
Replaces: 10.05

1/12

Type 4WRPEH10

Size 10
Component series 2X
Maximum operating pressure P, A, B 315 bar, T 250 bar
Rated flow 50...100 l/min (Δp 70 bar)

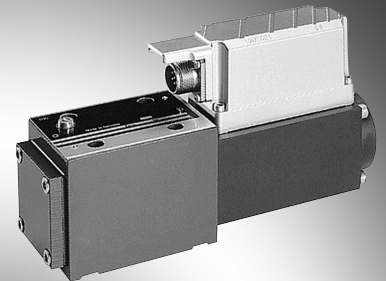

Type 4WRPEH10

Table of contents

Contents	Page
Features	1
Ordering code	2
Function, section	3
Symbols	3
Test and service device	3
Technical data	4 and 5
Electrical connection	6
Technical notes with regard to cable	6
Integrated electronics	7 and 8
Characteristic curves	9 and 10
Unit dimensions	11

Features

- Directly actuated controlled directional valve, with control spool and sleeve in servo quality
- Single-side operated, 4/4 fail-safe position in deactivated state
- Electric position feedback and integrated electronics (OBE), calibrated in the factory
- Electric port 6P+PE
Signal input of differential amplifier with interface A1 ± 10 V or interface F1 4...20 mA ($R_{sh} = 200 \Omega$)
- Used for electro-hydraulic control systems in production and test plants

Information on available spare parts:
www.boschrexroth.com/spc

Ordering code

4WRP	E	H	10		B			- 2X/	G24	K0/		M	*
------	---	---	----	--	---	--	--	-------	-----	-----	--	---	---

With **integrated electronics** = E

Control piston/sleeve = H

Size = 10

Control spool symbol

4/4 way design

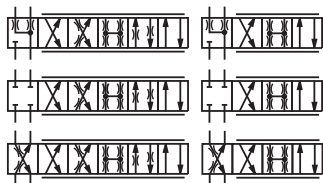
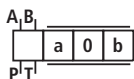

With symbols C5 and C1:

P → A: q_V B → T: $q_V/2$

P → B: $q_V/2$ A → T: q_V

Installation side of

the inductive position transducer

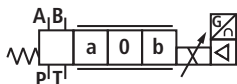

(standard)

= B

Further details in the plain text

Seal material

M = NBR seals, suitable for mineral oils (HL, HLP) according to DIN 51524

Interface of the control electronics

A1 = Command value input ±10 V

F1 = Command value input 4...20 mA

Electric port

K0 = Without mating connector, With connector according to DIN 43563-AM6 Mating connector— separate order

Supply voltage of the control electronics

G24 = +24 V direct current

2X = Component series 20 to 29 (identical installation and connection dimensions)

Flow characteristics

Linear

P = Inflected characteristic curve

Rated flow

at 70 bar valve pressure difference (35 bar/control edge)

50 = 50 l/min
100 = 100 l/min

Function, section

General

In the field of integrated electronics, the specified command value is compared with the actual position value. In case of deviations from the standard, the lifting solenoid is activated. Due to the changed magnetic force, the lifting solenoid adjusts the control valve against the spring.

Lifting/control cross-section are adjusted proportionally to the command value. In case of a command value provision of 0 V, the electronics adjusts the control valve against the spring to center position. In deactivated condition, the spring is unloaded to a maximum and the valve is in fail-safe position.

Switch-off behavior

If the electronics is switched off, the valve immediately moves to the secured basic position (fail safe).

In this process, the P-B/A-T position is passed which might cause movements at the controlled component. This must be taken into account when designing the plant.

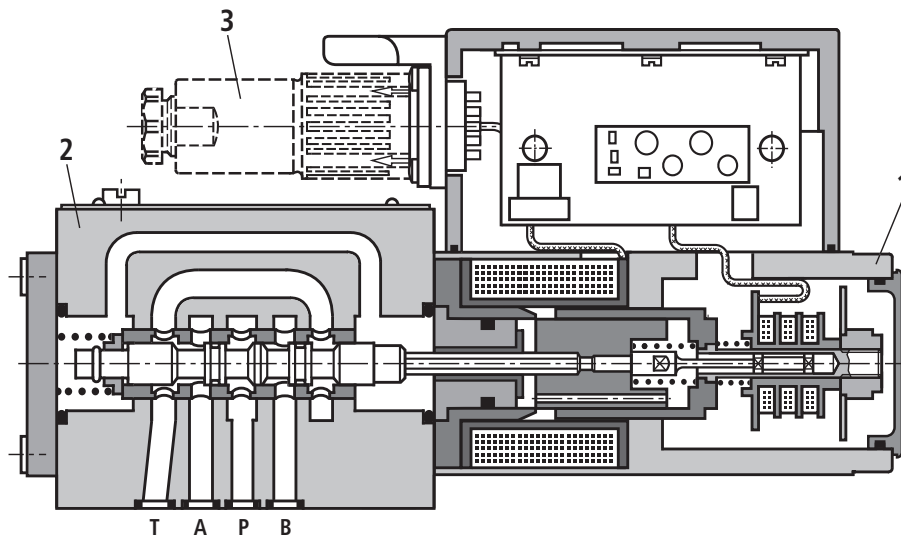

- 1 Control solenoid with position transducer
- 2 Valve bodies
- 3 Mating connectors

Symbols

	L: Linear	P: Inflection 40 %

Test and service device

- Service case Type VT-VETSY-1 with test device, see RE 29685
- Measuring adapter 6P+PE Type VT-PA-2, see RE 30068

Technical data

general						
Type	Gate valve, directly operated, with steel sleeve					
Actuation	Proportional solenoid with position control, OBE					
Type of connection	Plate port, porting pattern (ISO 4401-05-04-0-05)					
Installation position	Any					
Ambient temperature range	°C	-20...+50				
Weight	kg	7,1				
Vibration resistance, test condition	Max. 25 g, space vibration test in all directions (24 h)					
hydraulic (measured with HLP 46, $\vartheta_{oil} = 40 \text{ °C} \pm 5 \text{ °C}$)						
Hydraulic fluid	Hydraulic oil according to DIN 51524...535, other media upon request					
Viscosity range	Recommended	mm ² /s	20...100			
	Max admissible	mm ² /s	10...800			
Hydraulic fluid temperature range	°C	-20...+70				
Maximum admissible degree of contamination of the hydraulic fluid cleanliness class according to ISO 4406 (c)	Class 18/16/13 ¹⁾					
Flow direction	According to symbol					
Rated flow at $\Delta p = 35 \text{ bar per edge}^2)$	l/min	50 (1:1)	50 (2:1)	100 (1:1)	100 (2:1)	
Max operating pressure	Port P, A, B	bar	315			
	Orifice T	bar	250			
Limitation of use Δp pressure loss at the valve C, C3, C5	C, C3, C5	bar	315	315	160	160
	$Q_{Vnom} > Q_N$ valves C4, C1	bar	250	250	100	100
Zero flow at 100 bar	Linear characteristic curve L	cm ³ /min	< 1200	< 1200	< 1500	< 1000
	Inflected characteristic curve P	cm ³ /min	< 600	< 500	< 600	< 600
Fail-safe position						
C	Flow at $\Delta p = 35 \text{ bar per edge}$	l/min	50	50	100	100
C3, C5	Zero flow at 100 bar	cm ³ /min	50 P-A			
C3, C5	Flow at $\Delta p = 35 \text{ bar per edge}$	l/min	70 P-B			
C4, C1	Zero flow at 100 bar	cm ³ /min	110...100 A-T			
C4, C1	Flow at $\Delta p = 35 \text{ bar per edge}$	l/min	10...25 B-T			
Reaching the fail-safe position	0 bar	12 ms	50 P-A			
			70 P-B			
			70 A-T			
Reaching the fail-safe position	100 bar	16 ms	50 B-T			
			70 A-T			
			50 B-T			

¹⁾ In hydraulic systems, the cleanliness classes indicated for components must be observed. Effective filtration prevents faults and at the same time increases the service life of the components. For the choice of filters, see technical data sheets RE 50070, RE 50076 and RE 50081.

²⁾ Flow at different Δp $Q_x = Q_{nom} \cdot \sqrt{\frac{\Delta p_x}{35}}$

Technical data

static / dynamic		
Hysteresis	%	$\leq 0,2$
Manufacturing tolerance q_{\max}	%	< 10
Actuating time for signal step 0...100 %	ms	≤ 25
Temperature drift		Zero shift $< 1 \%$ at $\Delta T = 40 \text{ }^\circ\text{C}$
Zero compensation		ex factory $\pm 1 \%$
electric, control electronics integrated in the valve		
Relative duty cycle	%	100 ED
Protection class		IP 65 according to DIN 40050 and IEC 14434/5
Port		Mating connector 6P+PE, DIN 43563
Supply voltage		24 V = $_{\text{nom}}$
Terminal A:		min. 21 V = / max. 40 V =
Terminal B: 0 V		Ripple max. 2 V =
Max. power consumption		60 VA
Fuse protection, external		2.5 A _F
Input, version A1		Differential amplifier, $R_i = 100 \text{ k}\Omega$
Terminal D: U_E		0...±10 V
Terminal E:		0 V
Input, version F1		Load, $R_{\text{sh}} = 200 \text{ }\Omega$
Terminal D: I_{D-E}		4...(12)...20 mA
Terminal E: I_{D-E}		Current loop I_{D-E} feedback
Max. voltage of the differential inputs almost 0 V		D → B } max. 18 V = E → B }
Test signal, version A1		LVDT
Terminal F: U_{test}		0...±10 V
Terminal C:		Reference 0 V
Test signal, version F1		LVDT signal 4...20 mA, at external load 200...500 Ω max.
Terminal F: I_{F-C}		4...20 mA output
Terminal C: I_{F-C}		Current loop I_{F-C} feedback
Protective earthing conductor and shielding		See pin assignment (CE-compliant installation)
Adjustment		Calibrated in the factory, see characteristic curve of the valve
Electromagnetic compatibility tested according to		EN 61000-6-2: 2005-08 EN 61000-6-3: 2007-01

Version A1: Standard

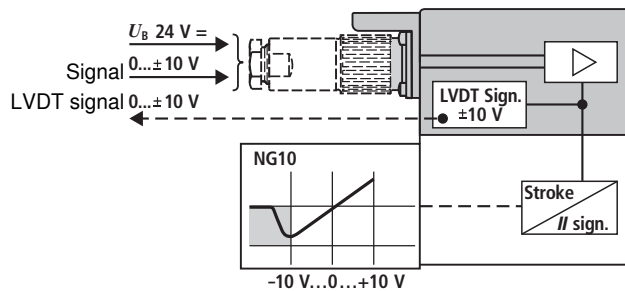

Version F1: mA signal

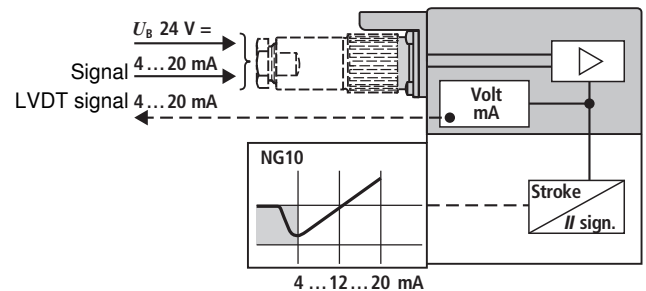

Electrical connection

Electrical data, see page 5

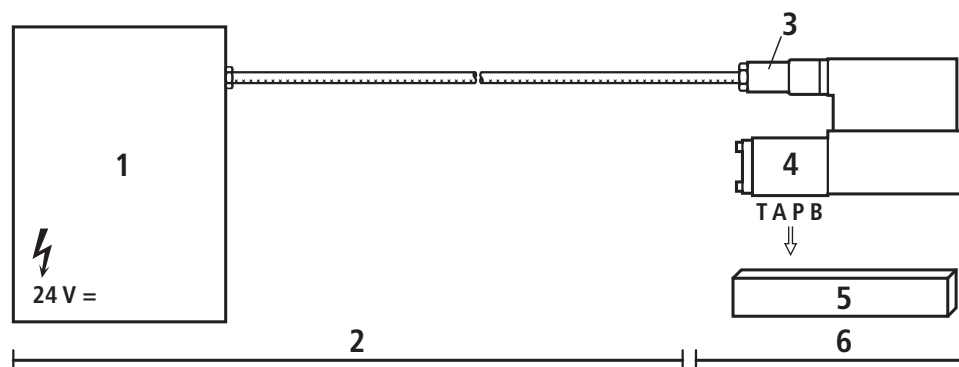

- 1 Control
- 2 On the customer side
- 3 Mating connector
- 4 Valve
- 5 Contact surface
- 6 On Rexroth side

Technical notes with regard to cable

- Version:**
- Multi-core wire
 - Litz wire structure, extra fine wire according to VDE 0295, class 6
 - Protective earthing conductor, green-yellow
 - Cu shielding braid
- Type:**
- e.g. Oilflex-FD 855 CP (Company Lappkabel)
- Number of wires:**
- Determined by the valve type, connector type and signal configuration
- Line Ø:**
- 0.75 mm² to 20 m of length
 - 1.0 mm² to 40 m of length
- OuterØ:**
- 9.4...11.8 mm – Pg11
 - 12.7...13.5 mm – Pg16

Note

Supply voltage 24 V = _{nom}, if the value falls below 18 V = an internal fast switch-off is effected which can be compared with "Release OFF".

Additionally for version F1:

$I_{D-E} \geq 3 \text{ mA}$ – valve is active

$I_{D-E} \leq 2 \text{ mA}$ – valve is deactivated.

Electric signals taken out via control electronics (e.g. actual value) may not be used for the switch-off of safety-relevant machine functions! (See also the European standard "Safety requirements for fluid power systems and their components - Hydraulics", EN 982.)

Integrated electronics

Block diagram/Pinout

Version A1: $U_{D-E} \pm 10\text{ V}$

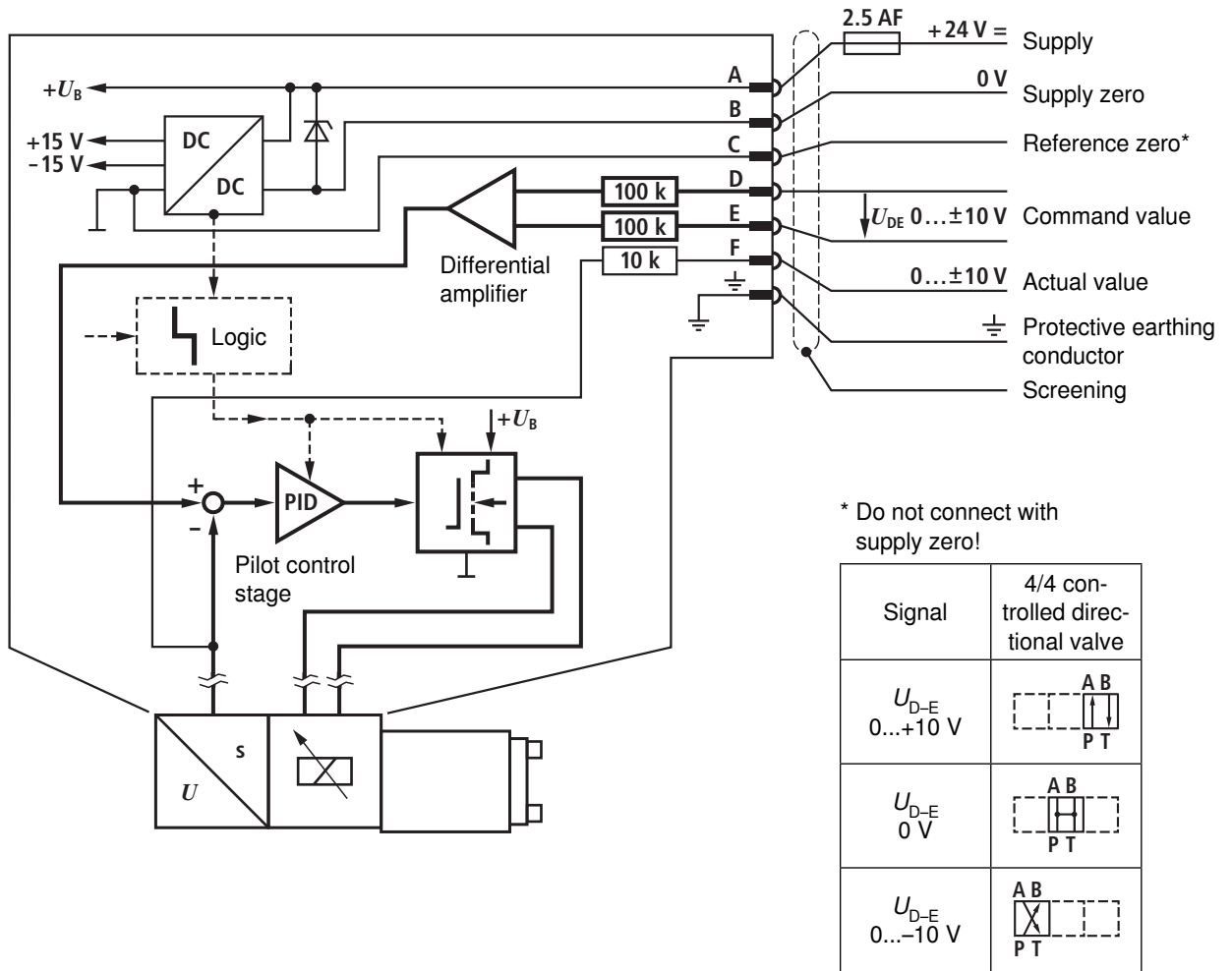

Pin assignment 6P+PE

Version A1: $U_{D-E} \pm 10\text{ V}$

($R_i = 100\text{ k}\Omega$)

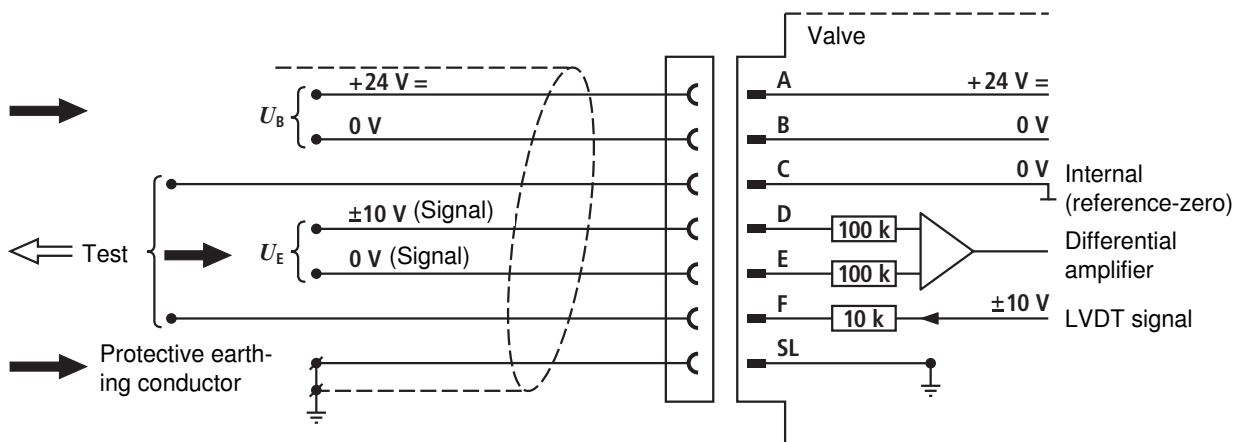

Integrated electronics

Block diagram/Pinout

Version F1: I_{D-E} 4...12...20 mA

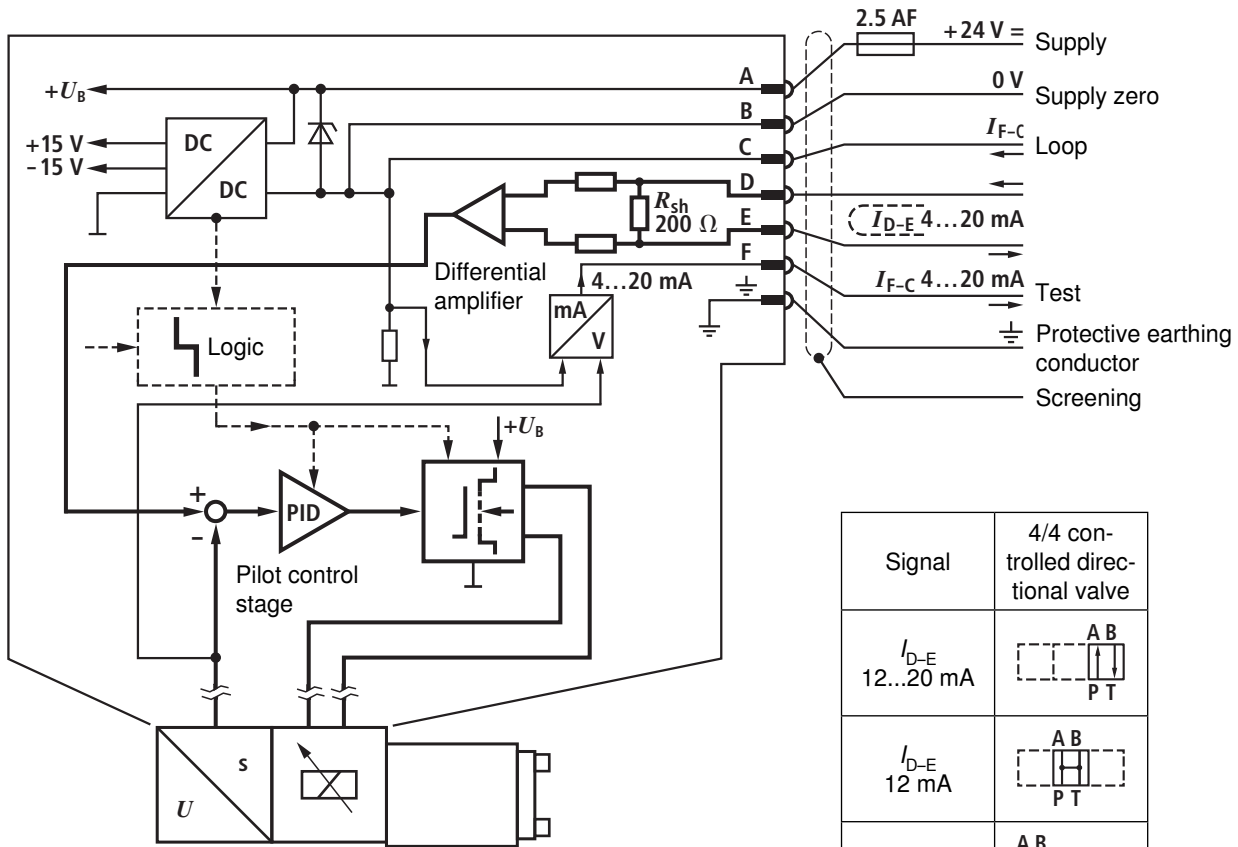

Signal	4/4 controlled directional valve
I_{D-E} 12...20 mA	
I_{D-E} 12 mA	
I_{D-E} 4..0.12 mA	

$I_{D-E} \leq 2$ mA: Valve inactive

Pin assignment 6P+PE

Version F1: I_{D-E} 4...12...20 mA

($R_{sh} = 200 \Omega$)

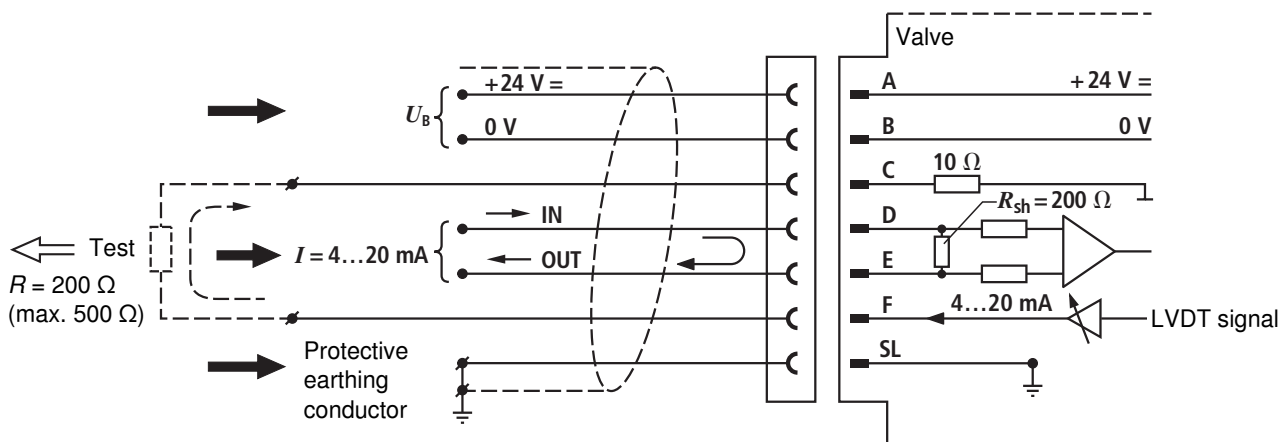

Characteristic curves (measured with HLP 46, $\vartheta_{oil} = 40 \text{ }^\circ\text{C} \pm 5 \text{ }^\circ\text{C}$)

Flow – signal function
 $Q = f(U_{D-E})$
 $Q = f(I_{D-E})$

Flow characteristics
 L: Linear 1:1

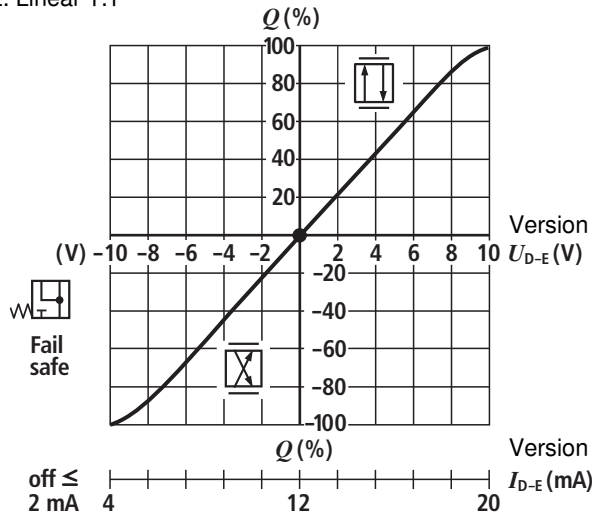

Flow characteristics
 L: Linear 2:1

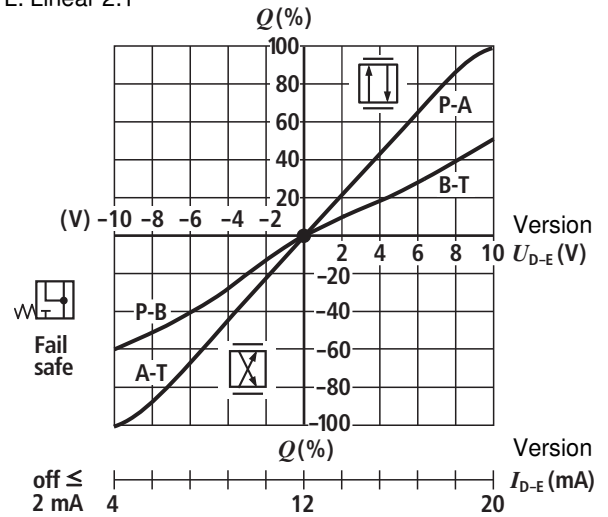

Flow characteristics
 P: (Inflection 40%) 1:1

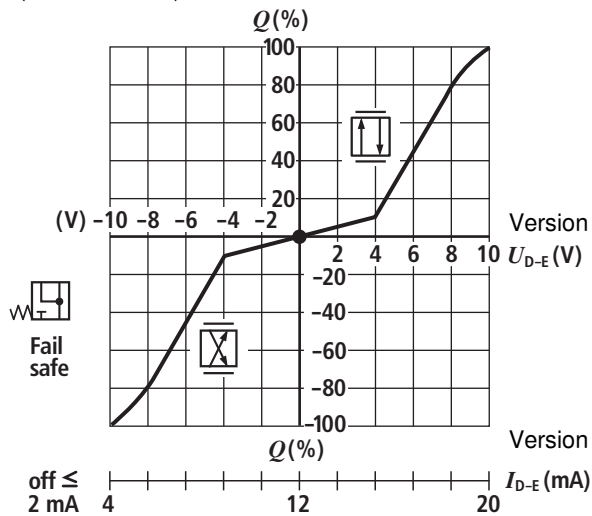

Flow characteristics
 P: (Inflection 40%) 2:1

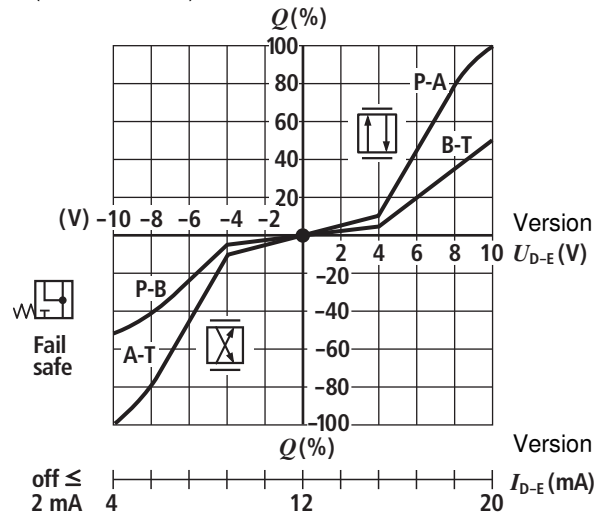

Characteristic curves (measured with HLP 46, $\vartheta_{oil} = 40 \text{ }^\circ\text{C} \pm 5 \text{ }^\circ\text{C}$)

Pressure gain

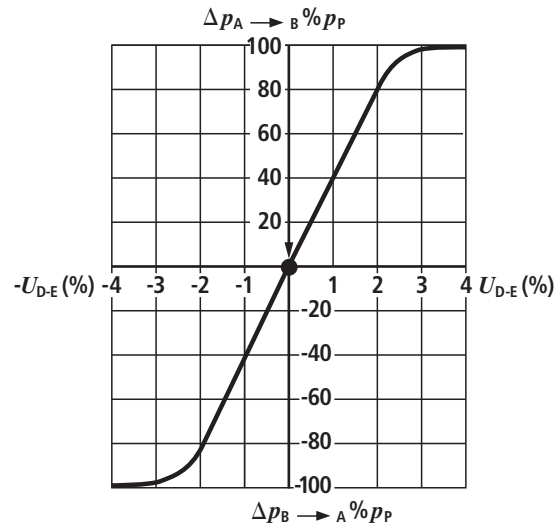
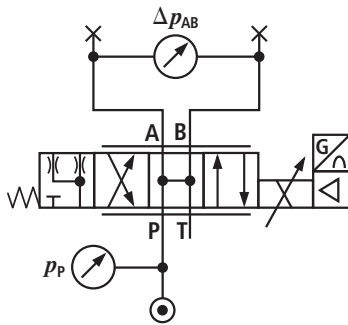

Bode diagram

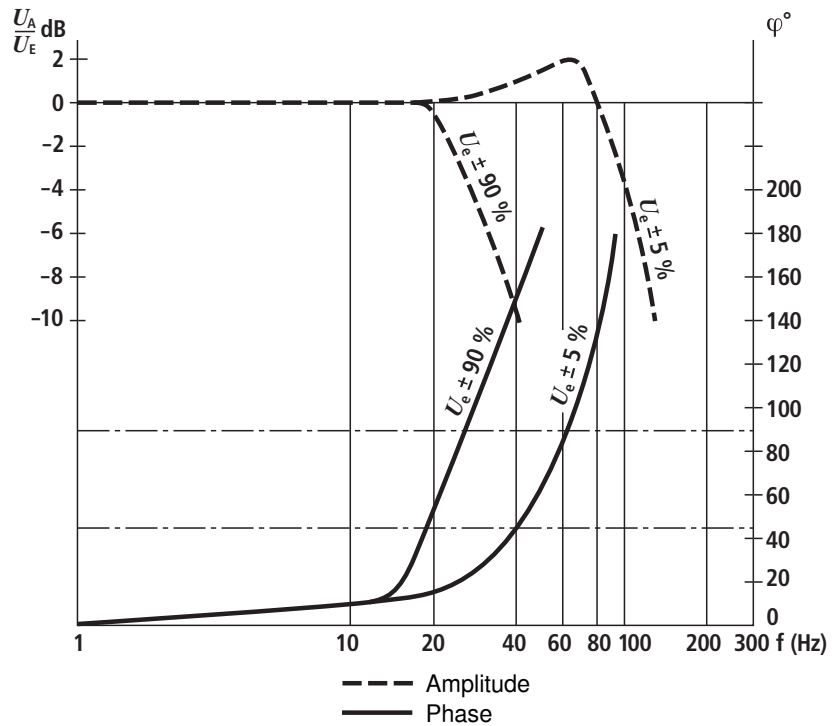
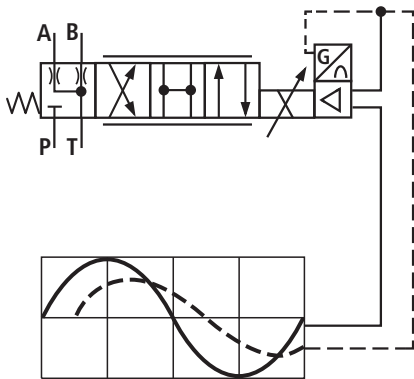

Unit dimensions (dimensions in mm)

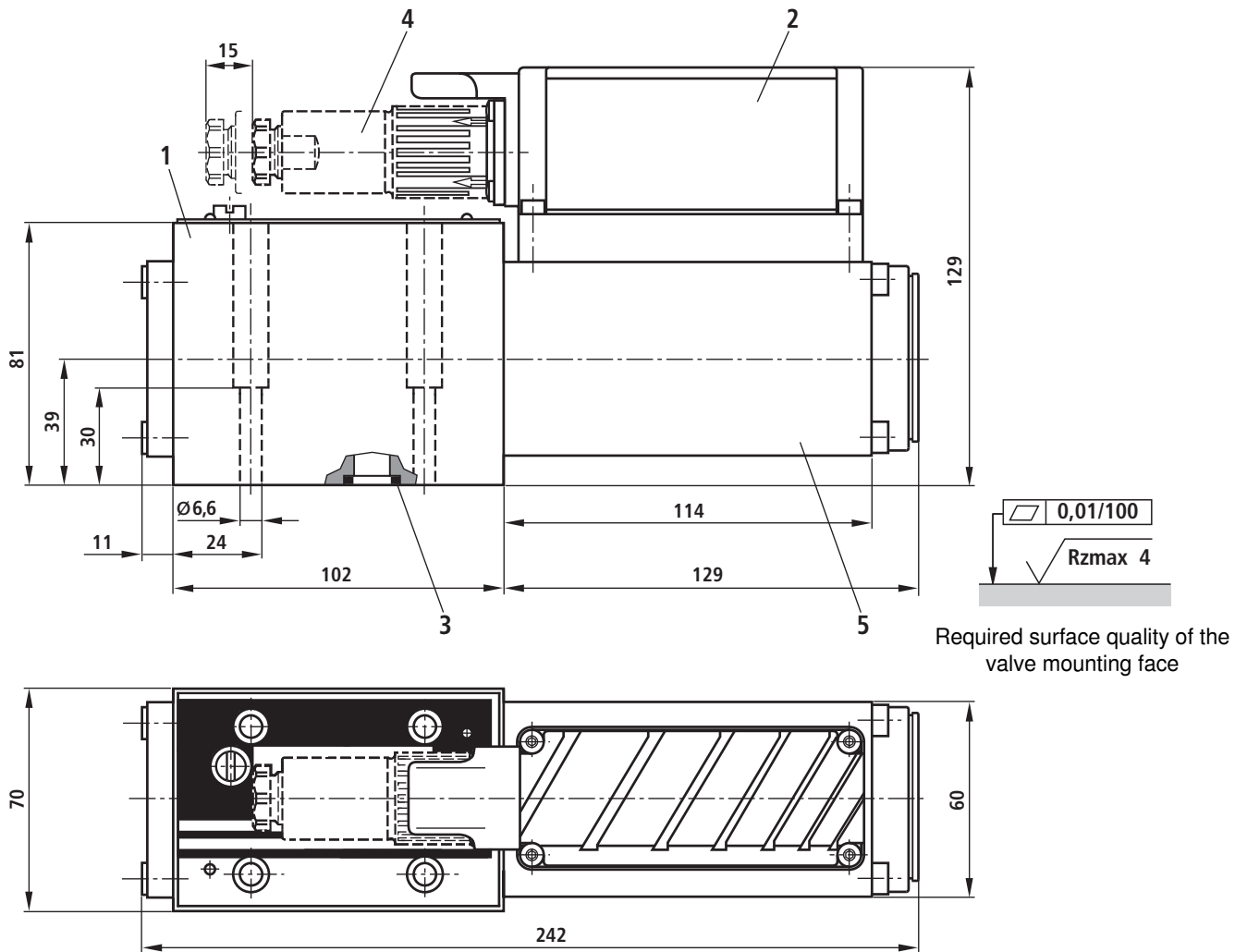

Required surface quality of the valve mounting face

- 1 Valve housing
- 2 Integrated electronics
- 3 O-rings $\varnothing 12 \times 2$ (ports P, A, B, T, T1)
- 4 Mating connector
see technical data sheet RE 08008
(separate order)
- 5 Control solenoids with position transducer
- 6 Machined valve mounting face, porting pattern according to ISO 4401-05-04-0-05
Deviating from the standard:
Ports P, A, B, T, T1 $\varnothing 10.5$ mm

Subplates, see technical data sheet RE 45055
(separate order)

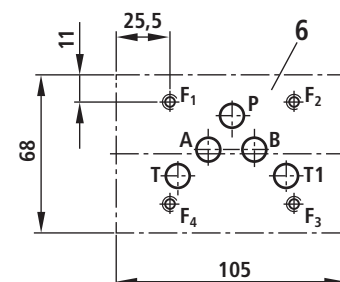

Valve mounting screws (separate order)

The following valve mounting screws are recommended:

4 hexagon socket head cap screws ISO 4762-M6x40-10.9-N67F82170

(galvanized according to N67F82170)

Tightening torque $M_A = 11 \pm 3$ Nm

Mat. no. 2910151209

or

4 hexagon socket head cap screws ISO 4762-M6x40-10.9

(friction rate $\mu_{\text{total}} = 0.12 - 0.17$)

Notes

Bosch Rexroth AG
Hydraulics
Zum Eisengießer 1
97816 Lohr am Main, Germany
Phone +49 (0) 93 52 / 18-0
Fax +49 (0) 93 52 / 18-23 58
documentation@boschrexroth.de
www.boschrexroth.de

© This document, as well as the data, specifications and other information set forth in it, are the exclusive property of Bosch Rexroth AG. It may not be reproduced or given to third parties without its consent.

The data specified above only serve to describe the product. No statements concerning a certain condition or suitability for a certain application can be derived from our information. The information given does not release the user from the obligation of own judgment and verification. It must be remembered that our products are subject to a natural process of wear and aging.