

X Series SAP 50

Nylon air breather filter

Dimensions

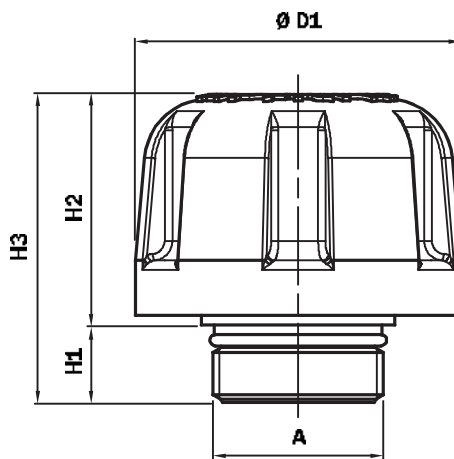
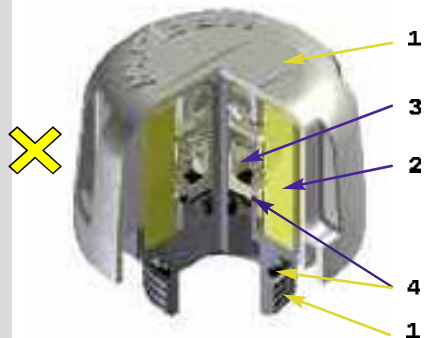

SAP050 (Materials)

- 1 - Cover/Connection: Nylon
- 2 - Filter element: Impregnated paper
Yr þ gvéð uvé
- 3 - Pressurisation: Nylon
Galvanised steel
NBR
- 4 - Seal: NBR

Flow rate with Δp : 0,02 bar

Filtration I_N /min
10 μm 204

Weights

SAP 050: 0,040 kg

Connection to reservoir " A "

Type X 50				
G1	G2	G3	G4	G5
G 1/4"	G 3/8"	G 1/2"	G 3/4"	1/4" NPT
G6	G7	G8	G9	G10
3/8" NPT	1/2" NPT	3/4" NPT	SAE 6	SAE 12

Quantity per pack Number of Parts

SAP 50	10
--------	----

Dimensions

Type SAP	D1	H1	H2	H3
50 G1				
50 G2				
50 G3				
50 G4	50,5	12	36	48
50 G5				
50 G6				
50 G7				
50 G8				
50 G9	50,5	14,5	35	50
50 G10				

Ordering information

Breather filter
SAP **G3** **L10** **A** **0** **P01**
Example: SAP50 G4 L10 A 0 P01

1 - Connection to reservoir

X G1	G 1/4"
G2	G 3/8"
X G3	G 1/2"
G4	G 3/4"
G5	1/4" NPT
G6	3/8" NPT
G7	1/2" NPT
G8	3/4" NPT
G9	SAE 6
G10	SAE 12

2 - Filter element

X L03	3 @m - Impregnated paper
X L10	10 @m - Yr þ gvéð uvé

3 - Seal

X A	NBR
------------	-----

4 - Pressurisation valve

X 0	L yð r gz
1	Pressurisation valve 0,5 bar Only for connection: G2 - G3 - G4 - G6 G7 - G8 - G10

5 - Options

X P01	MP Filtri standard
--------------	--------------------