

SV08-20 Poppet, 2-Way, Normally Closed

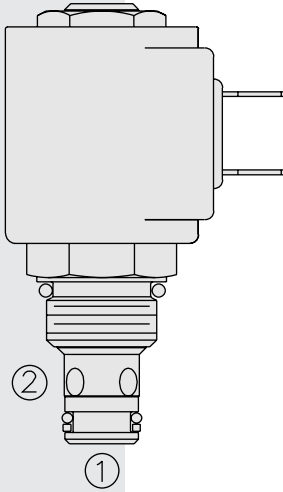

DESCRIPTION

A solenoid-operated, 2-way, normally closed, piloted poppet-type, screw-in hydraulic cartridge valve, intended to act as a blocking or load-holding device for low flow circuits.

OPERATION

When de-energized, the **SV08-20** acts as a check valve, allowing flow from 1 to 2, while blocking flow from 2 to 1.

When energized, the cartridge's poppet lifts to open the 2 to 1 flow path. In this mode, flow from 1 to 2 is severely restricted. If this path is required, see model SV08-22, page 1.041.1.

Operation of Manual Override Option: To override, push button in, twist counter-clockwise 180°, and release. In this position, the valve will remain open.

To return to normal operation, push button in, twist clockwise 180°, and release. Override will be detented in this position.

FEATURES

- Continuous-duty rated coil.
- Hardened seat for long life and low leakage.
- Optional coil voltages and terminations.
- Cartridges are voltage interchangeable.
- Unitized, molded coil design.
- Manual override option.
- Optional waterproof E-Coils rated up to IP69K.
- Industry common cavity.
- Compact size.

RATINGS

Operating Pressure: 207 bar (3000 psi)

Proof Pressure: 255 bar (3700 psi)

Flow: See Performance Chart

Internal Leakage: 0.15 cc/minute (3 drops/minute) max. at 207 bar (3000 psi)

Temperature: -40 to 120 °C with standard Buna seals

Coil Duty Rating: Continuous from 85% to 115% of nominal voltage

Response Time: First indication of change of state with 100% voltage supplied at 80% of nominal flow rating: Energized: 40 ms De-energized: 46 ms

Initial Coil Current Draw at 20 °C: Standard Coil: 1.2 amps at 12 Vdc; 0.13 amps at 115 Vac (full wave rectified).

E-Coil: 1.4 amps at 12 Vdc; 0.7 amps at 24 Vdc

Minimum Pull-in Voltage: 85% of nominal at 207 bar (3000 psi)

Filtration: See page 9.010.1

Fluids: Mineral-based or synthetics with lubricating properties at viscosities of 7.4 to 420 cSt (50 to 2000 sus); See Temperature and Oil Viscosity, page 9.060.1

Installation: No restrictions; See page 9.020.1

Cavity: VC08-2; See page 9.108.1

Cavity Tool: CT08-2XX; See page 8.600.1

Seal Kit: SK08-2X-T; See page 8.650.1

Coil Nut: Part No. 7004400;

For E-coils manufactured prior to 1-1-04, see page 3.400.1 for coil nut info.

SYMBOLS

USASI:

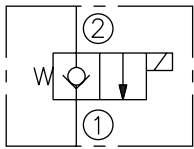

ISO:

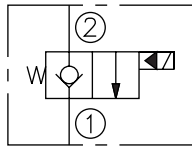

PERFORMANCE (Cartridge Only)

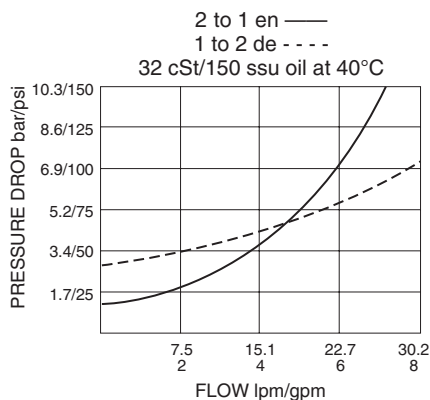

SV08-20

DIMENSIONS

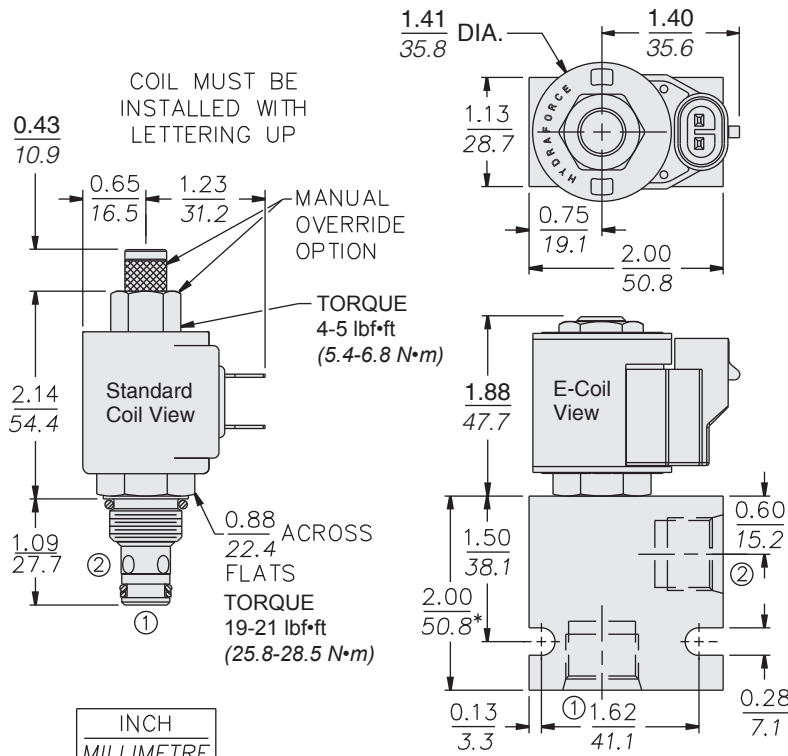

* BSP BODY - 55.9 mm

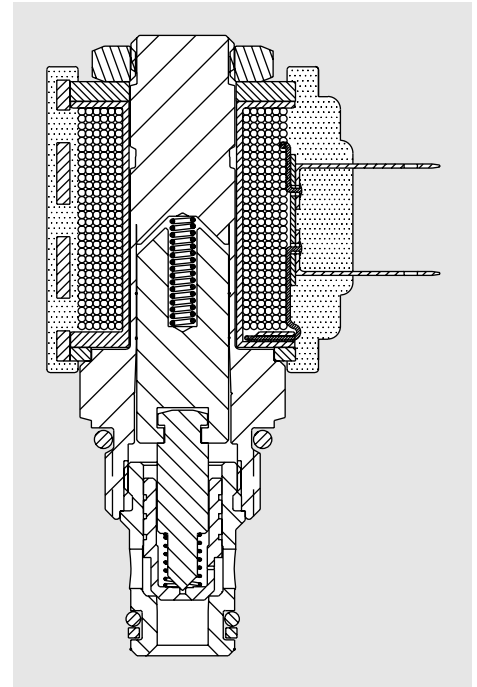

MATERIALS

Cartridge: Weight: 0.09 kg (0.20 lb); Steel with hardened work surfaces. Zinc-plated exposed surfaces; Buna N O-rings and back-ups standard.

Standard Ported Body: Weight: 0.16 kg (0.35 lb); Anodized high-strength 6061 T6 aluminum alloy, rated to 207 bar (3000 psi); Ductile iron bodies available; dimensions may differ. See page 8.008.1.

Standard Coil: Weight: 0.11 kg (0.25 lb); Unitized thermoplastic encapsulated, Class H high temperature magnet wire. See page 3.200.1.

E-Coil: Weight: 0.14 kg (0.3 lb); Perfect wound, fully encapsulated with rugged external metal shell; Rated up to IP69K with integral connectors.

Note: See page 3.400.1 for all E-Coil retrofit applications.

TO ORDER

SV08-20 - - - - -			
Option		Voltage Std. Coil	Termination (VDC) Std. Coil
None (Blank)		0 Less Coil**	DS Dual Spades
150µ Screen	S	10 10 Vdc†	DG DIN 43650
Manual Override	M	12 12 Vdc	DL Leadwires (2)
		24 24 Vdc	DL/W Leads w/Weatherpak® Connectors
Porting		36 36 Vdc	DR Deutsch DT04-2P
Cartridge Only	0	48 48 Vdc	Termination (VAC) Std. Coil
SAE 8	8T	24 24 Vac	AG DIN 43650
3/8 in. BSP*	3B	115 115 Vac	AP 1/2 in. Conduit
*BSP Body; U.K. Mfr. Only		230 230 Vac	Termination (VDC) E-Coil
		**Includes Std. Coil Nut	ER Deutsch DT04-2P (IP69K Rated)
		† DS, DW or DL terminations only.	EY Metri-Pack® 150 (IP69K Rated)
Seals		E-Coil	Coils with internal diode are available. Consult factory.
Buna N (Std.)	N	10 10 Vdc	
Fluorocarbon	V	12 12 Vdc	
		20 20 Vdc	
		24 24 Vdc	