

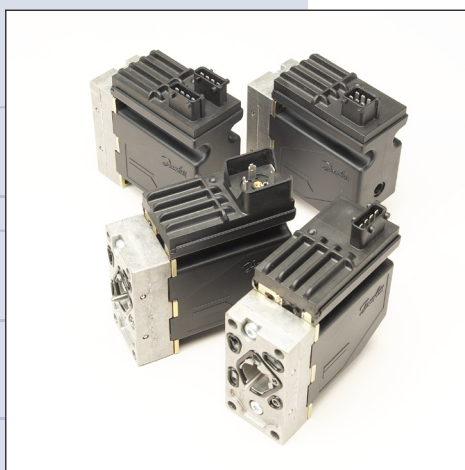

# PVE series 4 for PVG 32

## Technical Information

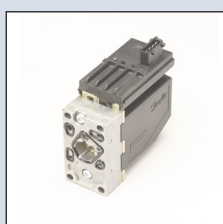
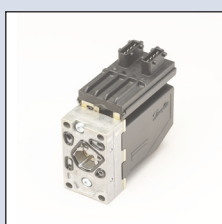

## CONTENTS

Contents - Introduction .....	2
Function.....	3
Electrical actuation .....	4
Technical data.....	8
Fault monitoring system.....	12
Dimensions.....	14
Connection and activation .....	15
Activation characteristic .....	16
Directional indicator .....	17
Examples of use .....	18
System safety .....	19
Code numbers .....	21

## INTRODUCTION

Product developments based on Sauer-Danfoss' activities in research and development, and design of new components is determined by market and customer requirements, thus contributing to maintaining and extending our leading market position in the field of electro hydraulically operated hydraulic valves.

The technology used in PVE series 4 is based on proven electronic development principles known from e.g. the automobile industry - together with our long experience within electrical activation of hydraulic valves for the mobile market. These factors will not only maintain the high level of quality and reliability experienced with PVE series 2 and 3, but will also give specification improvements for the PVE modules – e.g. the environmental protection.

This catalogue will give you an introduction to the different PVE modules, their functions and technical data.

© 2003 Sauer-Danfoss. All rights reserved. Printed in Europe

Sauer-Danfoss accepts no responsibility for possible errors in catalogs, brochures and other printed material. Sauer-Danfoss reserves the right to alter its products without prior notice. This also applies to products already ordered provided that such alterations aren't in conflict with agreed specifications. All trademarks in this material are properties of their respective owners. Sauer-Danfoss and the Sauer-Danfoss logotype are trademarks of the Sauer-Danfoss Group.

Front cover illustrations: F300700, F3007012, F300702, F300704  
drawing: 157-506

**FUNCTION**

The philosophy of Sauer-Danfoss electro hydraulic actuation, type PVE, is integration of electronics, sensors and actuators into a single unit that interfaces directly to the proportional valve body.

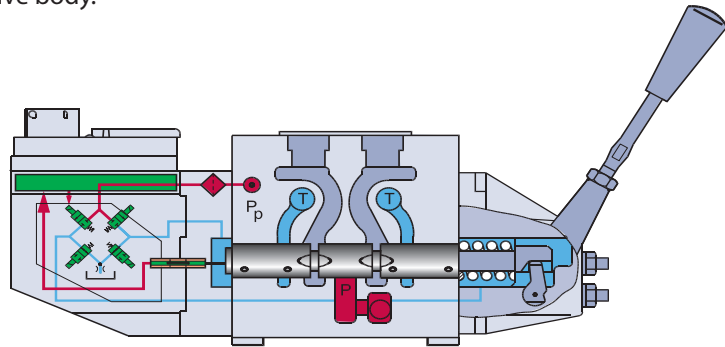

**Closed loop control**

All the proportional actuators feature an integrated feedback transducer that measures spool movement in relation to the input signal, and by means of a solenoid valve bridge, controls the direction, velocity and position of the main spool of the valve. The integrated electronics compensate for flow forces on the spool, internal leakage, changes in oil viscosity, pilot pressure, etc. This results in lower hysteresis and better resolution. Furthermore the electronics enable built in safety like fault monitoring, directional indication and LED light indication.

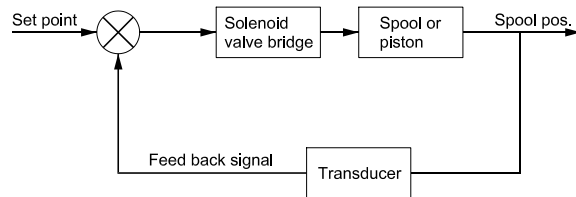

157-503.10

**Principle**

In principle the input signal (set-point signal) determines the level of pilot pressure which moves the main spool. The position of the main spool is sensed in the LVDT transducer which generates an electric feed-back signal registered by the electronics. The variation between the set-point signal and feed-back signal actuates the solenoid valves. The solenoid valves are actuated so that hydraulic pilot pressure drives the main spool into the correct position.

**Inductive transducer, LVDT**

(Linear Variable Differential Transformer). When the main spool is moved, a voltage is induced proportional to the spool position. The use of LVDT gives contact-free monitoring of the main spool position. This means an extra-long working life and no limitation as regards the type of hydraulic fluid used. In addition, LVDT gives a precise position signal of high resolution.

**Integrated pulse width modulation**

Positioning of the main spool in PVEA/PVEH/PVES is based on the pulse width modulation principle. As soon as the main spool reaches the required position, modulation stops and the spool is locked in position.

### ON/OFF ACTUATION

With electrical ON/OFF actuation the main spool is moved from neutral to maximum stroke when power is connected.

#### PVEO, ON/OFF

Main features of PVEO:

- Compact
- Robust operation
- With Hirschmann or AMP connector
- Low electrical power

#### PVEO-R, ON/OFF with hydraulic ramp

Like PVEO, but for applications where longer reaction time is needed.

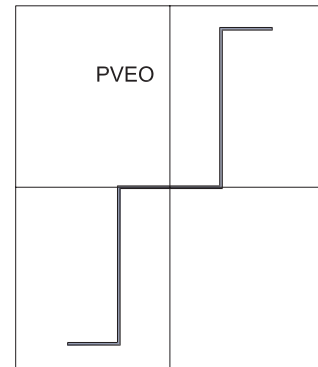

157-513.10

### PROPORTIONAL ACTUATION

With electrical proportional actuation the main spool position is adjusted so that it corresponds to an electrical signal – e.g. from a remote control unit.

#### PVEM, proportional medium

PVEM versions are recommended where there is a requirement for medium resolution proportional control and where reaction and hysteresis are not critical.

Main features of PVEM:

- ON-OFF modulated
- Inductive transducer
- Medium hysteresis
- With Hirschmann connector only
- Low electrical power
- No set-up procedure

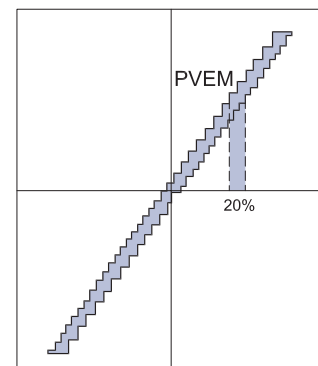

157-509.10

#### PVEA, proportional fine

PVEA versions are recommended where among the requirements are fault monitoring, low hysteresis, high resolution but where the reaction time is not critical.

Main features of PVEA:

- Inductive transducer
- Integrated pulse width modulation
- Low hysteresis
- AMP connector only
- As option with directional indicator (DI)
- Fault monitoring with transistor output for signal source.
- Low electrical power
- No set-up procedure

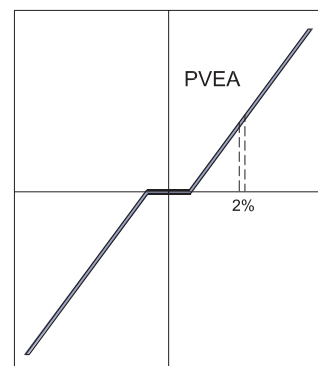

157-510.10

**PROPORTIONAL ACTUATION (CONTINUED)**

**PVEH, proportional high**

Performance like PVEA but with fast reaction time.  
 Main features of PVEH:

- Inductive transducer
- Integrated pulse width modulation
- Low hysteresis
- Fast reaction time
- Hirschmann or AMP connector
- As option with directional indicator (DI)
- Fault monitoring with transistor output for signal source
- Low electrical power
- No set-up procedure

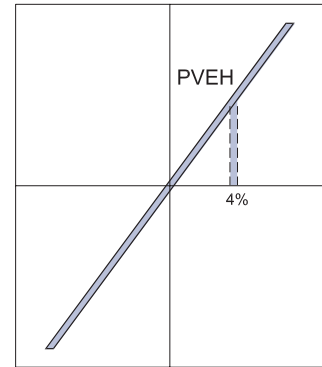

157-511.10

**PVES, proportional super**

PVES versions are recommended for control systems requiring very low hysteresis to obtain a high resolution.

For other technical data: see PVEH

- Hirschmann or AMP connector

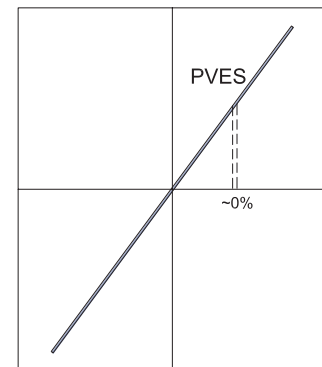

157-512.10

**HYDRAULIC PRINCIPLES**

**PVEO**

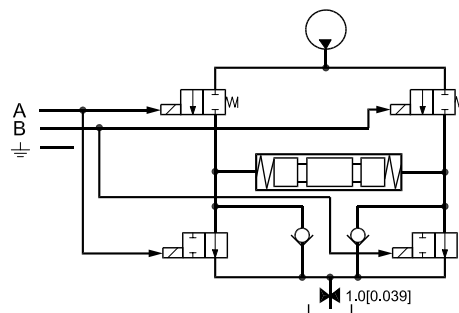

157-470.10

**PVEO-R**

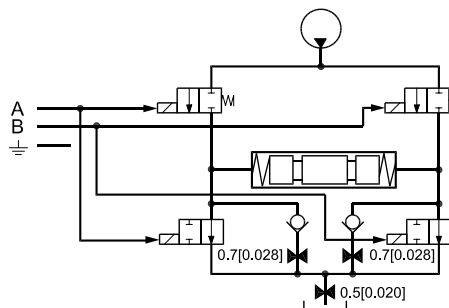

157-469.10

**HYDRAULIC PRINCIPLES  
 (CONTINUED)**

**PVEM**

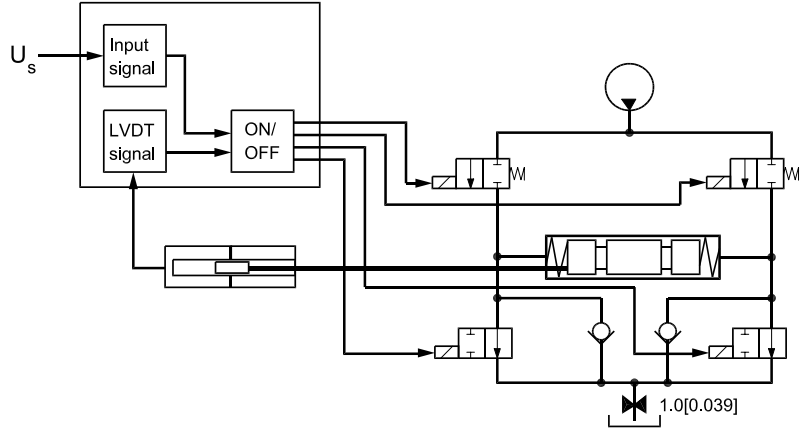

157-514.10

**PVEA**

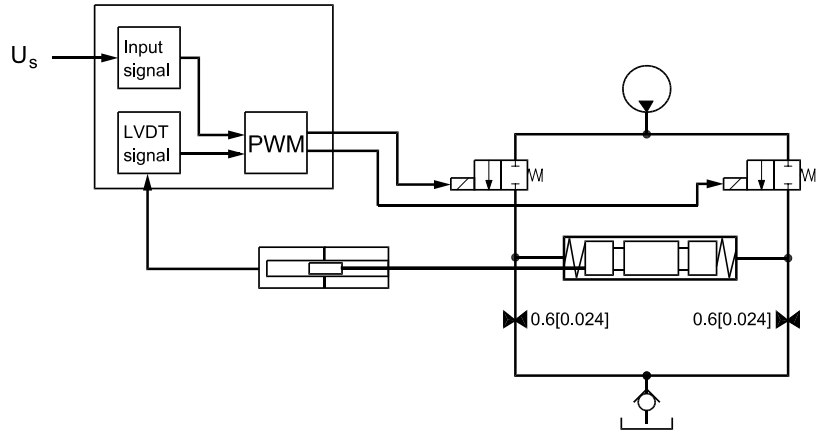

157-337.10

**PVEA-DI**

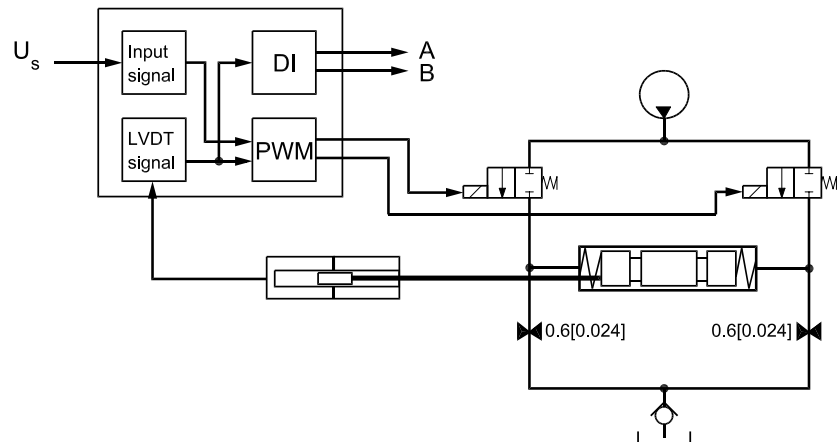

157-338.10

**HYDRAULIC PRINCIPLES**  
**(CONTINUED)**

**PVEH/PVES**

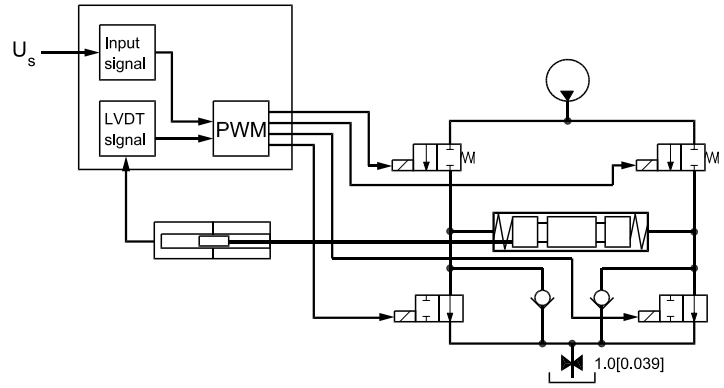

157-360.10

**PVEH-DI**

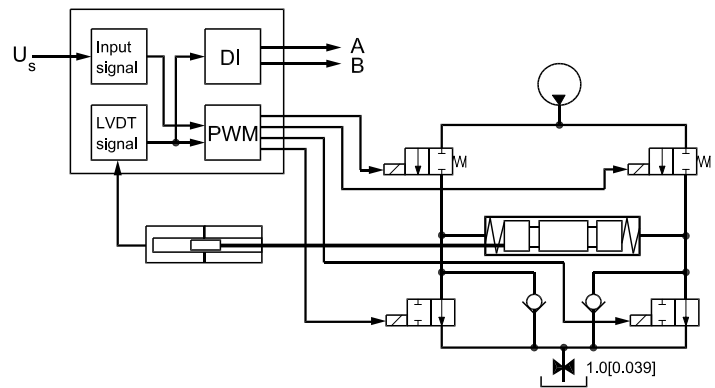

157-515.10

**TECHNICAL DATA**

The following technical data are from typical test results. For the hydraulic system a mineral based hydraulic oil with a viscosity of 21 mm<sup>2</sup>/s [102 SUS] and a temperature of 50° C [122° F] were used.

**PVEO and PVEM**

		PVEO and PVEM	
Supply voltage U <sub>DC</sub>	rated	12 V DC	24 V DC
	range	11 V to 15 V	22 V to 30 V
	max. ripple	5%	
Current consumption at rated voltage		0.65 A @ 12 V	0.33 A @ 24 V
Signal voltage (PVEM)	neutral	0.5 x U <sub>DC</sub>	
	A-port ↔ B-port	0.25 • U <sub>DC</sub> to 0.75 • U <sub>DC</sub>	
Signal current at rated voltage (PVEM)		0.25 mA	0.50 mA
Input impedance in relation to 0.5 • U <sub>DC</sub>		12 KΩ	
Power consumption		8 W	

**Reaction time PVEO and PVEM**

Supply voltage	Function		PVEO ON/OFF s	PVEO-R ON/OFF s	PVEM Prop. medium s
Disconnected by means of neutral switch	Reaction time from neutral position to max. spool travel	max.	0.235	0.410	0.700
		rated	0.180	0.350	0.450
		min.	0.120	0.250	0.230
Disconnected by means of neutral switch	Reaction time from max. spool travel to neutral position	max.	0.175	0.330	0.175
		rated	0.090	0.270	0.090
		min.	0.065	0.250	0.065
Constant voltage	Reaction time from neutral position to max. spool position	max.	-	-	0.700
		rated	-	-	0.450
		min.	-	-	0.230
Constant voltage	Reaction time from max. spool travel to neutral position	max.	-	-	0.700
		rated	-	-	0.450
		min.	-	-	0.230

Hysteresis <sup>1)</sup>	rated	-	-	20%
--------------------------	-------	---	---	-----

<sup>1)</sup>Hysteresis is indicated at rated voltage and f = 0.02 Hz for one cycle (one cycle = neutral -> full A -> full B -> neutral).



**TECHNICAL DATA**  
 (CONTINUED)

**PVEA, PVEH and PVES**

		PVEA, PVEH and PVES	
Supply voltage $U_{DC}$	rated	11 V to 32 V	
	range	11 V to 32 V	
	max. ripple	5%	
Current consumption at rated voltage	PVEH/PVES (PVEA)	0.57 (0.28) A @ 12 V	0.3 (0.15) A @ 24 V
Signal voltage	neutral	$0.5 \times U_{DC}$	
	A-port ↔ B-port	$0.25 \cdot U_{DC}$ to $0.75 \cdot U_{DC}$	
Signal current at rated voltage		0.25 mA to 0.70 mA	
Input impedance in relation to $0.5 \cdot U_{DC}$		12 KΩ	
Input capacitor		100 nF	
Power consumption	PVEH/PVES (PVEA)	7 (3.5) W	

**Reaction time**

Supply voltage	Function		PVEA Prop. fine s	PVEH Prop. high s	PVES Prop. super s
Disconnected by means of neutral switch	Reaction time from neutral position to max. spool travel	max.	0.500	0.230	0.230
		rated	0.320	0.150	0.150
		min.	0.250	0.120	0.120
Disconnected by means of neutral switch	Reaction time from max. spool travel to neutral position	max.	0.550	0.175	0.175
		rated	0.400	0.090	0.090
		min.	0.300	0.065	0.065
Constant voltage	Reaction time from neutral position to max. spool travel	max.	0.500	0.200	0.200
		rated	0.320	0.120	0.120
		min.	0.250	0.050	0.050
Constant voltage	Reaction time from max. spool travel to neutral position	max.	0.250	0.100	0.100
		rated	0.200	0.090	0.090
		min.	0.150	0.065	0.065

Hysteresis <sup>1)</sup>	rated	2%	4%	~ 0%
--------------------------	-------	----	----	------

<sup>1)</sup>Hysteresis is indicated at rated voltage and  $f = 0.02$  Hz for one cycle (one cycle = neutral -> full A -> full B -> neutral).

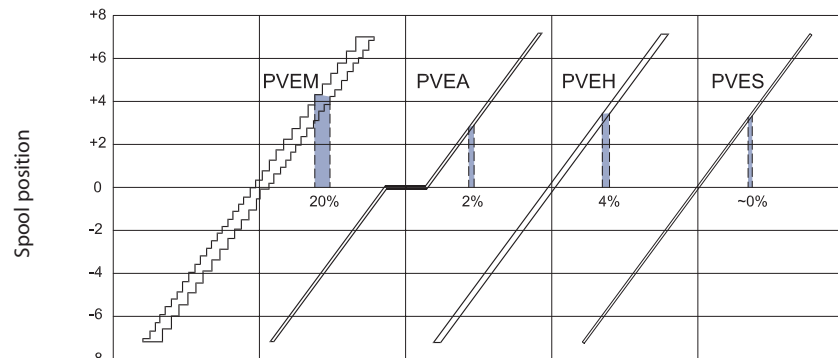

**TECHNICAL DATA  
 (CONTINUED)**

**Oil consumption PVEO and PVEM**

Supply voltage	Function	PVEO ON/OFF	PVEM Prop. medium
Without voltage	Pilot oil flow per PVE neutral	0 l/min [0 US gal/min]	0 l/min [0 US gal/min]
With voltage	locked	0.1 l/min [0.026 US gal/min]	0.1 l/min [0.026 US gal/min]
	one actuation (neutral → max.)	0.002 l [0.053 US gal]	0.002 l [0.053 US gal]
	continuous actuations	0.7 l/min [0.185 US gal/min]	0.5 l/min [0.132 US gal/min]

**Oil consumption PVEA, PVEH and PVES**

Supply voltage	Function	PVEA Prop. fine	PVEH Prop. high	PVES Prop. super
Without voltage	Pilot oil flow per PVE neutral	0 l/min [0 US gal/min]	0 l/min [0 US gal/min]	4 l/min [0.106 US gal/min]
With voltage	locked	0.5 l/min [0.132 US gal/min]	0.1 l/min [0.026 US gal/min]	0.2 l/min [0.053 US gal/min]
	one actuation (neutral → max.)	0.002 l [0.053 US gal]	0.002 l [0.053 US gal]	0.002 l [0.053 US gal]
	continuous actuations	0.75 l/min [0.200 US gal/min]	1.1 l/min [0.290 US gal/min]	1.1 l/min [0.290 US gal/min]

**Oil viscosity**

Oil viscosity	range	12 - 75 mm <sup>2</sup> /s [65 - 347 SUS]
	min.	4 mm <sup>2</sup> /s [39 SUS]
	max.	460 mm <sup>2</sup> /s [2128 SUS]

Note: Max. start up viscosity 2500 mm<sup>2</sup>/s

**Oil temperature**

Oil - temperature	range	30 - 60 °C [86 - 140 °F]
	min.	-30 °C [-22 °F]
	max.	90 °C [194 °F]

**Filtering**

Filtering in the hydraulic system	Max. allowed degree of contamination (ISO 4406, 1999 version): 18/16/13
-----------------------------------	---

**TECHNICAL DATA  
 (CONTINUED)**

**Pilot pressure**

Pilot pressure (relative to T pressure)	nom.	13.5 bar [196 psi]
	min.	10 bar [145 psi]
	max.	15 bar [217 psi]

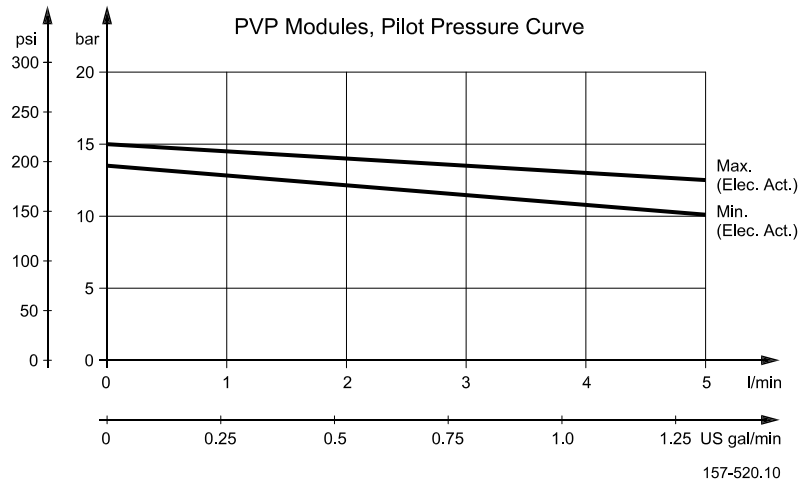

**Enclosure and connector**

Version with Hirschmann connector	
Grade of enclosure *	IP 65

Version with AMP JPT connector	
Grade of enclosure *	IP 66

\* According to the international standard IEC 529  
 NB: In particularly exposed applications, protection in the form of screening is recommended.

## THE FAULT MONITORING SYSTEM

A fault monitoring system is provided in all PVEA, PVEH and PVES modules. The system is available in two versions:

- The active fault monitoring type, which provides a warning signal, deactivates the solenoid valves and drives the spool in neutral.
- The passive fault monitoring type, which provides a warning signal only.

Both active and passive fault monitoring systems are triggered by three main events:

### 1. Input signal monitoring

The input signal voltage is continuously monitored. The permissible range is between 15% and 85% of the supply voltage. Outside this range the section will switch into an active error state.

### 2. Transducer supervision

If one of the wires to the LVDT sensor is broken or short-circuited, the section will switch into an active error state.

### 3. Supervision of the closed loop

The actual position must always correspond to the demanded position (input signal). If the actual spool position is further than the demanded spool position (>12%, PVEA: >25%), the system detects an error and will switch into an active error state.

On the other hand, a situation where the actual position is closer to neutral than that demanded will not cause an error state. This situation is considered "in control".

When an active error state occurs, the fault monitoring logic will be triggered:

### Active fault monitoring

- A delay of 500 ms (PVEA: 750 ms) before anything happens.
- The solenoid valve bridge will be disabled and all solenoid valves will be released.
- An alarm signal is sent out through the appropriate pin connection.
- This state is memorized and continues until the system is actively reset (by turning off the supply voltage).

### Passive fault monitoring

- A delay of 250 ms (PVEA: 750 ms) before anything happens.
- The solenoid valve bridge will not be disabled but still control the main spool position.
- An alarm signal is sent out through the appropriate pin connection.
- This state is not memorized. When the erroneous state disappears, the alarm signal will turn to passive again. However, the signal will always be active for a minimum of 100 ms when triggered.

To prevent the electronics from going into an undefined state, a general supervision of the power supply and the internal clock frequency is made. This function applies to PVEA, PVEH and PVES - and will not activate fault monitoring:

#### 1. High supply voltage

The solenoid valves are disabled when the supply voltage exceeds 36 V, and the main spool will return/stay in neutral.

#### 2. Low supply voltage:

The solenoid valves are disabled when the supply voltage falls below 8.5 V, and the main spool will return/stay in neutral.

**THE FAULT MONITORING SYSTEM (CONTINUED)**

**3. Internal clock**

The solenoid valves are disabled when the internal clock frequency fails, and the main spool will return/stay in neutral.

**▲ WARNING**

It's up to the customer to decide on the required degree of safety for the system (see page 19).

**FAULT MONITORING OVERVIEW**

Type	Fault monitoring	Delay before error out	Error mode	Error output status	Fault output on PVE <sup>1)</sup>	LED light	Memory (reset needed)
PVEO PVEM	No fault monitoring	-	-	-	-	-	-
PVEA PVEH PVES	Active	500 ms (PVEA: 750ms)	No fault	Low	< 2 V	Green	-
			Input signal faults	High	~U <sub>DC</sub>	Flashing red	Yes
			Transducer (LVDT)			Constant red	
	Close loop fault						
	Passive	250 ms (PVEA: 750ms)	No fault	Low	< 2 V	Green	-
			Input signal faults	High	~U <sub>DC</sub>	Flashing red	No
Transducer (LVDT)			Constant red				
Close loop fault							

<sup>1)</sup> Measured between fault output pin and ground

**GENERAL DIMENSIONS**

**PVE with Hirschmann connector**

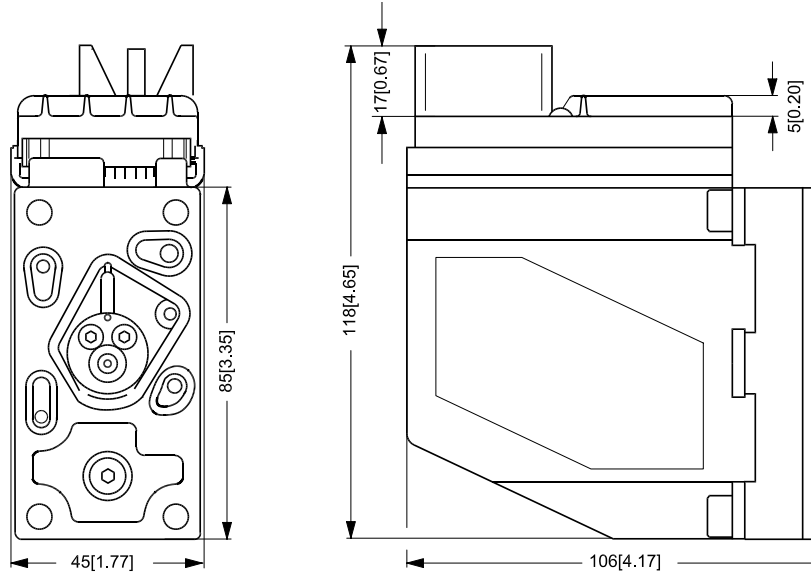

**PVE with AMP connector**

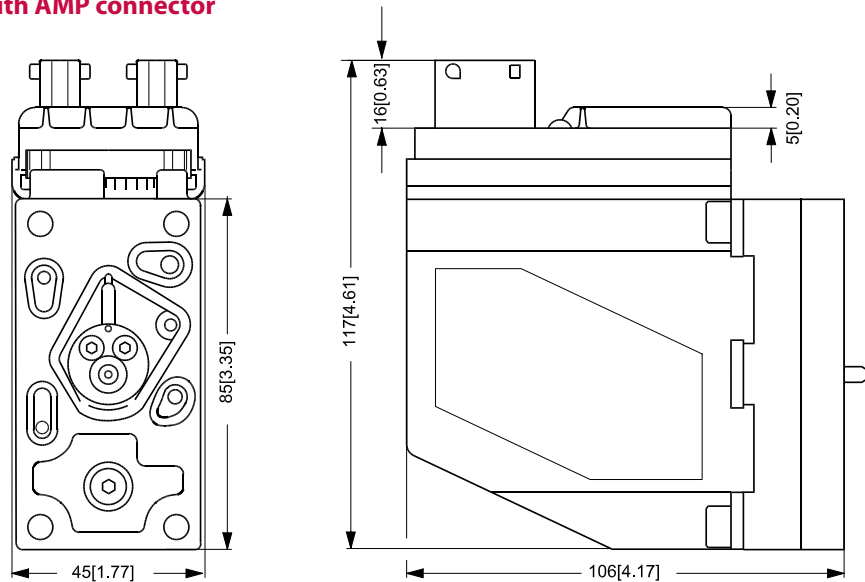

**AMP-VERSION ON/OFF**

Function	Signal voltage (A or B)	
	A (pin 1)	B (pin 2)
Neutral	0	0
Q: P -> A	$U_{DC}$	0
Q: P -> B	0	$U_{DC}$

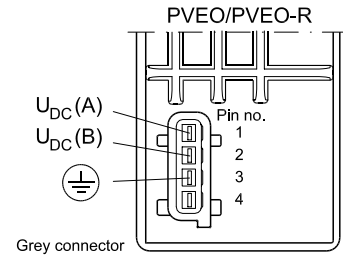

157-498.10

**AMP-VERSION PROPORTIONAL**

Function	Signal voltage ( $U_s$ )
Neutral	$U_s$ (pin 1) = $0.5 \cdot U_{DC}$
Q: P -> A	$U_s$ (pin 1) = $(0.5 \rightarrow 0.25) \cdot U_{DC}$
Q: P -> B	$U_s$ (pin 1) = $(0.5 \rightarrow 0.75) \cdot U_{DC}$

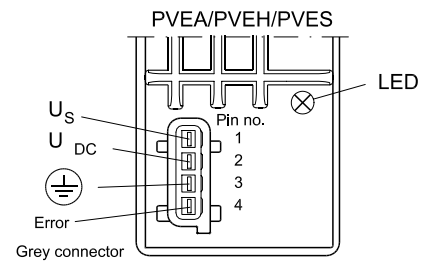

157-500.10

On DI versions two  $U_{DC}$  connections ( $U_{DC1}$  and  $U_{DC2}$ ) are necessary.

- $U_{DC1}$  will supply the solenoid valves
- $U_{DC2}$  will supply the electronics

The two ground pins (pin 3) are internally connected.

With advantages two separate power supplies can be used, see also system safety page 19.

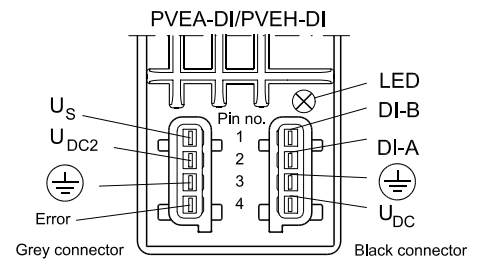

157-499.10

**HIRSCHMANN-VERSION ON/OFF**

Function	Signal voltage (A or B)	
	A (pin 1)	B (pin 2)
Neutral	0	0
Q: P -> A	$U_{DC}$	0
Q: P -> B	0	$U_{DC}$

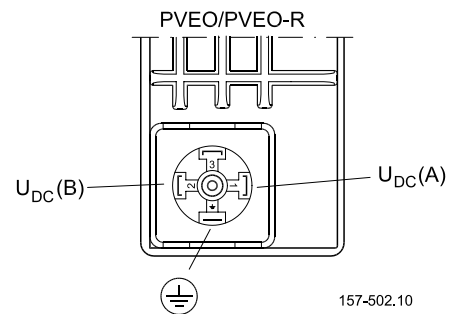

157-502.10

**HIRSCHMANN-VERSION PROPORTIONAL**

Function	Signal voltage ( $U_s$ )
Neutral	$U_s$ (pin 2) = $0.5 \cdot U_{DC}$
Q: P -> A	$U_s$ (pin 2) = $(0.5 \rightarrow 0.25) \cdot U_{DC}$
Q: P -> B	$U_s$ (pin 2) = $(0.5 \rightarrow 0.75) \cdot U_{DC}$

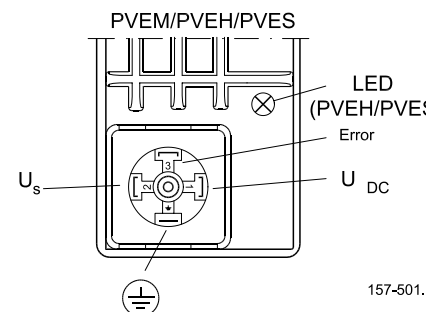

157-501.

**STANDARD MAIN SPOOLS**

**Characteristics; oil flow, spool travel and voltage**

The spools have 7 mm spool travel in direction A and 7 mm travel in direction B:

- 7 mm [0.27 in] spool displacement in direction A gives max. oil flow to port A
- 7 mm [0.27 in] spool displacement in direction B gives max. oil flow to port B

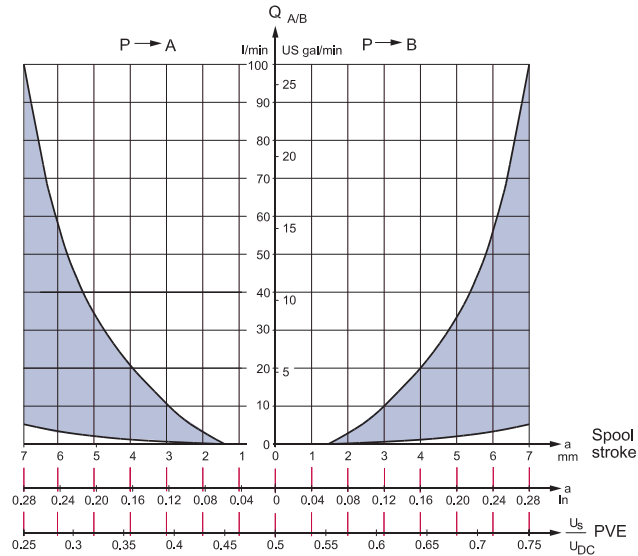

157-505.10

**FLOAT SPOOLS**

**Characteristics; oil flow, spool travel and voltage**

The spools have 4,8 mm spool travel in direction A and 8 mm travel in direction B:

- 4.8 mm [0.19 in] spool displacement in direction A gives max. oil flow to port A
- 4.8 mm [0.19 in] spool displacement in direction B gives max. oil flow to port B
- 8 mm [0.32 in] spool displacement in direction B gives completely open float position A/B → T.

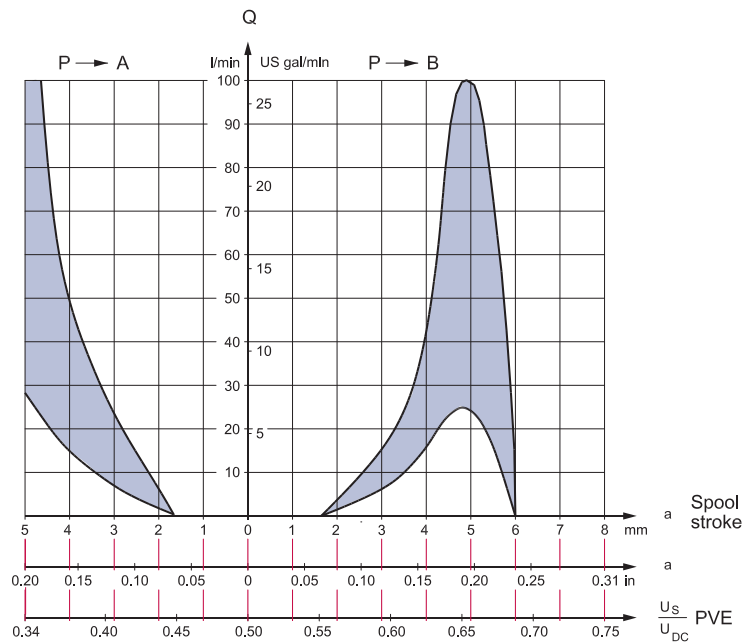

157-507.11



**DIRECTION INDICATOR**

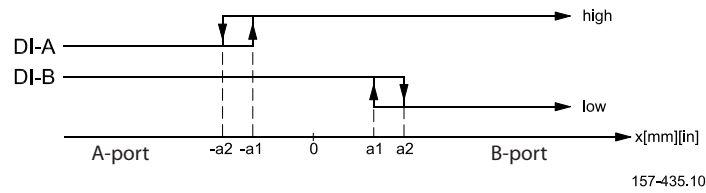

157-435.10

	A-port	B-port
Direction signals "a1", "a2"	$-0.8 \pm 0.4 \text{ mm}$ [ $0.031 \pm 0.015 \text{ in}$ ]	$0.8 \pm 0.4 \text{ mm}$ [ $0.031 \pm 0.015 \text{ in}$ ]
Max. load of "Dir_A", "Dir_B"	50 mA	
Voltage "High" value with load of "Dir_A" or "Dir_B" = 20 mA	Minimum. $U_{DC} - 1.5 \text{ V}$	
Voltage "High" value with load of "Dir_A" or "Dir_B" = 50 mA	Minimum. $U_{DC} - 2.0 \text{ V}$	

**EXAMPLES OF USE**

Signal wires must not be used to connect the power supply unless the distance between PVE and terminal board is < 3 m [120 in] and the wire cross-section is  $\geq 0.75 \text{ mm}^2$  [0.001 in<sup>2</sup>].

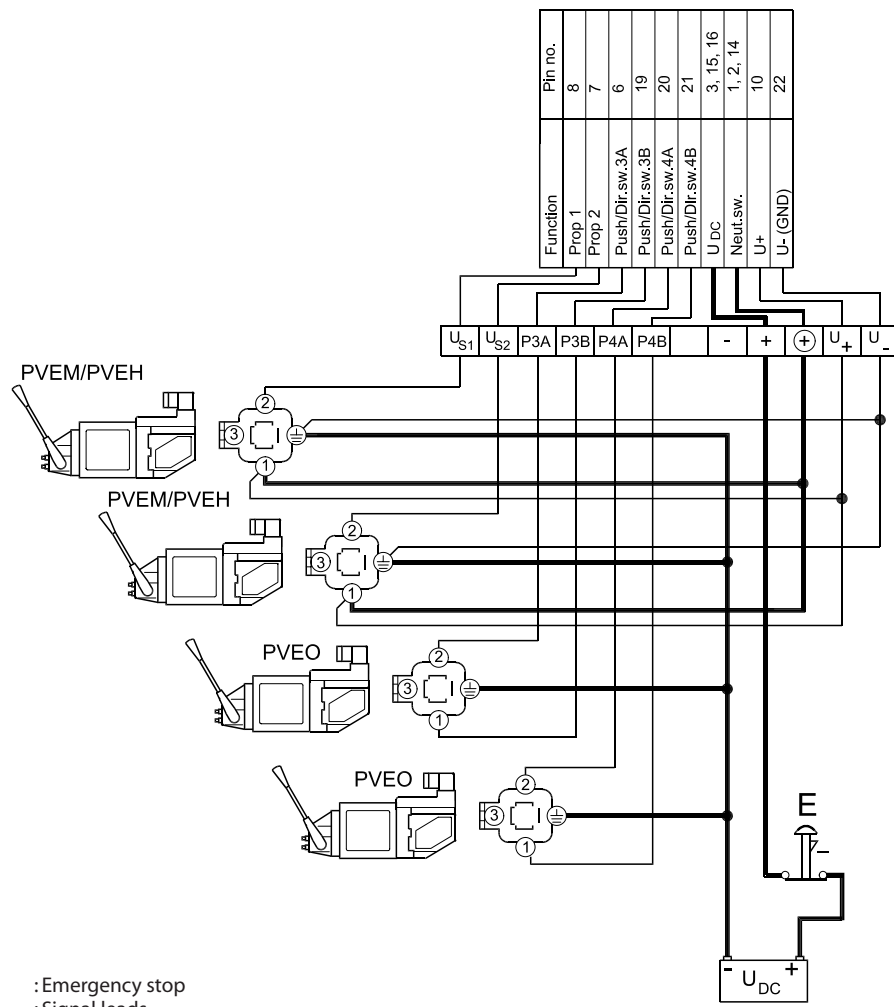
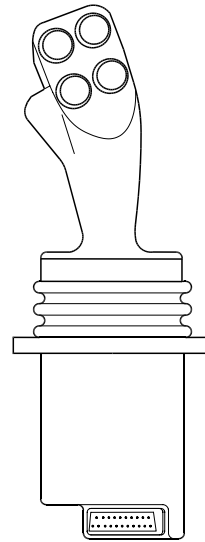

E : Emergency stop  
 — : Signal leads  
 — : Supply leads

162B60.11

**▲ WARNING**

All marks and all types of directional control valves – inclusive proportional valves – can fail and cause serious damage. It is therefore important to analyse all aspects of the application.

Because the proportional valves are used in many different operation conditions and applications, the manufacturer of the application is alone responsible for making the final selection of the products – and assuring that all performance, safety and warning requirements of the application are met.

The process of choosing the control system – and safety level – could e.g. be governed by EN 954-1 (Safety related parts of control system).

**BUILDING IN SAFETY**

Example 1:

Proposal for a system with continuous monitoring and detection:

- PVE with DI function (Direction Indicator) and active fault monitoring
- 2 separate power supplies – one for the PVE function and one for the DI function
  - make it possible to interrupt the PVE function without losing the DI function. E.g. the machine operator can activate the emergency stop device and stop the function
  - but still have the DI signal active for the overall safety system (e.g. a controller).
- The overall safety system (e.g. a controller) uses the fault indication from the DI function or the fault monitoring to interrupt the valve function (e.g. dump the pump flow).

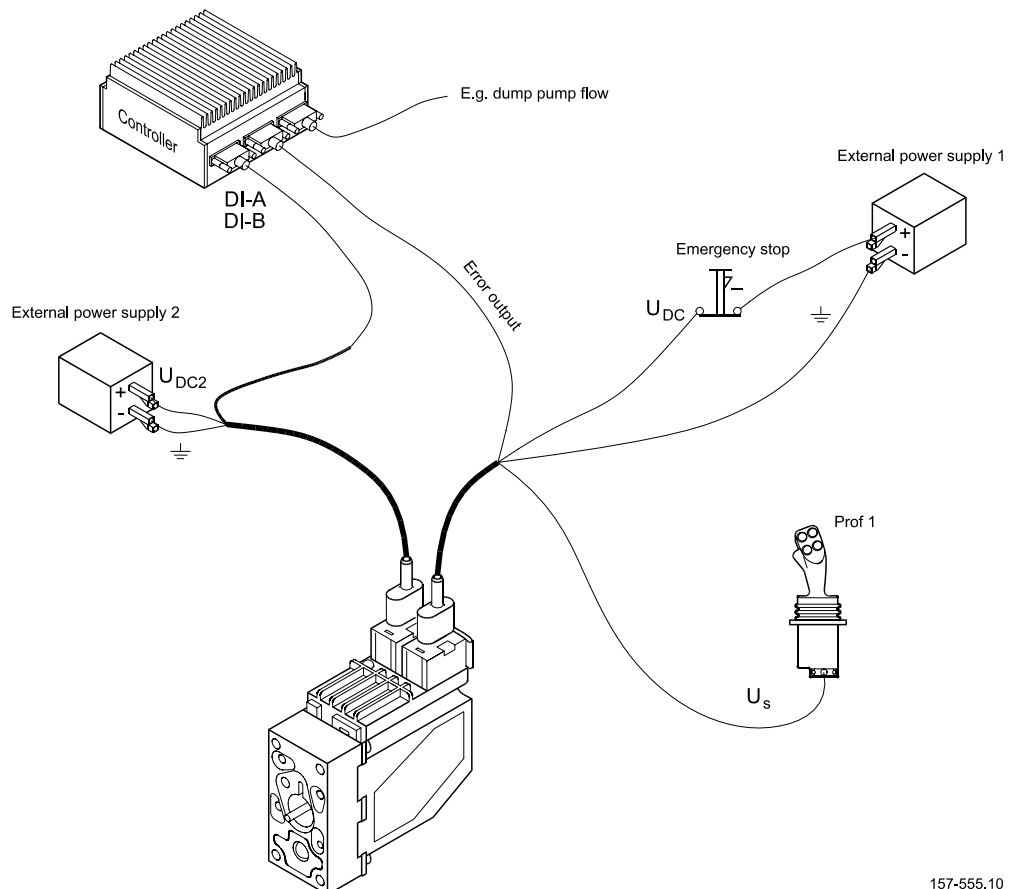

**EXAMPLE (CONTINUED)**

Example 2:

Proposal for a system with fault monitoring and detection:

- PVE with active fault monitoring
- The fault monitoring can be used to interrupt the valve function (e.g. dump the pump flow).
- Activation of the emergency stop device will stop the function – but also disconnect the fault monitoring system.

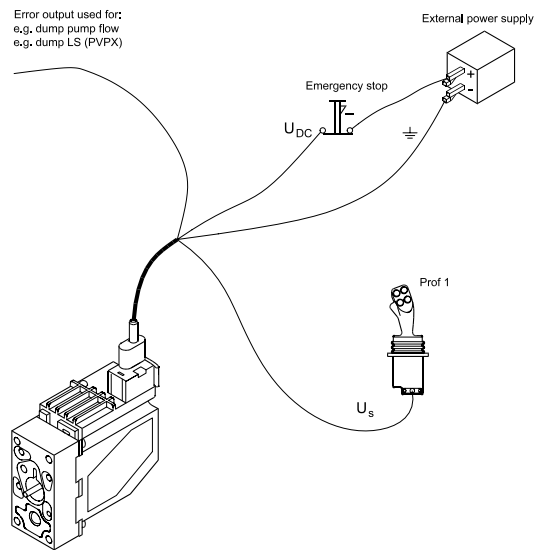

157-557.10

Example 3:

Simple system without fault monitoring and detection:

- PVEO or PVEM
- Activation of the emergency stop device will stop the function

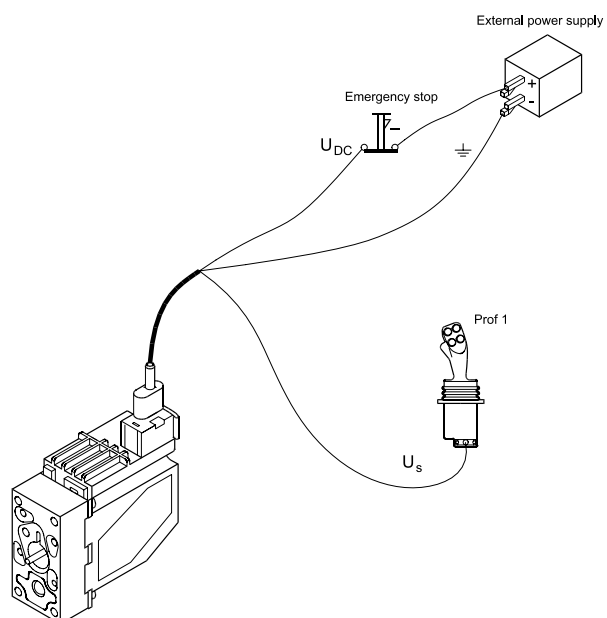

157-556.10

**CODE NUMBERS FOR  
 USE ON PVG 32  
 157B....**

**PVE for PVG 32**

PVEO, ON/OFF actuation Code no. 157B....		Hirschmann connector		AMP connector	
		12 V	24 V	12 V	24 V
PVEO	ON/OFF	4216	4228	4901	4902
	ON/OFF with ramp	4217	4229	4903	4904

PVEM, proportional actuation Code no. 157B....		Hirschmann connector	
		12 V	24 V
PVEM	Standard	4116	4128
	Float	4416	4428

PVEA/PVEH/PVES, proportional actuation Code no. 157B....		Hirschmann connector	AMP connector
		11 - 32 V	11 - 32 V
PVEA	Standard, active fault monitoring	Not available	4734
	Standard, passive fault monitoring	Not available	4735
PVEA-DI	Standard, active fault monitoring	Not available	4736
	Standard, passive fault monitoring	Not available	4737
PVEH	Standard, active fault monitoring	4032	4034
	Standard, passive fault monitoring	4033	4035
	Float, active fault monitoring	4332	Not available
PVEH-DI	Standard, active fault monitoring	Not available	4036
	Standard, passive fault monitoring	Not available	4037
PVES	0% hysteresis, active fault monitoring	4832	4834
	0% hysteresis, passive fault monitoring	4833	4835



PVE series 4 for PVG 32  
Technical Information  
Notes

NOTES



PVE series 4 for PVG 32  
Technical Information  
Notes

**NOTES**



## OUR PRODUCTS

Hydrostatic transmissions  
Hydraulic power steering  
Electro-hydraulic power steering  
Electric power steering  
Closed and open circuit axial piston  
Pumps and motors  
Gear pumps and motors  
Bent axis motors  
Orbital motors  
Transit mixer drives  
Planetary compact gears  
Proportional valves  
Directional spool valves  
Cartridge valves  
Hydraulic integrated circuits  
Hydrostatic transaxles  
Integrated systems  
Fan drive systems  
Electrohydraulic controls  
Digital electronics and software  
Electric motors and inverters  
Sensors

## Sauer-Danfoss Hydraulic Power Systems – Market Leaders Worldwide

Sauer-Danfoss is a comprehensive supplier providing complete systems to the global mobile market.

Sauer-Danfoss serves markets such as agriculture, construction, road building, material handling, municipal, forestry, turf care, and many others.

We offer our customers optimum solutions for their needs and develop new products and systems in close cooperation and partnership with them.

Sauer-Danfoss specializes in integrating a full range of system components to provide vehicle designers with the most advanced total system design.

Sauer-Danfoss provides comprehensive worldwide service for its products through an extensive network of Authorized Service Centers strategically located in all parts of the world.

Sauer-Danfoss (US) Company  
2800 East 13th Street  
Ames, IA 50010, USA  
Phone: +1 515 239-6000, Fax: +1 515 239 6618

Sauer-Danfoss (Neumünster) GmbH & Co. OHG  
Postfach 2460, D-24531 Neumünster  
Krokamp 35, D-24539 Neumünster, Germany  
Phone: +49 4321 871-0, Fax: +49 4321 871 122

Sauer-Danfoss (Nordborg) A/S  
DK-6430 Nordborg, Denmark  
Phone: +45 7488 4444, Fax: +45 7488 4400