

HOW TO ORDER - SINGLE UNITS

KP30.73	S	0	83	E3	L	ED/EB	N	-	-	-	
1	2	3	4	5	6	7	8	9	10	11	12
KP 30•27	R	0	04	S3	L	OF/OD	N	0A	C4	CSC	VNR01

1	Type	Pump type	Motor type
	21,99 cm ³ /rev (1.34 in ³ /rev)	KP 30•22	KM 30•22
	26,7 cm ³ /rev (1.63 in ³ /rev)	KP 30•27	KM 30•27
	30,63 cm ³ /rev (1.87 in ³ /rev)	KP 30•31	KM 30•31
	34,56 cm ³ /rev (2.11 in ³ /rev)	KP 30•34	KM 30•34
	39,27 cm ³ /rev (2.40 in ³ /rev)	KP 30•38	KM 30•38
	41,62 cm ³ /rev (2.54 in ³ /rev)	KP 30•41	KM 30•41
	43,98 cm ³ /rev (2.68 in ³ /rev)	KP 30•43	KM 30•43
	46,34 cm ³ /rev (2.83 in ³ /rev)	KP 30•46	KM 30•46
	51,83 cm ³ /rev (3.16 in ³ /rev)	KP 30•51	KM 30•51
	56,54 cm ³ /rev (3.45 in ³ /rev)	KP 30•56	KM 30•56
	61,26 cm ³ /rev (3.74 in ³ /rev)	KP 30•61	KM 30•61
	73,82 cm³/rev (4.50 in³/rev)	KP 30•73	KM 30•73

2	Rotation	Code
	Anti-clockwise	S
	Clockwise	D
	Reversible rear external drain	R
	Reversible side external drain	L
	Reversible internal drain	B

3	Outboard bearing options	Code
	Without outboard bearing	0
	With outboard bearing	1
	With outboard bearing	3
	With outboard bearing	6

4	Drive shaft	Code
	European tapered 1:8	83
	SAE "B" spline (13 teeth)	04
	SAE "B" straight	32
	SAE "BB" spline (15 teeth)	05
	SAE "BB" straight	33
	SAE "B" spline (13 teeth) for K9	A8
	SAE "BB" spline (15 teeth) for K9	A5
	SAE "C" spline (14 teeth)	06
	SAE "C" spline short type (14 teeth)	A6

Code	Mounting flange	5
E3	European	
S1	SAE "A" 2 holes	
S2	SAE "A" 2 holes with O-ring	
S9	SAE "A" 2 holes short type	
S3	SAE "B" 2-4 holes	
K9	SAE "B" 2 holes	
S6	SAE "C" 4 holes	
S8	SAE "C" 2 holes	
Q3	SAE "C" 2 holes short type	

Code	Ports position	6
L	IN/OUT side	
H	IN side/ OUT rear	
K	IN rear/ OUT side	
P	IN/OUT rear	

Code	Ports IN/OUT	7
EUROPEAN FLANGED PORTS		
Side	Rear	Type
ED/EB	KP 30	22-27-31-34-38
EB/ED	KM 30	41-43-46-51-56-61
EF/ED	KP 30	
ED/EF	KM 30	73
SAE FLANGED PORTS (SSM)		
Side	Rear	Type
MC/MB	KP 30	22-27-31-34-38
MB/MC	KM 30	
MD/MC	KP 30	41-43-46-51
MC/MD	KM 30	
ME/MD	KP 30	56-61-73
MD/ME	KM 30	
SAE FLANGED PORTS (SSS)		
Side	Rear	Type
SC/SB	KP 30	22-27-31-34-38
SB/SC	KM 30	
SD/SC	KP 30	41-43-46-51
SC/SD	KM 30	
SE/SD	KP 30	56-61-73
SD/SE	KM 30	

01/10.2018

OUTBOARD BEARING OPTIONS

For each version, the possible combination between drive shafts and mounting flanges are shown on pages 40 ÷ 44.

0

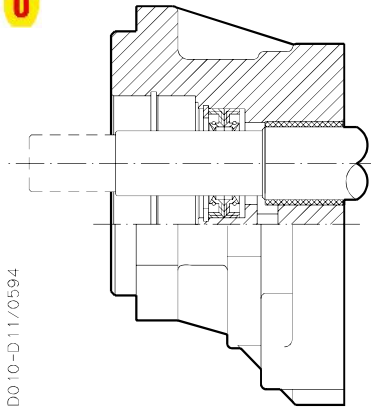

Version for applications without radial and axial load on the drive shaft.

1

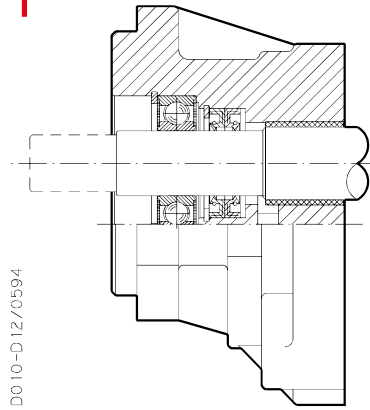

Version for applications with low radial load and without axial load on the drive shaft.

3

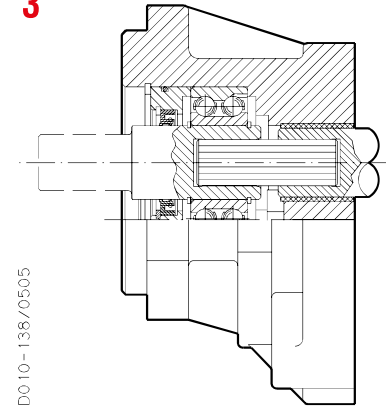

Version for applications with radial and axial load on the drive shaft

Max. torque version 3:
KAPPA 30: 170 Nm (1505 lbf in)

6

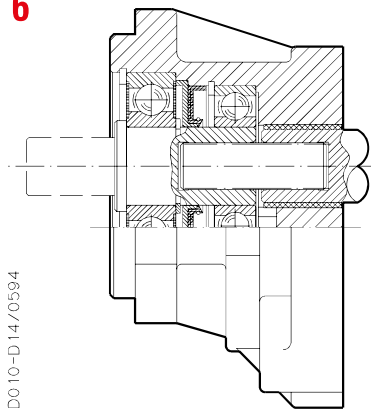

Version for applications with radial and low axial load on the drive shaft.

Max. torque version 6:
KAPPA 30: 170 Nm (1505 lbf in)

01/10.2018

For the outboard bearings life expectancy, diagrams providing approximate selection data will be found on subsequent pages. For particular applications please consult our pre-sales department.

KAPPA 30

DRIVE SHAFTS

SAE "C" SPLINE

06

Not available with size: **30•41**

Mounting face refer to flange code **S8**

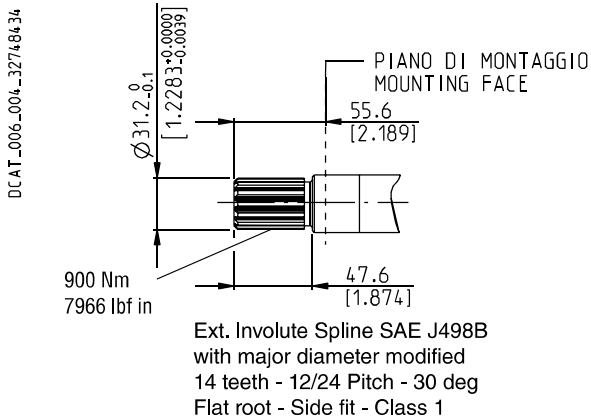

EUROPEAN TAPERED

83

Not available with size: **30•41**

Mounting face refer to flange code **E3**

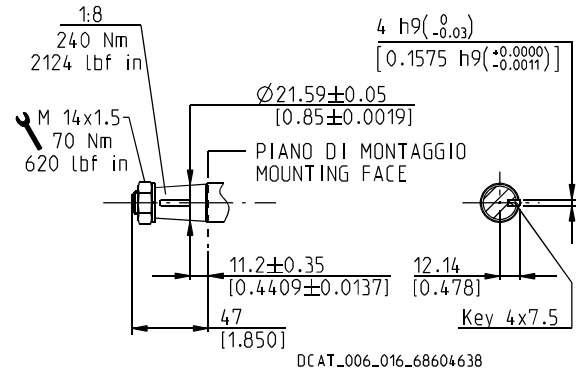

SAE "C" SPLINE - SHORT TYPE

A6

Not available with size: **30•22 - 30•31 - 30•46 - 30•56 - 30•73**

Mounting face refer to flange code **Q3**

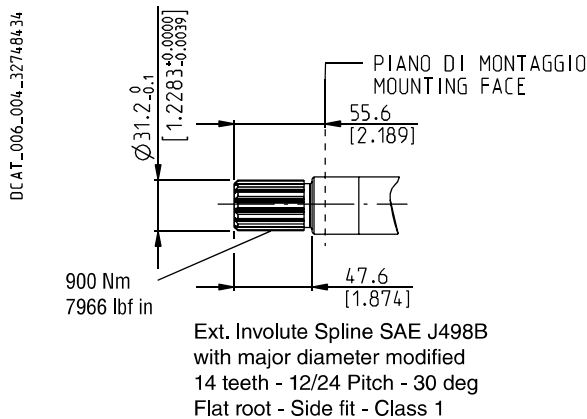

01/10.2018

KAPPA 30 MOUNTING FLANGES AND TABLE OF COMPATIBILITY

EUROPEAN

E3

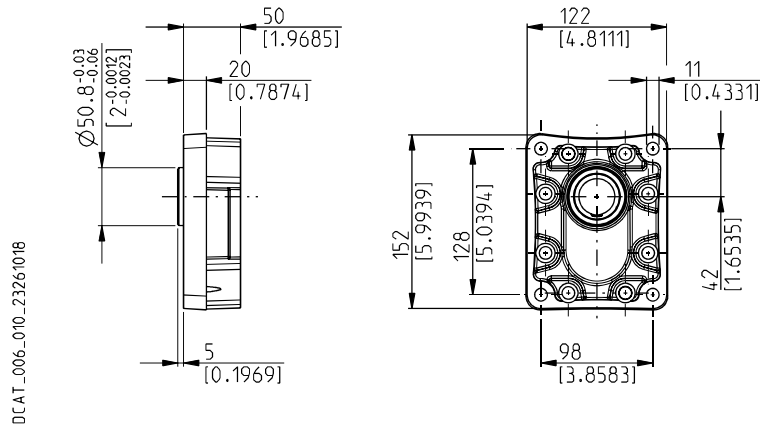

DCAT_006_010_2326*018

DRIVE SHAFTS
See page 38 and 39

VERSIONS
See page 35

0

83



A8



A5



- Standard combination
- Available combination

PORTS POSITION AND TYPE

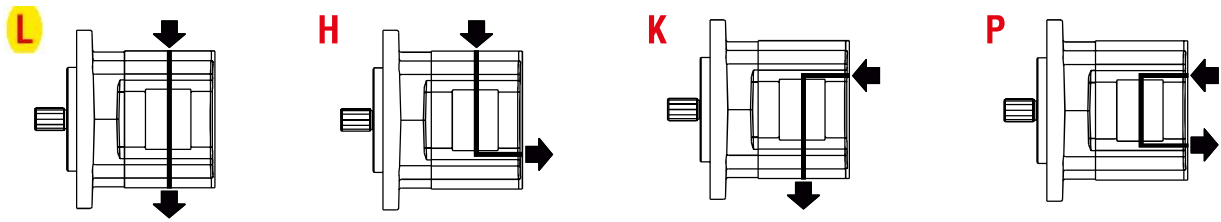

PORTS TYPE	SIDE PORTS												REAR PORTS			
	European		Split SSM		Spit SSS		Gas BSPP		SAE ODT		German		Gas BSPP		SAE ODT	
Pump type	IN	OUT	IN	OUT	IN	OUT	IN	OUT	IN	OUT	IN	OUT	IN	OUT	IN	OUT
Motor type	OUT	IN	OUT	IN	OUT	IN	OUT	IN	OUT	IN	OUT	IN	OUT	IN	OUT	IN
K. 30•22	ED	EB	MC	MB	SC	SB	GF	GE	OF	OD	BM	BL	GF	GE	OF	OD
K. 30•27	ED	EB	MC	MB	SC	SB	GF	GE	OF	OD	BM	BL	GF	GE	OF	OD
K. 30•31	ED	EB	MC	MB	SC	SB	GF	GE	OF	OD	BM	BL	GF	GE	OF	OD
K. 30•34	ED	EB	MC	MB	SC	SB	GF	GE	OF	OD	BM	BL	GF	GE	OF	OD
K. 30•38	ED	EB	MC	MB	SC	SB	GF	GE	OF	OD	BM	BL	GF	GE	OF	OD
K. 30•41	ED	EB	MD	MC	SD	SC	GG	GF	OG	OF	BM	BL	GG	GF	OG	OF
K. 30•43	ED	EB	MD	MC	SD	SC	GG	GF	OG	OF	BM	BL	GG	GF	OG	OF
K. 30•46	ED	EB	MD	MC	SD	SC	GG	GF	OG	OF	BM	BL	GG	GF	OG	OF
K. 30•51	ED	EB	MD	MC	SD	SC	GG	GF	OG	OF	BM	BL	GG	GF	OG	OF
K. 30•56	ED	EB	ME	MD	SE	SD	GG	GF	OG	OF	BM	BL	GG	GF	OG	OF
K. 30•61	ED	EB	ME	MD	SE	SD	GG	GF	OG	OF	BM	BL	GG	GF	OG	OF
K. 30•73	EF	ED	ME	MD	SE	SD	GG	GF	OG	OF			GG	GF	OG	OF

Ports codes shown are not codified for all different body design (HSC - KSL - CSC - CSL - BSC - BSL).

Different ports are available on request. See page 49.

For more information please consult our pre-sales department.

EXTERNAL DRAIN PORTS

PORTS TYPE	GAS BSPP	SAE ODT
K. 30	GC	OA

01/10.2018

PORT SIZES

 Tightening torque for low pressure side port



 Tightening torque for high pressure side port

For reversible rotation, please consult only the tightening torque for high pressure side port

EUROPEAN FLANGED PORTS - 4 Bolts

EUROPEAN

Metric thread ISO 60° conforms to ISO/R 262

CODE	A	B	C		
	mm (inch)	mm (inch)	Thread Depth mm (inch)	Nm (lbf in)	Nm (lbf in)
EB	19 (0.75)	40 (1.57)	M 8 15 (0.59)	15 ⁺¹ (133 ÷ 142)	15 ⁺¹ (133 ÷ 142)
ED	27 (1.06)	51 (2.01)	M 10 15 (0.59)	20 ⁺¹ (177 ÷ 186)	30 ^{+2,5} (266 ÷ 288)
EF	33 (1.30)	62 (2.44)	M 12 17 (0.67)	25 ⁺¹ (221 ÷ 230)	50 ^{+2,5} (443 ÷ 465)

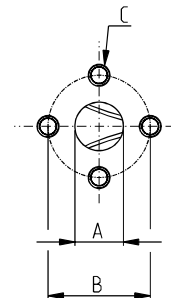

DCAT_006_024_21060533



SAE FLANGED PORTS J518 - Standard pressure series 3000 PSI

SSM

Metric thread ISO 60° conforms to ISO/R 262

CODE	A	B	C	D		
	mm (inch)	mm (inch)	mm (inch)	Thread Depth mm (inch)	Nm (lbf in)	Nm (lbf in)
MB	19 (0.75)	47,6 (1.87)	22,2 (0.87)	M 10 17 (0.67)	20 ⁺¹ (177 ÷ 186)	30 ^{+2,5} (266 ÷ 288)
MC	25,4 (1.00)	52,4 (2.06)	26,2 (1.03)	M 10 17 (0.67)	20 ⁺¹ (177 ÷ 186)	30 ^{+2,5} (266 ÷ 288)
MD	30,5 (1.20)	58,7 (2.31)	30,2 (1.19)	M 10 17 (0.67)	20 ⁺¹ (177 ÷ 186)	35 ^{+2,5} (310 ÷ 332)
ME	39,3 (1.55)	69,8 (2.75)	35,7 (1.41)	M 12 17 (0.67)	30 ^{+2,5} (266 ÷ 288)	60 ⁺⁵ (531 ÷ 575)

DCAT_006_025_21064252

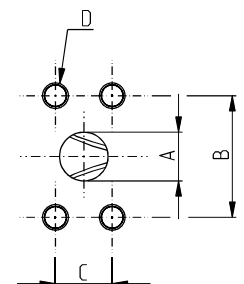

01/10.2018