

Ordering information

Example: **VP1 - 045 - L**

Frame size 045, 075, 095, 110 or 130

045, 075, 095, 110 or 130

Direction of rotation L Left hand
R Right hand

L Left hand
R Right hand

NOTE:

The VP1 is uni-directional.
 Consequently, the desired direction of rotation must be stated *when ordering*.

Standard model numbers

Designation	Ordering no. No Paint	Ordering no. Black Paint
VP1-045-R	378 0334	378 6169
VP1-045-L	378 0335	378 6170
VP1-075-R	378 0336	378 6171
VP1-075-L	378 0337	378 6172
VP1-095-R	378 6000	378 6003
VP1-095-L	378 6001	378 6002
VP1-110-R	378 4110	378 3814
VP1-110-L	378 4111	378 3815
VP1-130-R	378 4500	378 4507
VP1-130-L	378 4501	378 4508

VP1 in load sensing systems

When installed in a load sensing system, the VP1 supplies the correct amount of flow required by the various work functions currently engaged.

This means that energy consumption and heat generation are minimised and much reduced in comparison with a fixed displacement pump used in the same system.

Diagram 1 shows the required power (flow times pressure) in a constant flow system with a fixed displacement pump.

Diagram 2 shows the sharply reduced power requirement in a load sensing system with a variable displacement pump such as the VP1.

In both cases the pump pressure is slightly higher than what is required by the heaviest load ('Load 2') but the VP1, because of the much smaller flow being delivered, needs only the power indicated by the shaded area 'Load power'.

In a constant flow system, on the other hand, excess fluid is shunted to tank and the corresponding power, 'Wasted power' (shown in diagram 1), is a heat loss.

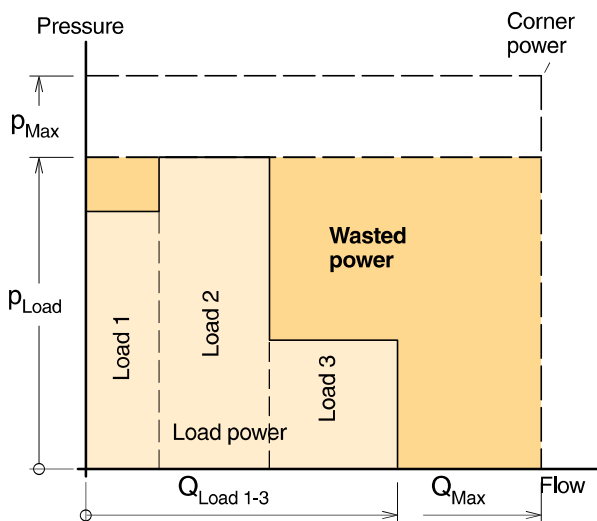

Diagram 1. Constant flow system with a fixed displacement pump.

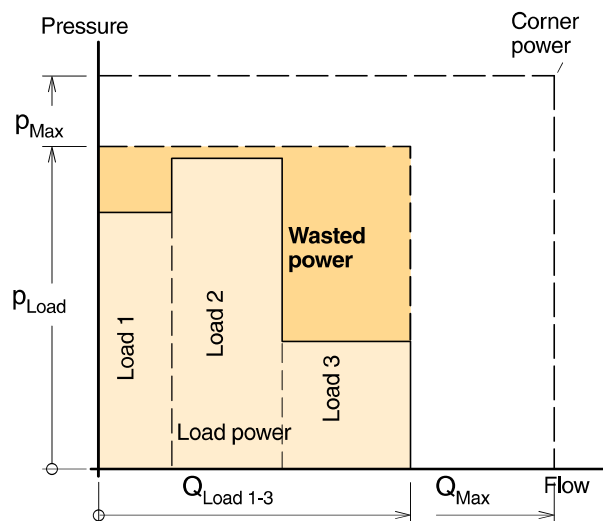

Diagram 2. Constant flow system with a variable displacement pump (e.g. VP1).

Systems comparison

System	Constant flow	Load-sensing
Pump	Fixed displ.	VP1 variable displ.
Pump adjustments	Pressure only	Pressure and flow
Load *	Some influence	Some influence
Energy consumption	High	Low
Heat generation	High	Low

* Simultaneous operation of loads with non-equal flows and pressures; refer to the above diagrams.

LS load sensing control function

Refer to corresponding hydraulic schematic below.

A selected 'opening' of the directional control valve spool corresponds to a certain flow to the work function. This flow, in turn, creates a pressure differential over the spool and, consequently, also a Δp between the pump outlet and the LS port.

When the differential pressure decreases (e.g. the directional valve is 'opened' further) the Δp also decreases and the LS valve spool moves to the left. The pressure to the setting pistons then decreases and the pump displacement increases.

The increase in pump displacement stops when the Δp finally reaches the setting (e.g. 25 bar) and the forces acting on the valve spool are equal.

If there is no LS signal pressure (e.g. when the directional valve is in the neutral, no-flow position) the pump only delivers sufficient flow to maintain the standby pressure as determined by the Δp setting.

LS control adjustments

Pressure limiter

Pump size	Factory setting [bar]	Max pressure intermittent [bar]
VP1-045/075	350	400
VP1-095/110/130	350	420

LS load sensing valve

Pump size	Factory setting [bar]	Min pressure [bar]	Max pressure [bar]
VP1-045/075	25	20	35
VP1-095/110/130	25	15	40

The factory setting, and the standard orifice sizes shown in the corresponding schematic below, will usually provide an acceptable directional valve characteristic as well as system stability.

For additional information, contact Parker Hannifin.

Hydraulic schematic for VP1-45/75

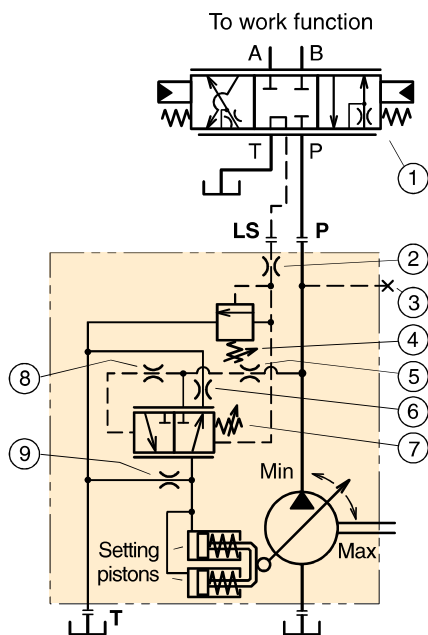

1. Directional, load sensing control valve
2. Load signal orifice (1.0 mm; fixed)
3. Gauge port
4. Signal pressure limiter adjustment
5. System pressure dampening nozzle (2.0 mm)
6. Return line nozzle (0.6 mm)
7. Standby (Δp) pressure adjustment
8. System pressure dampening orifice (fixed)
9. Bleed-off nozzle (0.6 mm).

Hydraulic schematic for VP1-095/-110/-130

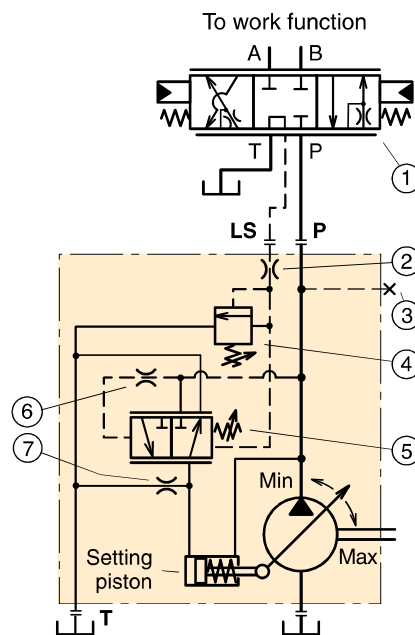

1. Directional, load sensing control valve
2. Load signal orifice (0.8 mm)
3. Gauge port
4. Signal pressure limiter adjustment
5. Standby (Δp) pressure adjustment
6. System pressure dampening orifice (fixed)
7. Bleed-off nozzle (1.2 mm)