

18/28/38P Series

High Pressure Filters

Max 520 l/min - 414 bar



Global Filtration Technology

High Pressure Filters

18/28/38P Series

TYPICAL APPLICATIONS

- Injection Moulding
- Machine Tools
- Die Casting
- Mobile Equipment
- Servo Controls

Parker Filtration engineered the 18/28/38P series of high pressure filters to satisfy demanding applications in the mobile and industrial markets throughout the world. With metric mounting and optional ISO 6149 ports, this new series is truly a global design.

Installed downstream of the pump, this new series with their wide range of high capacity Microglass III elements, offer excellent protection to system components.

Standard filters come complete with industry proven spool type bypass valve. For more critical applications such as servo or proportional controls, a no bypass high strength element combination ensures maximum protection.

The modular low hysteresis differential pressure indicator fitted to this series is unrivaled in its performance. Tests prove its accuracy and foolproof design to be a major advance in indicator technology.



TYPICAL APPLICATIONS



SPECIFICATION

Maximum Allowable Operating Pressure:

414 bar (6000 psi). Factor safety 3:1

Operating Temperature Range:

-40° to 120°C (-30°F to +250°F)

Materials of Construction:

SG iron head, steel bowl

Ports:

Inlet and outlet ports are threaded internally or flange faced

Port Style

Port Style	Model	18P	28P	38P
BSPF(G)	3/4"	1"	1 1/4", 1 1/2"	
SAE	12	16	20, 24	
ISO 6149	M27	M33	M42, M48	
SAE 6000-config	3/4"	1"	1 1/4"	
Metric 6000-M config*	3/4"	1"	1 1/4"	

*6000-M is SAE style with appropriate metric fixing threads

Bypass Valve & Indicator Settings:

Table below gives bypass valve and corresponding indicator setting

Bypass

3.5 bar

7.0 bar

Indicator

2.5 bar

5.0 bar

Weights (kg):

Model	Length 1	Length 2
18P	4.2	5.7
28P	6.7	9.2
38P	15.8	20.3

Fluid Compatibility:

Suitable for use with mineral oils, most water glycols and other water based fluids. For other fluids, please consult Filter Division Europe

Seals:

Head to bowl, diametral with anti-extrusion ring.

Materials - Nitrile or Fluoroelastomer*

Element Condition Indicators: (Differential Pressure Type)

Cartridge type visual, with auto reset. Cartridge type electrical, with auto reset and socket to DIN43650, protection class IP65

Electrical Ratings:

Power - 5 VA max, Current - 0.25 A max (resistive), Voltage - 28 VDC max, 28 VAC (50-60Hz) max, Contacts - normally open and normally closed, wired to DIN plug pin code

Filter Elements:

Microglass III supported with epoxy coated steel mesh. (See Table 4).

Element Collapse Rating:

Standard; 20 bar differential minimum. High collapse; 210 bar differential minimum

*Fluoroelastomers are available under various registered trademarks, including Viton (a registered trademark of DuPont) and Fluorel (a registered trademark of 3M)

Model	A	B	C	D	E (A/F)	F	G	H	J	K	L	M	N	P
18P-1	198 (7.79)	32 (1.26)	26 (1.02)	75 (2.95)	24 (0.94)	100 (3.94)	98 (3.86)	40 (1.57)	20 (0.79)	80 (3.15)	40 (1.57)	55 (2.16)	110 (4.33)	M8 x 1.25 x12 (0.47) deep
18P-2	293 (11.53)													M10 x 1.5 x11 (0.43) deep
28P-1	228 (8.97)	40 (1.57)	29 (1.14)	93 (3.66)	40 (1.14)		120 (4.72)	55 (2.16)	27.5 (1.07)	90 (3.54)	45 (1.77)	62 (2.44)	124 (4.88)	M10 x 1.5 x11 (0.43) deep
28P-2	337 (13.26)													M10 x 1.5 x12 (0.47) deep
38P-1	329 (12.95)	44 (1.73)	35 (1.38)	128 (5.04)	36 (1.42)		160 (6.30)	50 (1.97)	25 (0.98)	120 (4.72)	60 (2.36)	81 (3.19)	162 (6.38)	M10 x 1.5 x12 (0.47) deep
38P-2	448 (17.64)													M10 x 1.5 x12 (0.47) deep

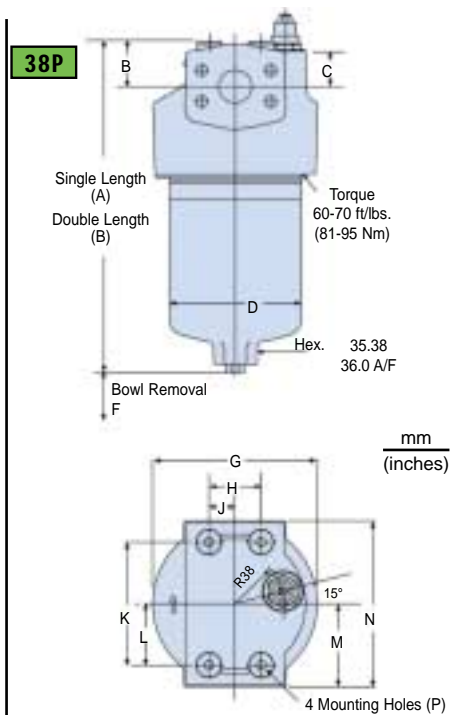
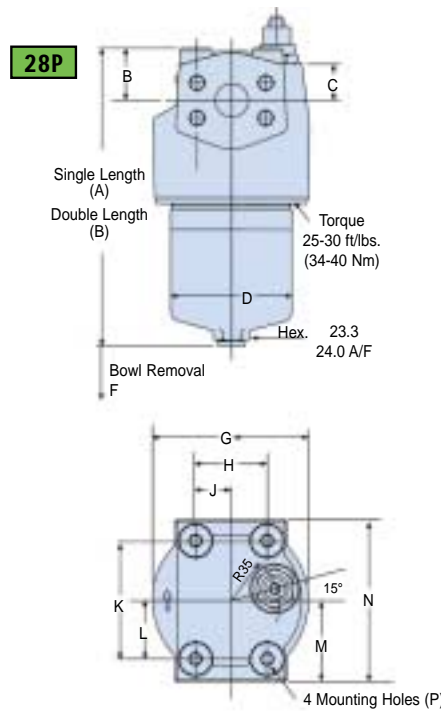
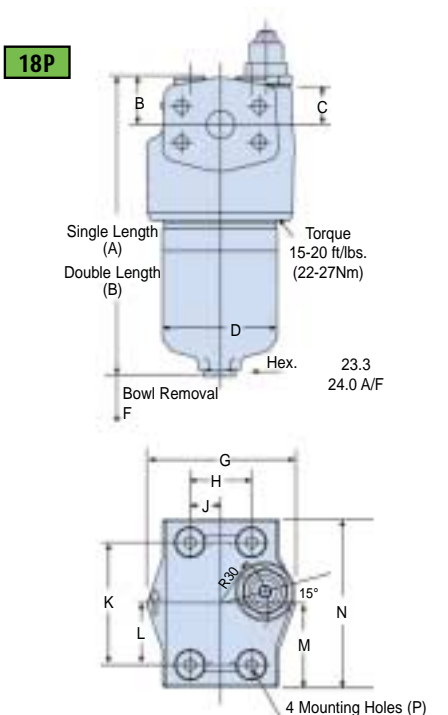

High Pressure Filters

18/28/38P Series

FLANGE FACE DETAILS

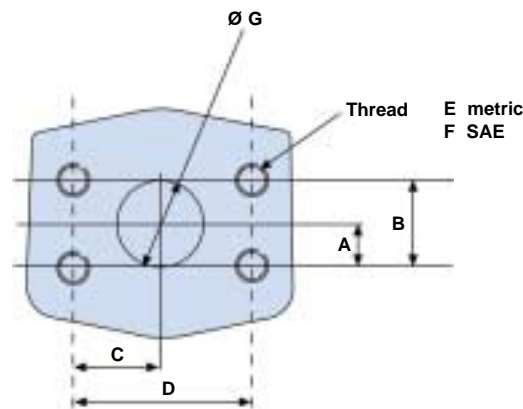

Model mm (inches)	A	B	C	D	E	F	G
18P	11.9 (0.47)	23.8 (0.94)	25.4 (1.00)	50.8 (2.0)	M10 x 1.5-6H x 18 Deep	³ / ₈ -16 UNC-2B x 18 Deep	19.0 (0.75)
28P	14 (0.55)	27.8 (1.09)	28.0 (1.10)	57.1 (2.25)	M12 x 1.75-6H x 20 Deep	⁷ / ₁₆ -14 UNC-2B x 20 Deep	25.4 (1.0)
38P	15.7 (0.62)	31.7 (1.25)	33.0 (1.30)	66.7 (2.62)	M14 x 2-6H x 20 Deep	¹ / ₂ -13 UNC-2B x 20 Deep	31.8 (1.25)

INDICATOR DETAILS

Element Condition Indicators:

**VISUAL AUTO RESET
CODE M2**

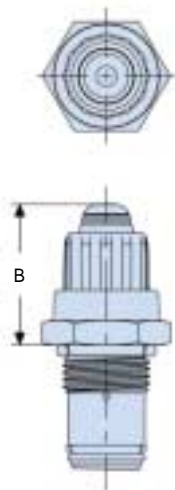

**48 VAC ELECTRICAL VISUAL INDICATOR
CODE E2**

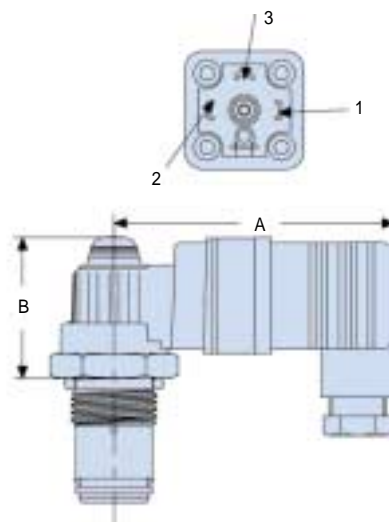

Option	Description	Connection/Voltage	Wiring	"A"	"B"
M2	Visual Auto Reset	N/A	N/A	N/A	1.44 (36.6)
E2	Electrical – Visual	Din 43650 3 Pole + Earth 5A@48 VAC, 3A@28VDC	Pin 1 – Common Pin 2 – Normally Closed Pin 3 – Normally Open	2.90 (73.7)	1.44 (36.6)

Note: For full indicator specifications see Section 6.

PRESSURE DROP CURVES

If the medium used has a viscosity different from 30 cSt, pressure drop over the filter can be estimated as follows :-

$$\Delta p = (\Delta p_{30} \times \text{viscosity of medium used}) / 30 \text{ cSt}$$

18P-1 Element Only

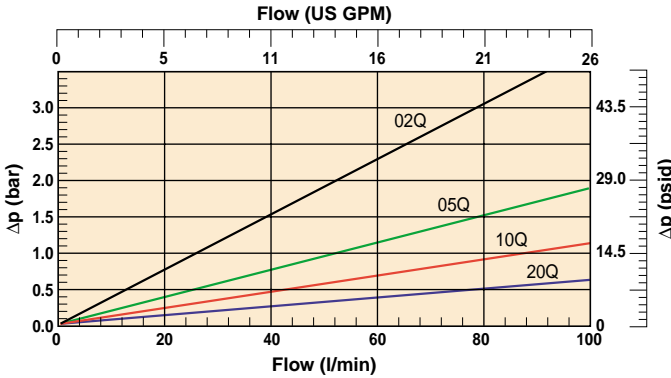

18P-2 Element Only

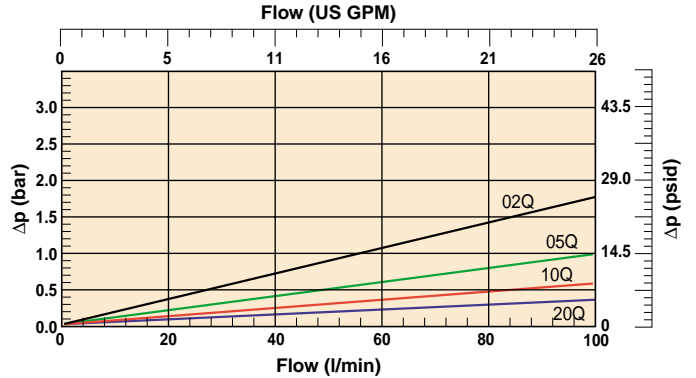

18P-1 Empty Housing and High Collapse

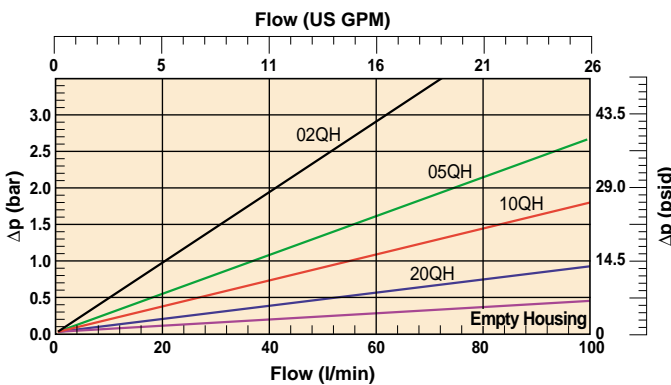

18P-2 High Collapse Elements Only

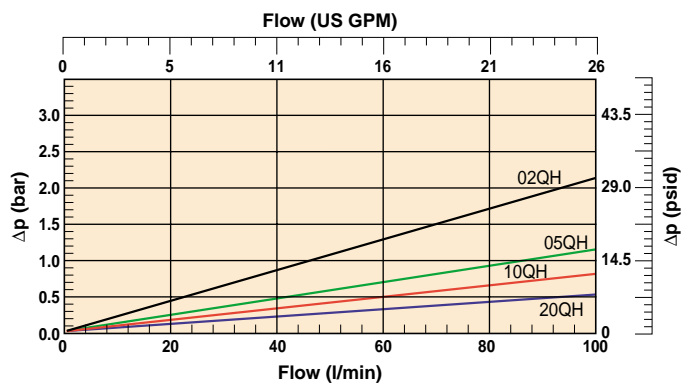

28P-1 Element Only

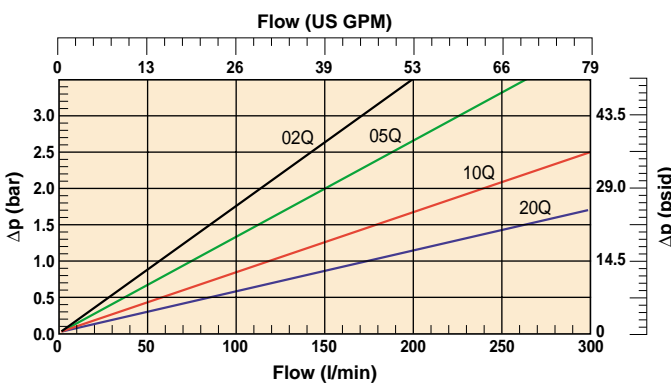

28P-2 Element Only

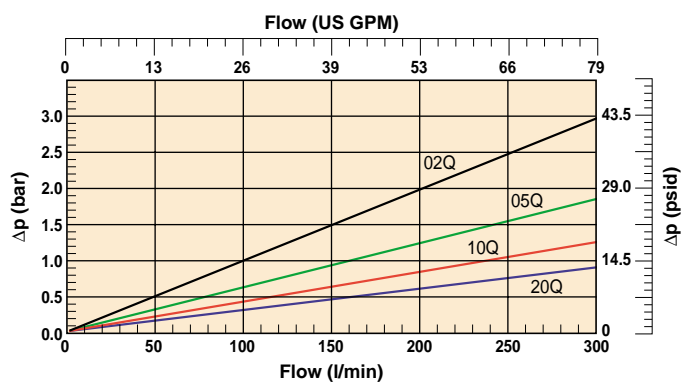

28P-1 Empty Housing and High Collapse

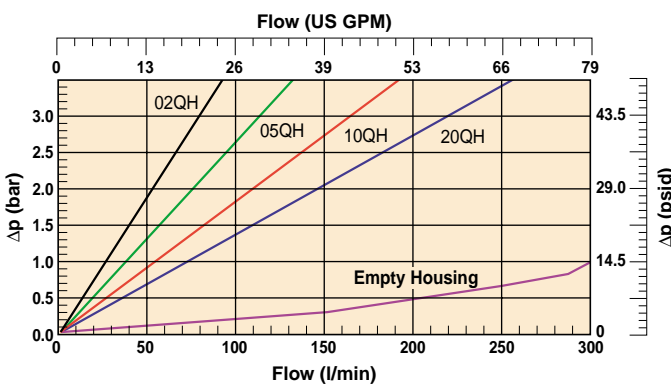

28P-2 High Collapse Elements Only

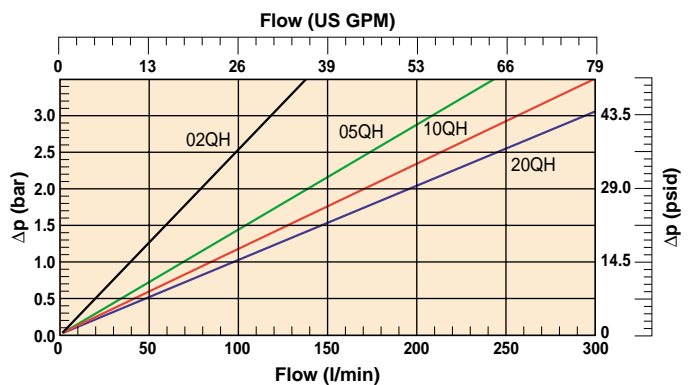

High Pressure Filters

18/28/38P Series

38P-1 Element Only

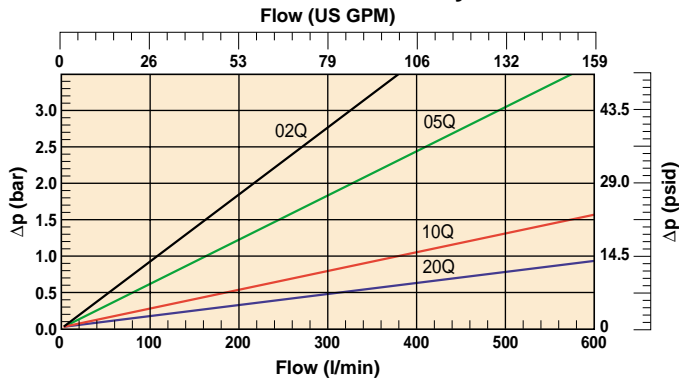

38P-2 Element Only

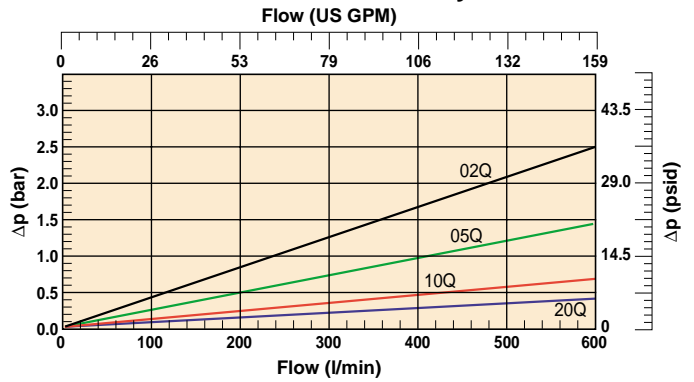

38P-1 Empty Housing and High Collapse

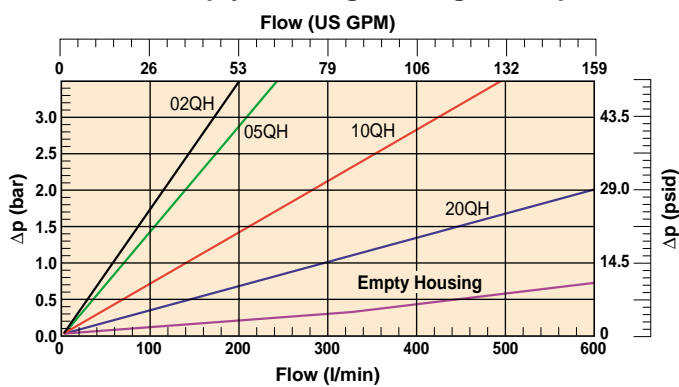

38P-2 High Collapse Elements Only

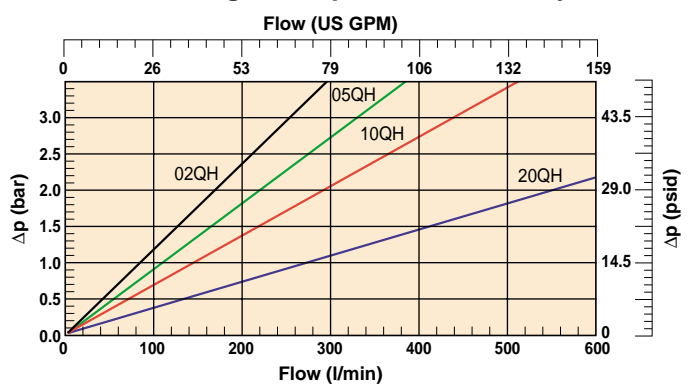

CAPACITY IN GRAMS

Media Code	38P-1 (98 psid)	38P-2 (98 psid)	28P-1 (98 psid)	28P-2 (98 psid)	18P-1 (98 psid)	18P-2 (98 psid)
02Q	74	111	28	48	7.4	22.7
05Q	78	105	28	50	9.4	23.5
10Q	67	101	24	48	8.0	17.2
20Q	60	100	24	48	8.6	17.7
02QH	57	87	24	38	6.3	17.8
05QH	61	88	27	38	8.8	19.6
10QH	56	80	23	38	7.2	16.1
20QH	54	78	22	37	7.2	12.6

Element Service

- A. Stop the system's power unit.
- B. Relieve any system pressure in the filter line.
- C. Drain the filter bowl if drain port option is provided.
- D. Rotate the bowl clockwise (left) and remove.
- E. Remove element by pulling downward with a slight twisting motion and discard.
- F. Check bowl o-ring and anti-extrusion ring for damage and replace if necessary.
- G. Lubricate element o-ring with system fluid and locate element in filter head.
- H. Install bowl by rotating counter-clockwise (right) and tighten to specified torque.
 - 18P — 15-20ft. lbs (22-27 Nm)
 - 28P — 25-30ft. lbs (34-40 Nm)
 - 38P — 60-70ft. lbs (81-95 Nm)
- I. Confirm there are no leaks after powering the system.

Parts List

Index	Description
1	Head Assembly
2	Element
3	Bowl
	Single length
	Double length
	Indicators
4	M2 – Visual autoreset
5	E2 – Electrical/Visual w/DIN connection
6	Bowl Seal
7	Bowl Anti-extrusion Ring
	*Seal Kit – (Nitrile)
	*Seal Kit – (Fluoroelastomer)

*Includes bowl o-ring, bowl anti-extrusion washer and indicator o-rings

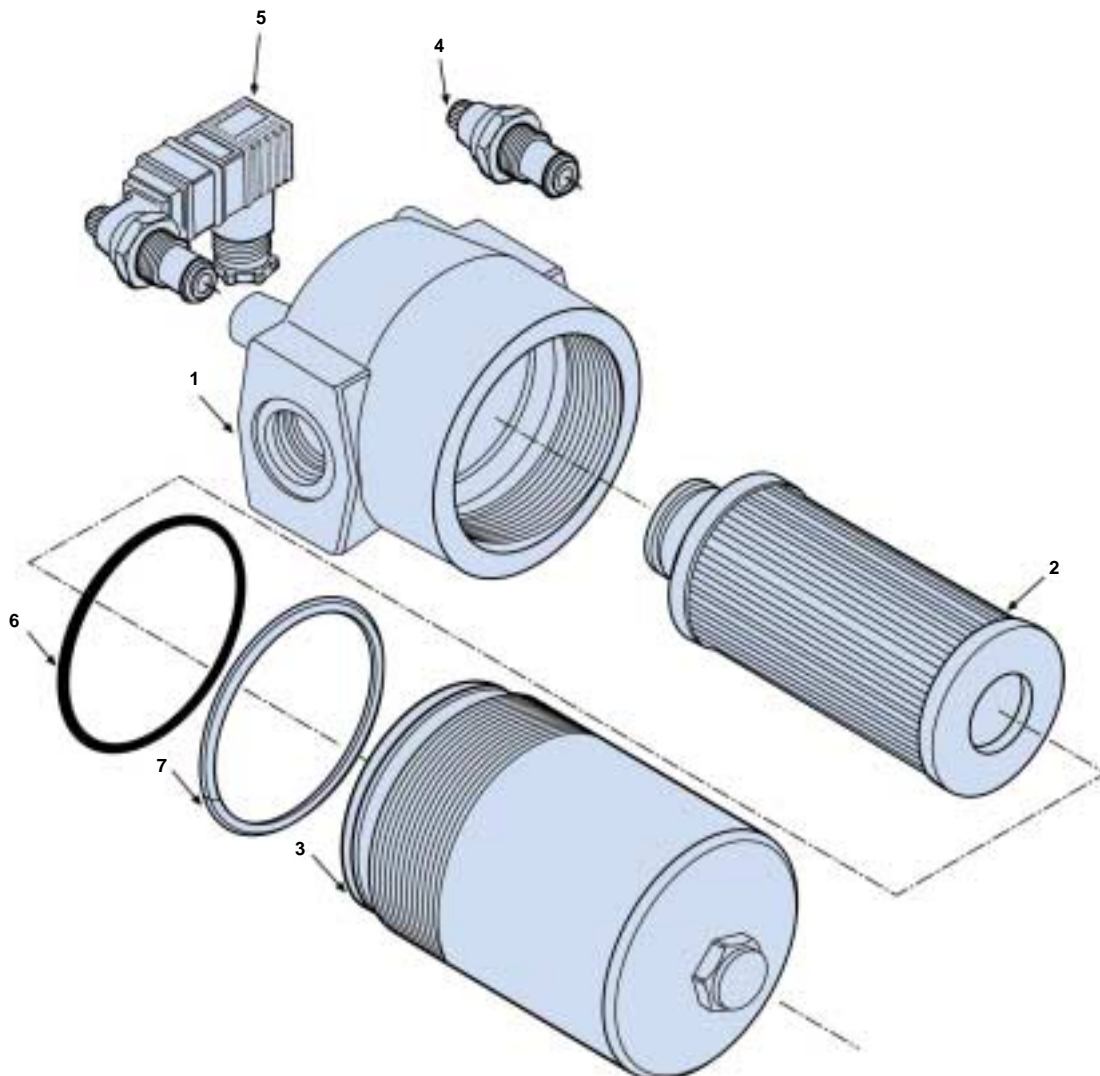

High Pressure Filters

18/28/38P Series

PREFERRED PRODUCTS TABLE

The following filters are supplied with 7.0 bar bypass and Nitrile seals.					
Part Number	Part Number	Flow (l/min)	Media Rating	Ports	Replacement Elements
18P-1-02Q-M2-98-B2B2-1	18P-1-02Q-E2-98-B2B2-1	35	02Q	G ^{3/4}	G04242
18P-1-05Q-M2-98-B2B2-1	18P-1-05Q-E2-98-B2B2-1	60	05Q	G ^{3/4}	G04243
18P-1-10Q-M2-98-B2B2-1	18P-1-10Q-E2-98-B2B2-1	90	10Q	G ^{3/4}	G04244
18P-1-20Q-M2-98-B2B2-1	18P-1-20Q-E2-98-B2B2-1	100	20Q	G ^{3/4}	G04245
18P-2-02Q-M2-98-B2B2-1	18P-2-02Q-E2-98-B2B2-1	60	02Q	G ^{3/4}	G04250
18P-2-05Q-M2-98-B2B2-1	18P-2-05Q-E2-98-B2B2-1	90	05Q	G ^{3/4}	G04251
18P-2-10Q-M2-98-B2B2-1	18P-2-10Q-E2-98-B2B2-1	110	10Q	G ^{3/4}	G04252
18P-2-20Q-M2-98-B2B2-1	18P-2-20Q-E2-98-B2B2-1	130	20Q	G ^{3/4}	G04253
28P-1-02Q-M2-98-C2C2-1	28P-1-02Q-E2-98-C2C2-1	80	02Q	G1	G04258
28P-1-05Q-M2-98-C2C2-1	28P-1-05Q-E2-98-C2C2-1	100	05Q	G1	G04259
28P-1-10Q-M2-98-C2C2-1	28P-1-10Q-E2-98-C2C2-1	150	10Q	G1	G04260
28P-1-20Q-M2-98-C2C2-1	28P-1-20Q-E2-98-C2C2-1	200	20Q	G1	G04261
28P-2-02Q-M2-98-C2C2-1	28P-2-02Q-E2-98-C2C2-1	120	02Q	G1	G04266
28P-2-05Q-M2-98-C2C2-1	28P-2-05Q-E2-98-C2C2-1	160	05Q	G1	G04267
28P-2-10Q-M2-98-C2C2-1	28P-2-10Q-E2-98-C2C2-1	200	10Q	G1	G04268
28P-2-20Q-M2-98-C2C2-1	28P-2-20Q-E2-98-C2C2-1	240	20Q	G1	G04269
38P-1-02Q-M2-98-D2D2-1	38P-1-02Q-E2-98-D2D2-1	130	02Q	G1 ^{1/4}	G04274
38P-1-05Q-M2-98-D2D2-1	38P-1-05Q-E2-98-D2D2-1	250	05Q	G1 ^{1/4}	G04275
38P-1-10Q-M2-98-D2D2-1	38P-1-10Q-E2-98-D2D2-1	360	10Q	G1 ^{1/4}	G04276
38P-1-20Q-M2-98-D2D2-1	38P-1-20Q-E2-98-D2D2-1	450	20Q	G1 ^{1/4}	G04277
38P-2-10Q-M2-98-D2D2-1	38P-2-10Q-E2-98-D2D2-1	500	10Q	G1 ^{1/4}	G04284

Note: Filter assemblies ordered from the Part Number Matrix below are on extended lead times. Where possible, please make your selection from the table above.

PART NUMBER MATRIX

Table 1 F3	Table 2 28P	Table 3 1	Table 4 10Q	Table 5 M2	Table 6 98	Table 7 C2C2	Table 8 1	Table 9 -
----------------------	-----------------------	---------------------	-----------------------	----------------------	----------------------	------------------------	---------------------	---------------------

Table 1

Seals	
Description	SYMBOL
Nitrile	O
Fluoroelastomer*	F3

Table 2

Model Number	
Symbol	
18P	
28P	
38P	

Table 5

Indicator Options	
Description	SYMBOL
None	N
Visual (Auto reset)	M2
FPC Visual (Auto reset)	V6
Visual Electrical Din Plug	E2
FPC Electrical Din Plug	TW6
FPC Electronic L.E.D.	FW6

Note: Indicator Differential Pressure Settings
2.5 bar with 3.5 bar bypass
5.0 bar with 7.0 bar bypass
5.0 bar with no bypass

Table 7

Ports		
Description	MODEL	SYMBOL
G ^{3/4} " Thread	18P	B2B2
1/2, SAE Thread		M4M4
M27, ISO 6149		B3B3
3/4" 6000-M Flange Face		Y3Y3
3/4" 6000-M Config. Flange Face		Y9Y9
G1	28P	C2C2
1/2 SAE Thread		N4N4
M33, ISO 6149		C3C3
1" 6000-M Flange Face		Y3Y3
1" 6000-M Config. Flange Face		Y9Y9
G1 ^{1/2} " Thread	38P	D2D2
G1 ^{1/2} " Thread		E2E2
20 SAE Thread		O4O4
24 SAE Thread		P4P4
M42, ISO 6149		D3D3
M48, ISO 6149		E3E3
1 ^{1/4} " 6000-M Flange Face		Y3Y3
1 ^{1/4} " 6000-M Config. Flange Face		Y9Y9

Table 3

Housing Length	
Description	SYMBOL
Single Length	1
Double Length	2

Table 6

Bypass Indicator Setting	
Description	SYMBOL
3.5 bar	50
7.0 bar	98
No bypass	X

Table 4

Degree of Filtration						
Average filtration ratio β (ISO 16889) / particle size μm(c)						CODE
2	10	75	100	200	1000	
N/A	N/A	N/A	N/A	N/A	4.5	02Q
						02QH
N/A	N/A	4.5	5	6	7	05Q
						05QH
N/A	6	8.5	9	10	12	10Q
						10QH
6	11	17	18	20	22	20Q
						20QH

Table 8

Options	
Description	SYMBOL
None	I
No Bypass	II

Table 9

Design Number
Applied to the filter assembly by Parker Filtration.