

# Vane Pumps

Series PVS  
Variable Displacement

aerospace  
climate control  
electromechanical  
filtration  
fluid & gas handling  
**hydraulics**  
pneumatics  
process control  
sealing & shielding



ENGINEERING YOUR SUCCESS.



## **WARNING – USER RESPONSIBILITY**

**FAILURE OR IMPROPER SELECTION OR IMPROPER USE OF THE PRODUCTS DESCRIBED HEREIN OR RELATED ITEMS CAN CAUSE DEATH, PERSONAL INJURY AND PROPERTY DAMAGE.**

This document and other information from Parker-Hannifin Corporation, its subsidiaries and authorized distributors provide product or system options for further investigation by users having technical expertise.

The user, through its own analysis and testing, is solely responsible for making the final selection of the system and components and assuring that all performance, endurance, maintenance, safety and warning requirements of the application are met. The user must analyze all aspects of the application, follow applicable industry standards, and follow the information concerning the product in the current product catalog and in any other materials provided from Parker or its subsidiaries or authorized distributors.

To the extent that Parker or its subsidiaries or authorized distributors provide component or system options based upon data or specifications provided by the user, the user is responsible for determining that such data and specifications are suitable and sufficient for all applications and reasonably foreseeable uses of the components or systems.

## **Offer of Sale**

Please contact your Parker representation for a detailed "Offer of Sale".

<b>Contents</b>	<b>Page</b>
Characteristics.....	4
Technical data .....	4
Selection table.....	4
Ordering code .....	4
Standard Pressure Compensator .....	5
Compensator type S (PVS: Standard pressure compensator).....	5
Schematic diagram and performance curves.....	5
Task and function .....	5
Dimensions .....	5
Double Pressure Compensator .....	6
Compensator type D, low pressure – high pressure (PVD: Two-stage pressure compensator).....	6
Schematic diagram and performance curves.....	6
Task and function .....	6
Dimensions .....	6
Pump Combinations .....	7
PVS pumps with thru drive.....	7
Mounting kits for pump combinations.....	7

**Technical data**

Displacement	[cm <sup>3</sup> /rev]	from 8 to 50
Operating pressures		
Outlet	[bar]	140
Inlet min.	[bar]	1.0 0.8 absolute
Drain port	[bar]	max. 0.5
Speed ranges	[min <sup>-1</sup> ]	1000...1800
Press. fluid temperature	[°C]	-10...+70
Viscosity range	[mm <sup>2</sup> /s]	22 - 100 800 (short-term at start up)
Rotation		clockwise

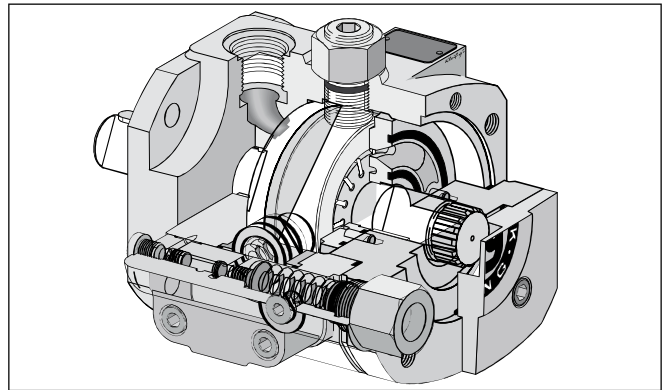

**Selection table**

Model	Displacement in cm <sup>3</sup> /rev	Output flow at 1500 rpm in l/min	Input power at nominal pressure in kW	Weight in kg single pump	Weight in kg main pump	Weight in kg intermediate pump	Weight in kg second pump
PVS08	8.3	12	3.65	8.9	8.9	8.8	8.8
PVS12	12.8	19	5.0	8.9	8.9	8.8	8.8
PVS16	16	23	8.7	18.1	16.9	18.0	16.8
PVS25	24	35	9.9	18.1	16.9	18.0	16.8
PVS32	31	45	12.7	33.2	30.8	33.0	30.6
PVS40	40	60	15.9	33.2	30.8	33.0	30.6
PVS50	51.5	75	19.7	33.2	30.8	33.0	30.6

**Ordering code**

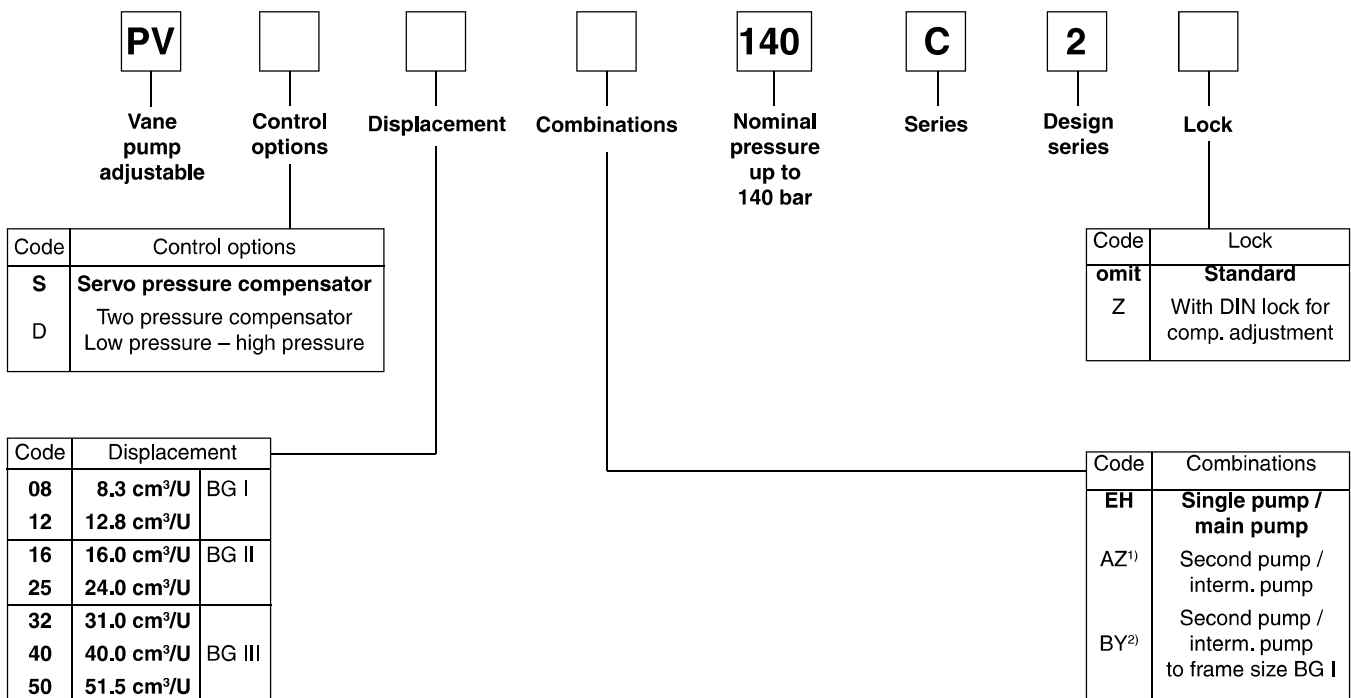

<sup>1)</sup> only for BG II and BG III

<sup>2)</sup> only for BG I

**Compensator type S (PVS: Standard pressure compensator)**

The pressure is mechanically adjustable via the preload of the pilot control cartridge spring.

**Schematic diagram and performance curves**

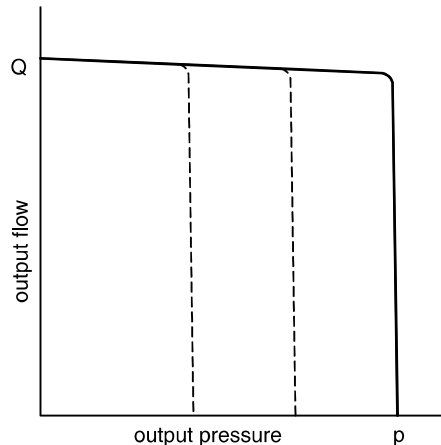
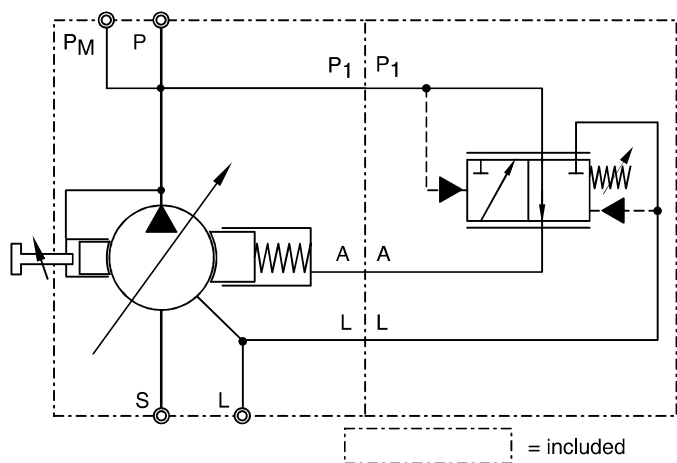

**Task and function**

When reaching the set pressure on the compensator, the pressure flow of the servo-controlled pump is automatically adjusted to the actual pressure flow requirement of the consumer.

Thus an undesired flow is avoided and only the required medium amount is delivered. As long as the system pressure is lower than the set pressure on the compensator, the stroke ring is kept in the position of

maximum eccentricity, so that the pump continues its full delivery. If the system pressure exceeds the set compensator pressure, the control valve opens, and the pressure on the control piston is relieved. The stroke ring is moved by the auxiliary piston up to the central position to the point where the pressure flow corresponds to the system requirements at the set pressure. The pump is regulated.

**Dimensions**

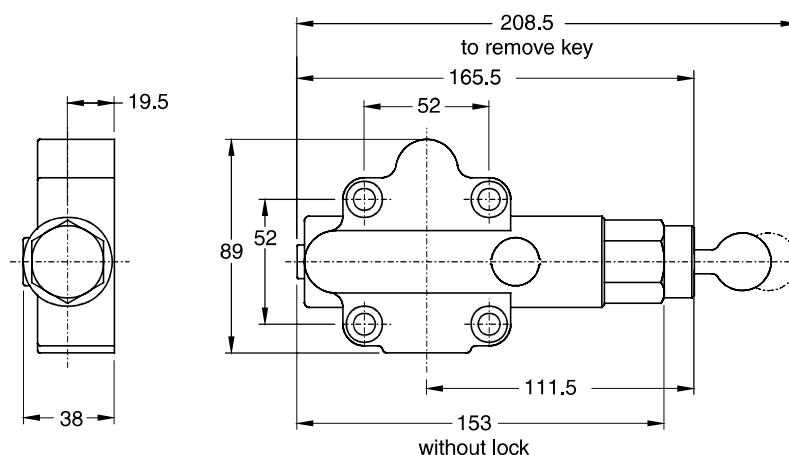

**Compensator type D, low pressure – high pressure (PVD: Two-stage pressure compensator)**

High pressure and low pressure mechanically adjustable via spring pre-loading, electric switching.

**Schematic diagram and performance curves**

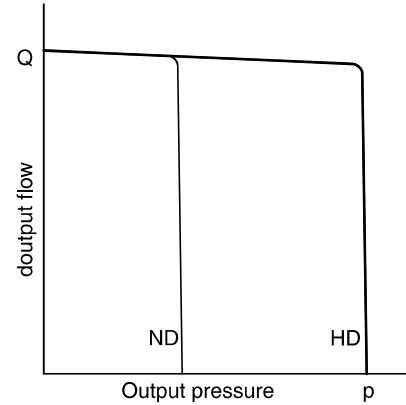
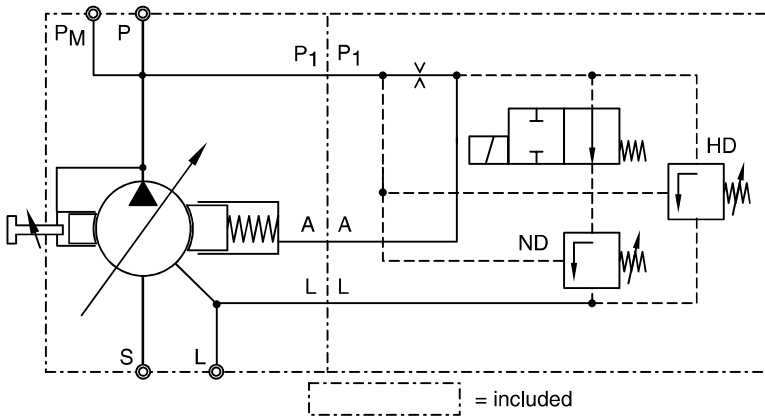

**Task and function**

The double pressure compensator offers the user the possibility to electrically select between two different pressures. Hydraulic systems, where a higher pressure is only needed in peaks, can be created to be very energy-saving, based on such a design. The double pressure compensator can also be labelled as a double servo pressure compensator, divided into low and high pressure stages. Both compensator pistons are connected together via an integrated directional valve.

Initially both compensator pistons are pressurised with system pressure at the unloaded directional valve. The compensator piston with the lower spring pre-loading is responsible for the system pressure. If the directional valve piston is changed over from LP to HP via electrical signal, the connection to the low pressure compensator piston is interrupted. Then, only the high pressure compensator piston is connected to the pilot oil space. The actual control process for the pump corresponds to one from a servo pressure compensator.

**Dimensions**

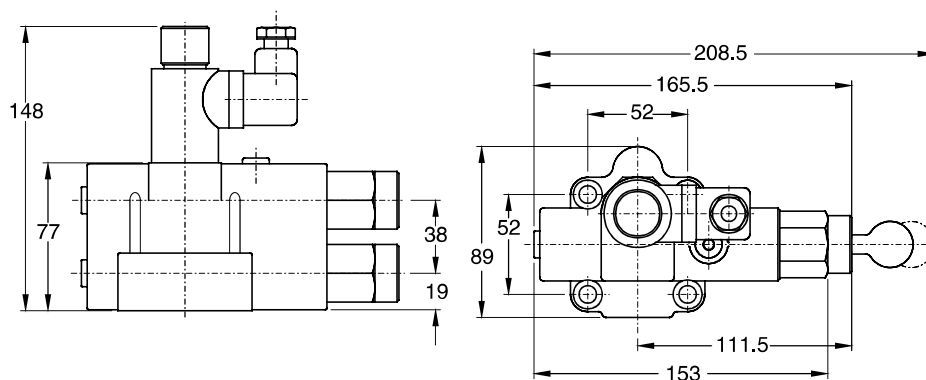

**PVS pumps with thru drive**

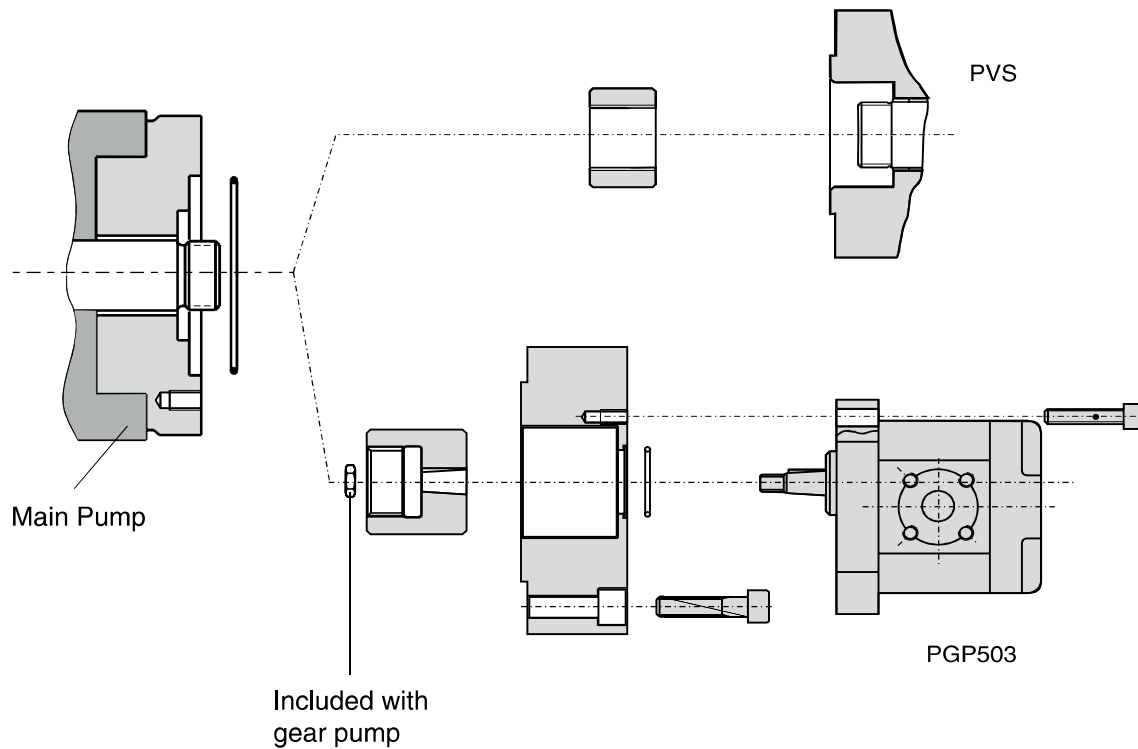

**Mounting kits for pump combinations**

MK-PVSBG1-PGP503  
MK-PVSBG1-PVSBG1

MK-PVSBG2-PGP503  
MK-PVSBG2/3-PVSBG1  
MK-PVSBG2/3-PVSBG2/3

MK-PVSBG3-PGP503

# Parker Worldwide

**AE – UAE, Dubai**  
Tel: +971 4 8127100  
parker.me@parker.com

**AR – Argentina, Buenos Aires**  
Tel: +54 3327 44 4129

**AT – Austria, Wiener Neustadt**  
Tel: +43 (0)2622 23501-0  
parker.austria@parker.com

**AT – Eastern Europe, Wiener Neustadt**  
Tel: +43 (0)2622 23501 900  
parker.easteurope@parker.com

**AU – Australia, Castle Hill**  
Tel: +61 (0)2-9634 7777

**AZ – Azerbaijan, Baku**  
Tel: +994 50 2233 458  
parker.azerbaijan@parker.com

**BE/LU – Belgium, Nivelles**  
Tel: +32 (0)67 280 900  
parker.belgium@parker.com

**BR – Brazil, Cachoeirinha RS**  
Tel: +55 51 3470 9144

**BY – Belarus, Minsk**  
Tel: +375 17 209 9399  
parker.belarus@parker.com

**CA – Canada, Milton, Ontario**  
Tel: +1 905 693 3000

**CH – Switzerland, Etoy**  
Tel: +41 (0) 21 821 02 30  
parker.switzerland@parker.com

**CL – Chile, Santiago**  
Tel: +56 2 623 1216

**CN – China, Shanghai**  
Tel: +86 21 2899 5000

**CZ – Czech Republic, Klecany**  
Tel: +420 284 083 111  
parker.czechrepublic@parker.com

**DE – Germany, Kaarst**  
Tel: +49 (0)2131 4016 0  
parker.germany@parker.com

**DK – Denmark, Ballerup**  
Tel: +45 43 56 04 00  
parker.denmark@parker.com

**ES – Spain, Madrid**  
Tel: +34 902 330 001  
parker.spain@parker.com

**FI – Finland, Vantaa**  
Tel: +358 (0)20 753 2500  
parker.finland@parker.com

**FR – France, Contamine s/Arve**  
Tel: +33 (0)4 50 25 80 25  
parker.france@parker.com

**GR – Greece, Athens**  
Tel: +30 210 933 6450  
parker.greece@parker.com

**HK – Hong Kong**  
Tel: +852 2428 8008

**HU – Hungary, Budapest**  
Tel: +36 1 220 4155  
parker.hungary@parker.com

**IE – Ireland, Dublin**  
Tel: +353 (0)1 466 6370  
parker.ireland@parker.com

**IN – India, Mumbai**  
Tel: +91 22 6513 7081-85

**IT – Italy, Corsico (MI)**  
Tel: +39 02 45 19 21  
parker.italy@parker.com

**JP – Japan, Fujisawa**  
Tel: +81 (0)4 6635 3050

**KR – South Korea, Seoul**  
Tel: +82 2 559 0400

**KZ – Kazakhstan, Almaty**  
Tel: +7 7272 505 800  
parker.easteurope@parker.com

**LV – Latvia, Riga**  
Tel: +371 6 745 2601  
parker.latvia@parker.com

**MX – Mexico, Apodaca**  
Tel: +52 81 8156 6000

**MY – Malaysia, Shah Alam**  
Tel: +60 3 7849 0800

**NL – The Netherlands, Oldenzaal**  
Tel: +31 (0)541 585 000  
parker.nl@parker.com

**NO – Norway, Ski**  
Tel: +47 64 91 10 00  
parker.norway@parker.com

**NZ – New Zealand, Mt Wellington**  
Tel: +64 9 574 1744

**PL – Poland, Warsaw**  
Tel: +48 (0)22 573 24 00  
parker.poland@parker.com

**PT – Portugal, Leca da Palmeira**  
Tel: +351 22 999 7360  
parker.portugal@parker.com

**RO – Romania, Bucharest**  
Tel: +40 21 252 1382  
parker.romania@parker.com

**RU – Russia, Moscow**  
Tel: +7 495 645-2156  
parker.russia@parker.com

**SE – Sweden, Spånga**  
Tel: +46 (0)8 59 79 50 00  
parker.sweden@parker.com

**SG – Singapore**  
Tel: +65 6887 6300

**SK – Slovakia, Banská Bystrica**  
Tel: +421 484 162 252  
parker.slovakia@parker.com

**SL – Slovenia, Novo Mesto**  
Tel: +386 7 337 6650  
parker.slovenia@parker.com

**TH – Thailand, Bangkok**  
Tel: +662 717 8140

**TR – Turkey, Istanbul**  
Tel: +90 216 4997081  
parker.turkey@parker.com

**TW – Taiwan, Taipei**  
Tel: +886 2 2298 8987

**UA – Ukraine, Kiev**  
Tel: +380 44 494 2731  
parker.ukraine@parker.com

**UK – United Kingdom, Warwick**  
Tel: +44 (0)1926 317 878  
parker.uk@parker.com

**US – USA, Cleveland (industrial)**  
Tel: +1 216 896 3000

**US – USA, Lincolnshire (mobile)**  
Tel: +1 847 821 1500

**VE – Venezuela, Caracas**  
Tel: +58 212 238 5422

**ZA – South Africa, Kempton Park**  
Tel: +27 (0)11 961 0700  
parker.southafrica@parker.com



## European Product Information Centre

Free phone: 00 800 27 27 5374  
(from AT, BE, CH, CZ, DE, EE, ES, FI, FR, IE,  
IL, IS, IT, LU, MT, NL, NO, PT, SE, SK, UK)

## US Product Information Centre

Free phone: 1-800-27 27 537  
www.parker.com



**Introduction**

**Pump with Standard Pressure Compensator, code PVS**

**Pump with Pressure Flow Compensator, code PVM**

**1**

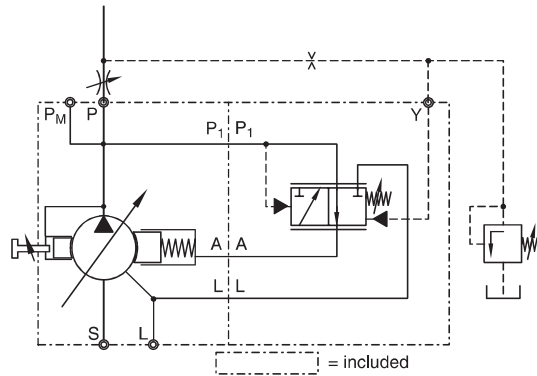
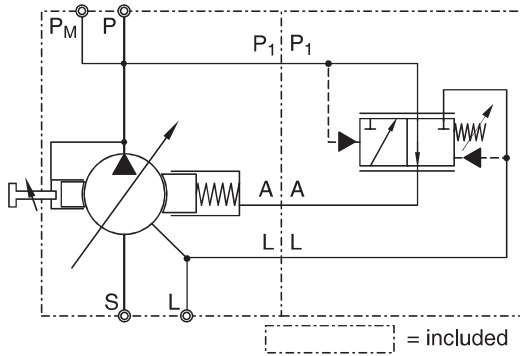

**With thru shaft option for multiple pump options**  
for open circuit

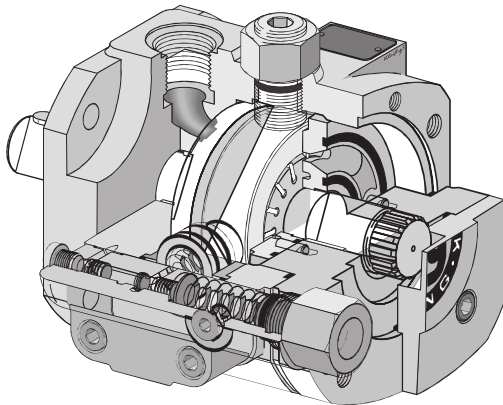

- Mounting pattern according to VDMA 24560/1 specification
- 4 bolt flange ISO 3019/2 (metric)
- Fast response
- Wide range of controls for diverse tasks
- Low noise level
- Good efficiency

**Pump with Two-Stage Compensator, code PVH**

**Pump with Proportional Pressure Compensator, code PVL**

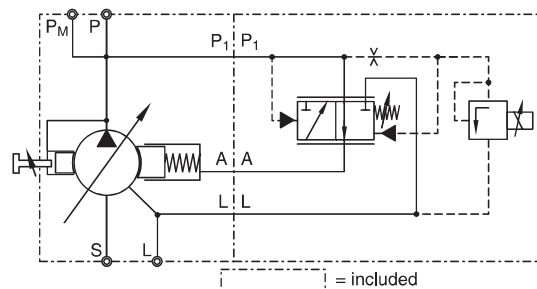
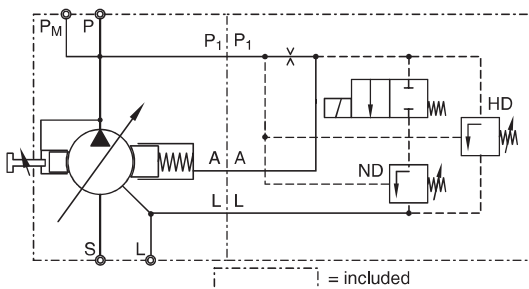

PVS.PMD RH



**Characteristics**

**Technical data**

Displacement [cm <sup>3</sup> /rev]	from 8 to 50
Operating pressures	
Outlet [bar]	140
Inlet min. [bar]	1.0
	0.8 absolute
Drain port [bar]	max. 0.5
Speed ranges [min <sup>-1</sup> ]	1000...1800
Press. fluid temperature [°C]	-10...+70
Viscosity range [mm <sup>2</sup> /s]	22 - 100
	800 (short-term at start up)
Rotation	clockwise

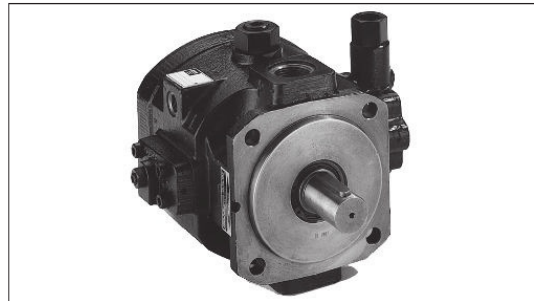

1

**Selection table**

Model	Displacement in cm <sup>3</sup> /rev	Output flow at 1500 rpm in l/min	Input power at nominal pressure in kW	Weight in kg single pump	Weight in kg main pump	Weight in kg intermediate pump	Weight in kg second pump
PVS08	8.3	12	3.65	8.9	8.9	8.8	8.8
PVS12	12.8	19	5.0	8.9	8.9	8.8	8.8
PVS16	16	23	8.7	18.1	16.9	18.0	16.8
PVS25	24	35	9.9	18.1	16.9	18.0	16.8
PVS32	31	45	12.7	33.2	30.8	33.0	30.6
PVS40	40	60	15.9	33.2	30.8	33.0	30.6
PVS50	51.5	75	19.7	33.2	30.8	33.0	30.6

**Ordering code**

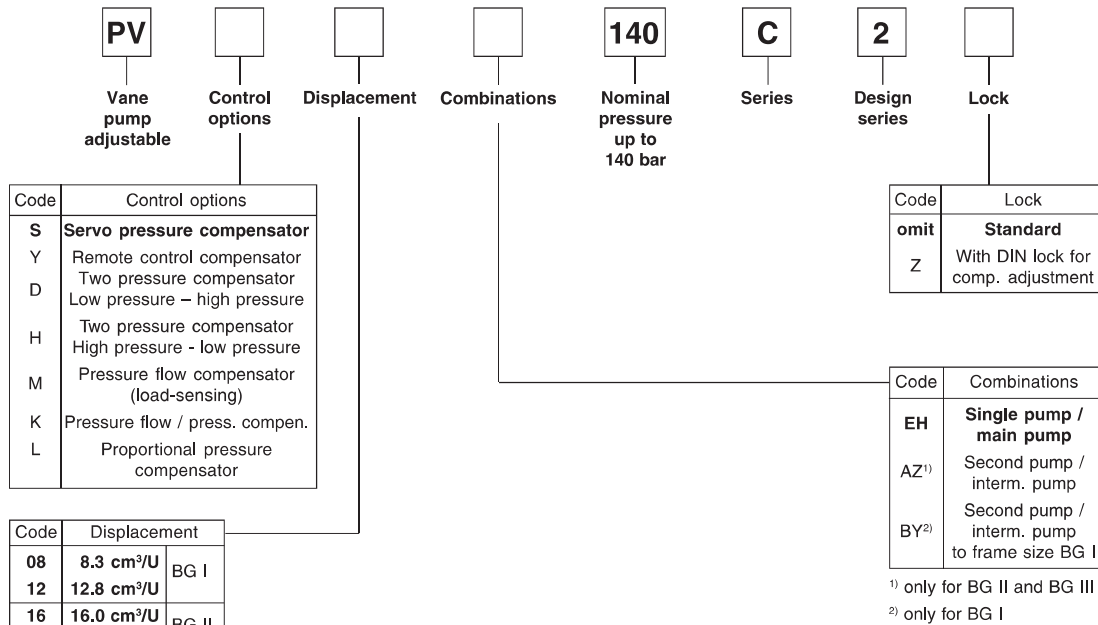

**Bold letters = Short-term availability**

PVS,PMD RH



**1**

**PVS 08 / 12**

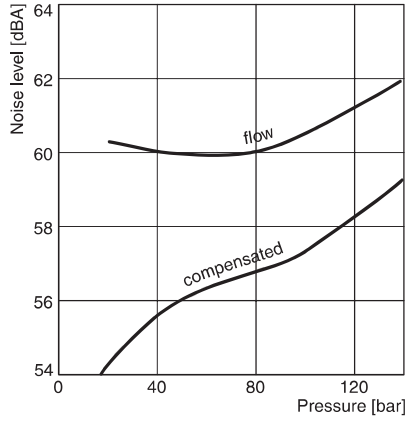

Typical noise levels for single pumps, measured in an anechoic chamber according to DIN 45 635 (microphone distance 1 m, speed  $n = 1.500$  rpm). All values measured with mineral oil at a viscosity of  $30 \text{ mm}^2/\text{s}$  and  $50^\circ \text{ C}$ .

**PVS 16 / 25**

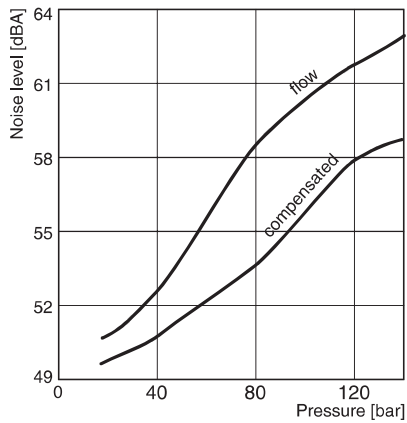

**PVS 32 / 40 / 50**

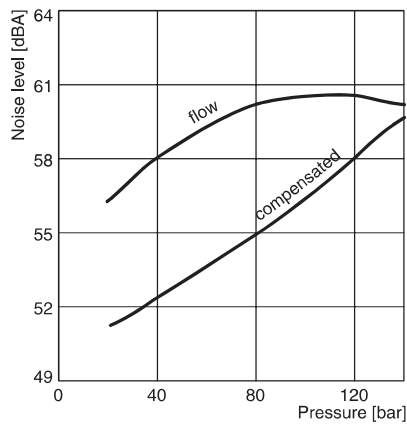

PVS.PMD RH



**PVS 08**

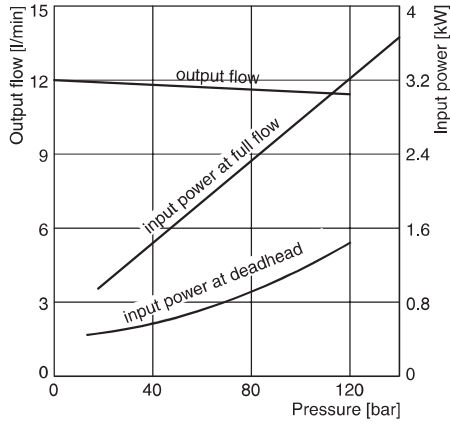

**PVS 12**

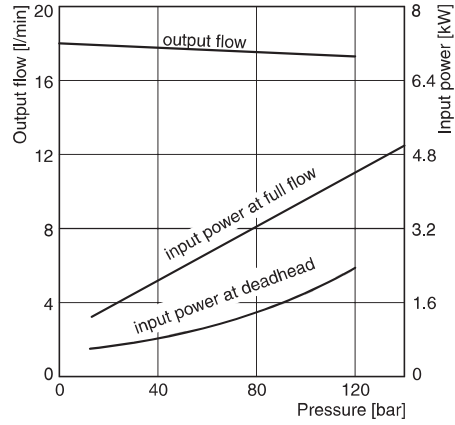

**PVS 16**

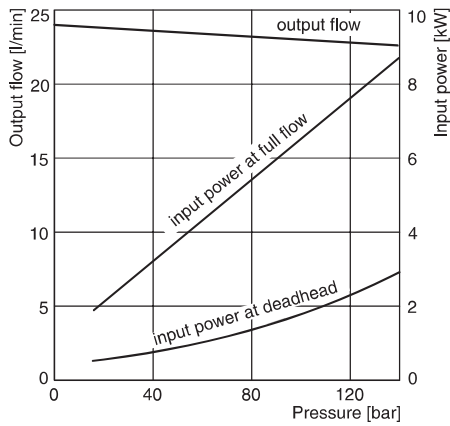

**PVS 25**

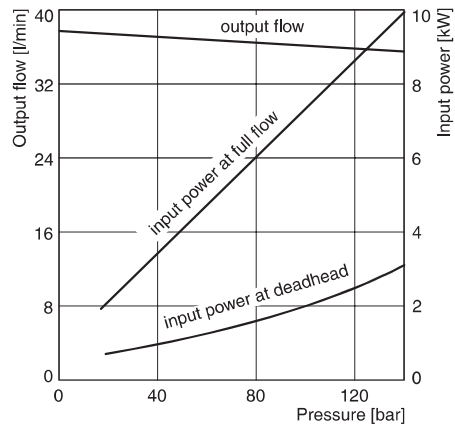

**PVS 32**

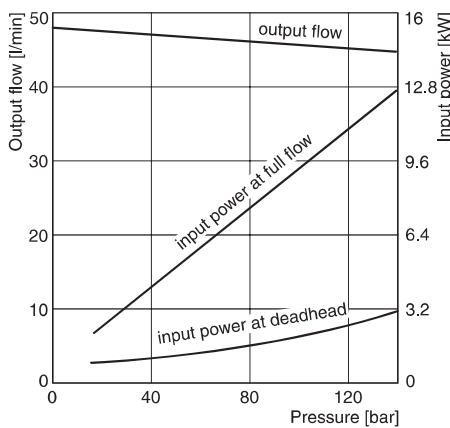

**PVS 40**

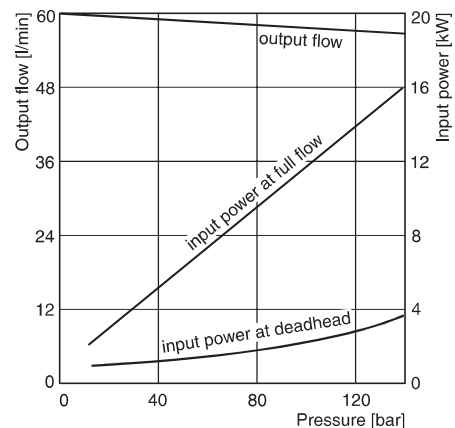

PVS,PMD RH



1

**PVS 50**

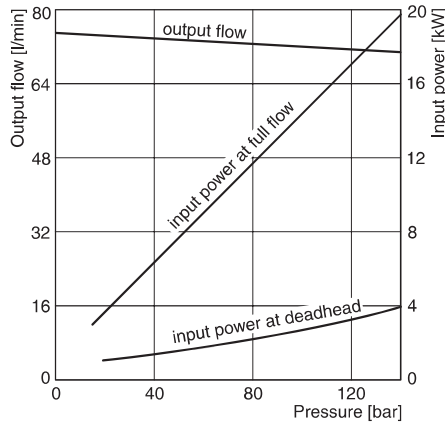

**Drain curves PVS 08 / 12**

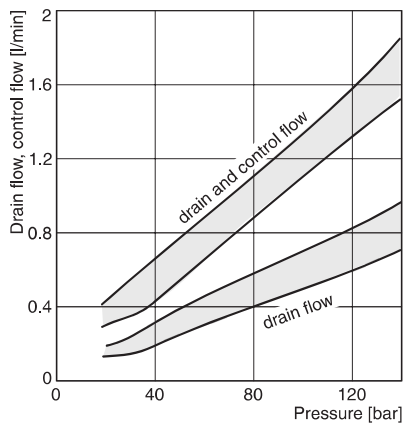

**Drain curves PVS 16 / 25**

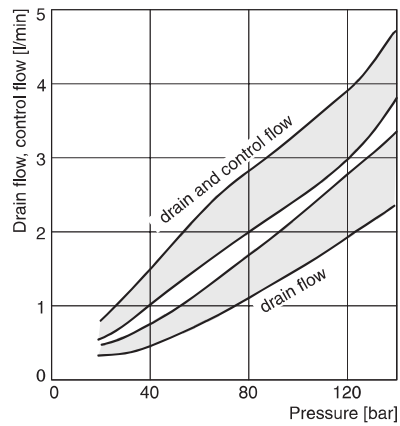

**Drain curves PVS 32 / 40 / 50**

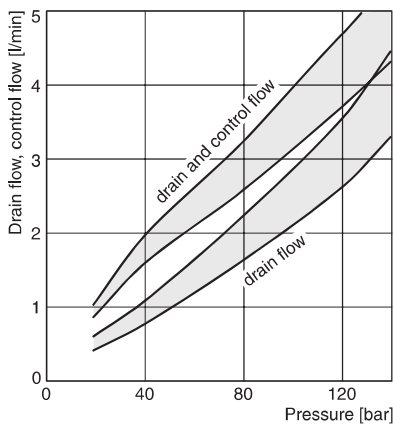

Characteristic curves determin. at speed  $n = 1500$  rpm  
 All values were measured with mineral oil at a viscosity of  $30 \text{ mm}^2/\text{s}$  and  $50^\circ \text{C}$ .

All characteristics shown are typical. They can deviate by up to 5% of the shown values depending on production tolerances of new pumps under certain conditions.

**Please note:** The values shown for drain and pilot oil apply for quasi-static operation (constant operation conditions).

During the pilot processes, significantly higher pilot oil flows can take place in short-term and can exceed 20 l/min in extreme cases. Therefore, it is absolutely necessary to set up the drain line without restrictions and as short as possible to avoid unacceptably high pressure peaks in the pump body.

PVS.PMD RH



**Dimensions**

**PVS 08 / 12, single pump**

1

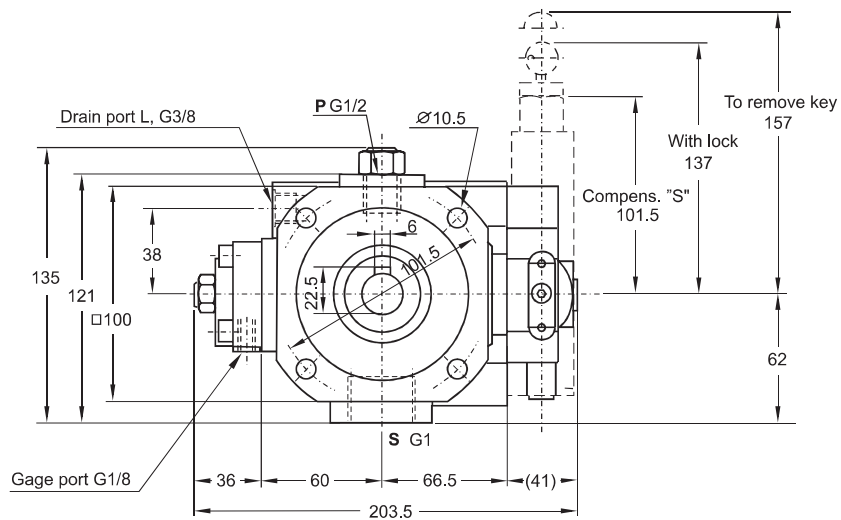
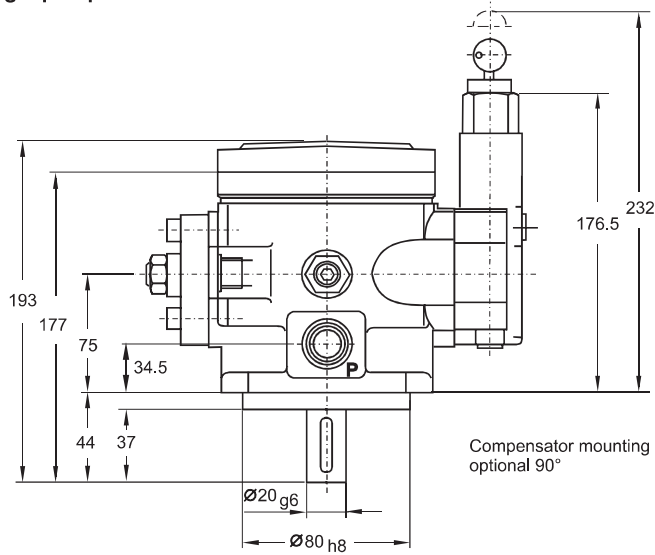

**Second pump to BG1**

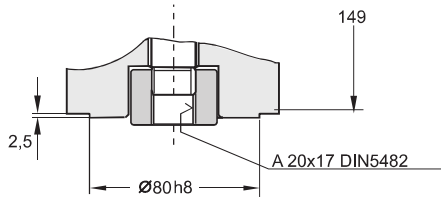

**Second pump to BG2 and BG3**

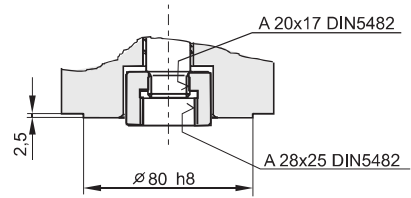

**PVS 16 / 25, single pump**

**1**

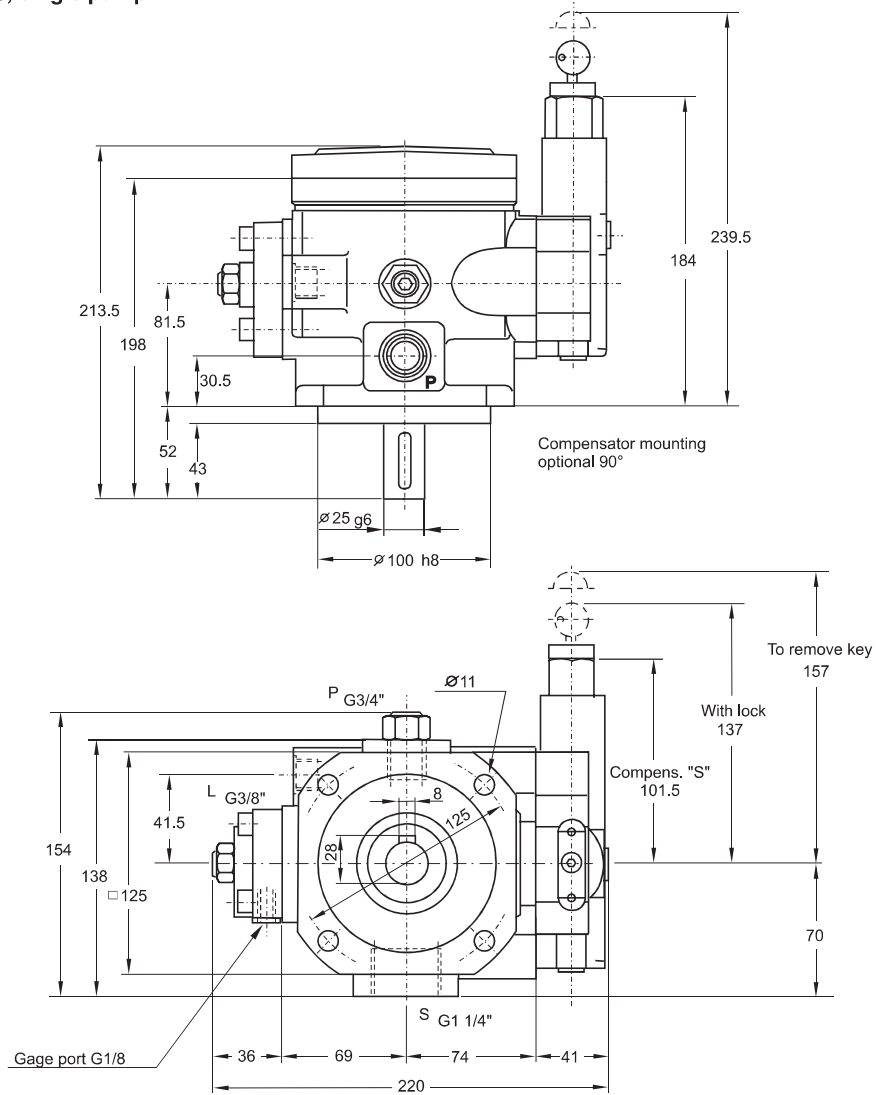

**Second pump**

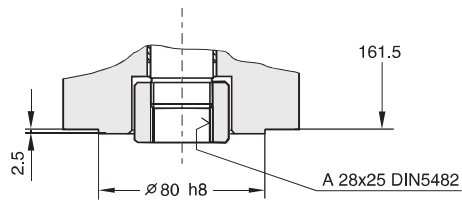

PVS.PMD RH



**Dimensions**

**PVS 32 / 40 / 50, single pump**

1

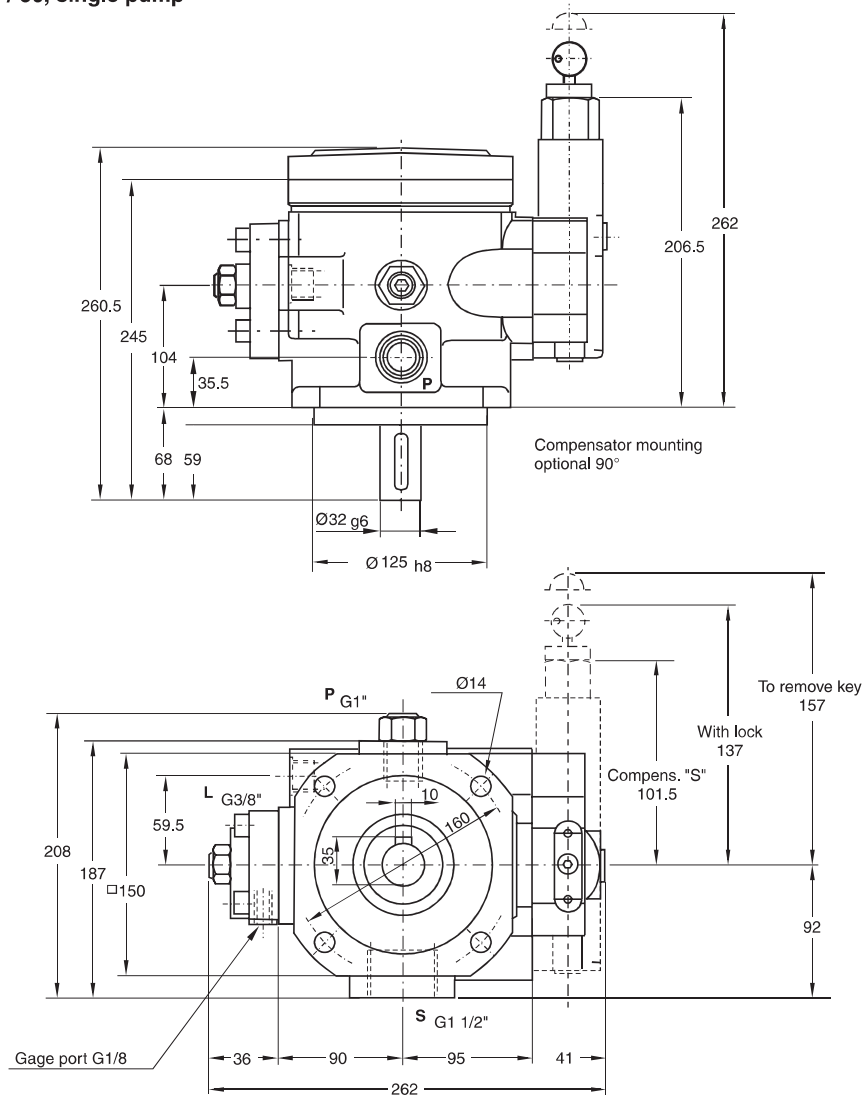

**Second pump**

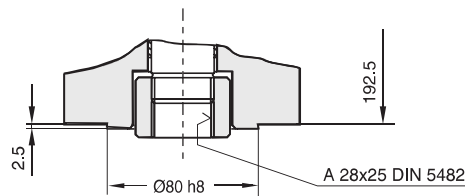

PVS,PMD RH





**Dimensions**

**Thru drive**

1

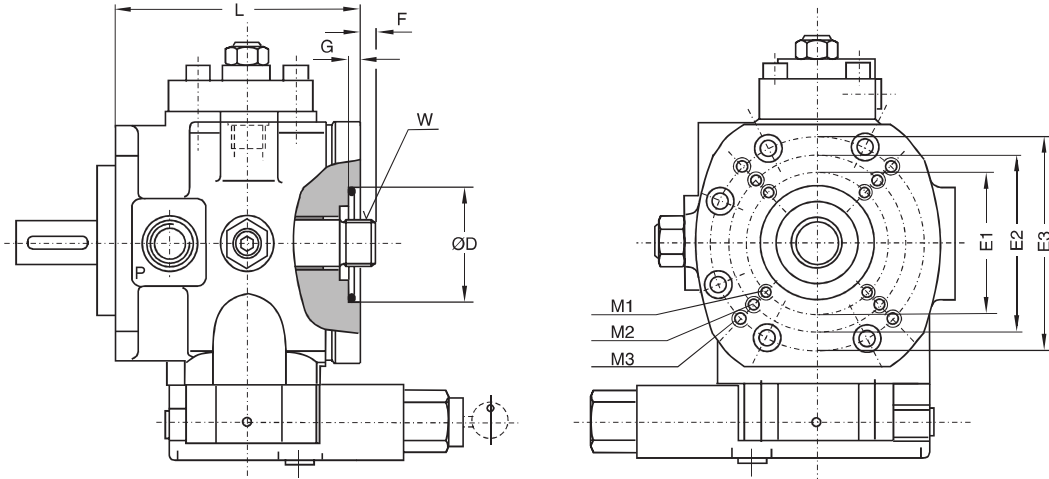

Compensator mounting optional 90°

Pump	L	D	F	G	Thru drive shaft "W"	M1	M2	M3	E1	E2	E3
PVS 08 or 12	133				B20x17 DIN 5482	M8	-	-	100	-	-
PVS 16 or 25	146	80 <sup>H7</sup>	7	4.5	B28x25 DIN 5482	M8	M10	-	100	125	-
PVS 32, 40, or 50	177				B28x25 DIN 5482	M8	M10	M12	100	125	160

**PVS pumps with thru drive**

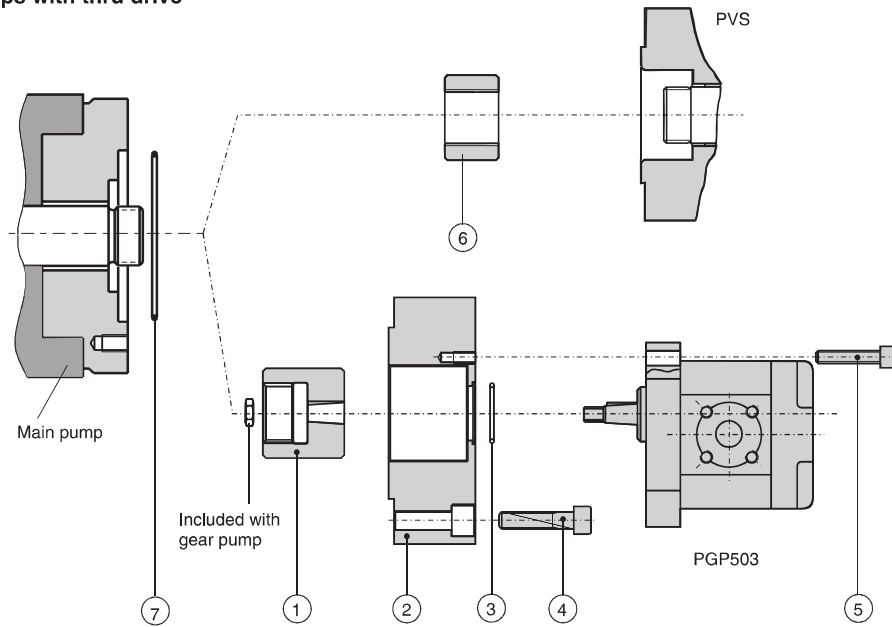

The drawing displays the mounting possibilities for Parker pumps.

**Mounting parts for pump combinations**

Main pump	Second pump	Coupling Pos.: 1	Adapter Pos.: 2	O-Ring Pos.: 3	Screw Pos.: 4	Screw Pos.: 5	Coupling Pos.: 6	O-Ring Pos.: 7
PVS 08-12	PVS 08-12	-	-	-	-	-	HR10047482	2-151-V747-75
	PGP503	HR10056670	HR10056667	HR01090121	M8x35	M6x25	-	2-151-V747-75
PVS 16-25	PVS 08-12	-	-	-	-	-	HR10047479	2-151-V747-75
	PVS 16-25	-	-	-	-	-	HR10047342	2-151-V747-75
PVS 32-50	PGP503	HR10056673	HR10056667	HR01090121	M8x35	M6x25	-	2-151-V747-75
	PVS 08-12	-	-	-	-	-	HR10047479	2-151-V747-75
	PVS 16-25	-	-	-	-	-	HR10047342	2-151-V747-75
	PVS 32-50	-	-	-	-	-	HR10047342	2-151-V747-75
	PGP503	HR10056673	HR10056667	HR01090121	M8x35	M6x35	-	2-151-V747-75

**Combinations PVS/PVS**

1

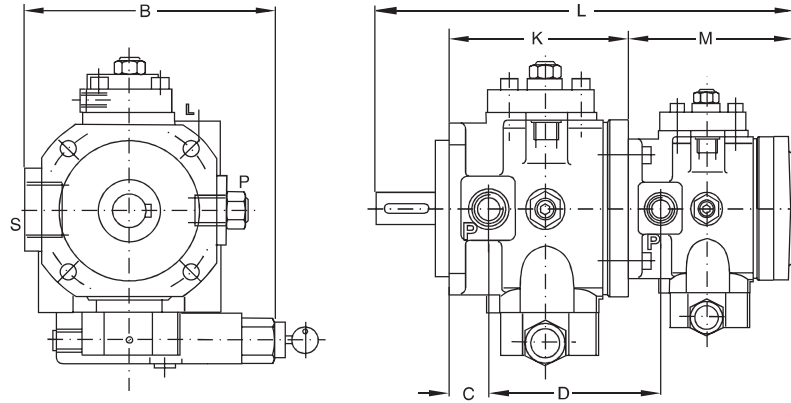

The compensators can only be mounted in the direction shown.

Main pump	Second pump	Interface main pump	B	C	K	M	D	L
PVS 08 or 12	PVS 08 or 12	80 B4 HW	163.5	34.5	133	149	133	326
PVS 16 or 25	PVS 08 or 12 PVS 16 or 25	100 B4 HW	171.5	30.5	146	149 161.5	150 146	347 359.5
* PVS 32, 40, or 50	PVS 08 or 12 PVS 16 or 25 PVS 32, 40, or 50	125 B4 HW	193.5	35.5	177	149 161.5 192.5	176 172 177	394 406.5 437.5

\* Without lock, the compensators can be optionally mounted rotated 90°, in the following combinations:  
 PVS 32/40/50 + PVS 16/25  
 PVS 32/40/50 + PVS 32/40/50

**Combinations PVS/PGP (gear pump)**

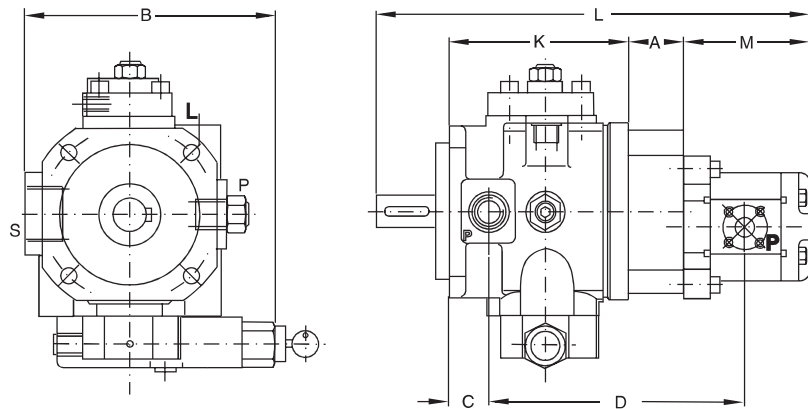

Compensator can be optionally mounted, rotated 90°.

Main pump	Second pump	Interface main pump	A	B	C	D*	K	L*	M*
PVS 08 or 12 PVS 16 or 25 PVS 32, 40, or 50	PGP503	80 B4 HW 100 B4 HW 125 B4 HW	38	162 170.5 195	34.5 30.5 35.5	174.1 - 187.1 191.1 - 204.3 217.1 - 230.3	133 146 177	290.2 - 316.5 311.2 - 337.5 358.2 - 384.5	75.2 - 101.5

\* Dimensions PGP503A0008 to PGP503A0079  
 \* For other dimensions see section PGP/PGM in this chapter.

PVS.PMD RH



**Compensator type S (PVS: Standard pressure compensator)**

The pressure is mechanically adjustable via the preload of the pilot control cartridge spring.

**Schematic diagram and performance curves**

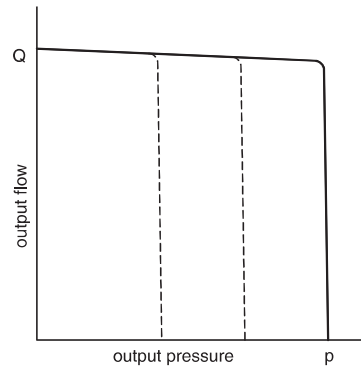
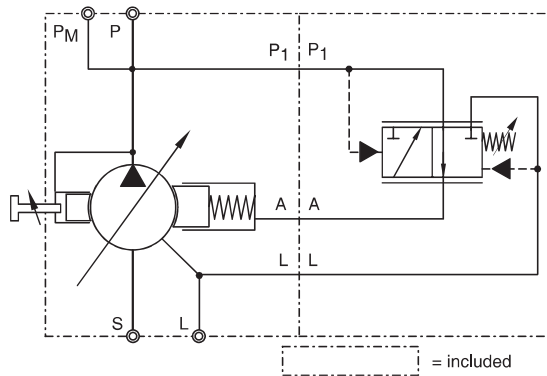

1

**Task and function**

When reaching the set pressure on the compensator, the pressure flow of the servo-controlled pump is automatically adjusted to the actual pressure flow requirement of the consumer.

Thus an undesired flow is avoided and only the required medium amount is delivered. As long as the system pressure is lower than the set pressure on the compensator, the stroke ring is kept in the position of

maximum eccentricity, so that the pump continues its full delivery. If the system pressure exceeds the set compensator pressure, the control valve opens, and the pressure on the control piston is relieved. The stroke ring is moved by the auxiliary piston up to the central position to the point where the pressure flow corresponds to the system requirements at the set pressure. The pump is regulated.

**Dimensions**

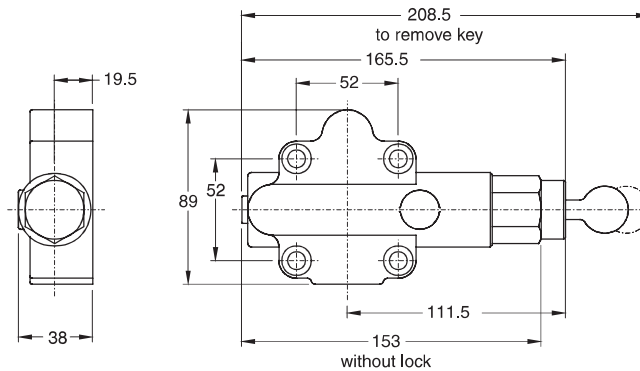

**Compensator type Y (PVY: Remote controlled pressure compensator)**

Pressure is adjustable hydraulically via pilot valve connected to Y port.

**Schematic diagram and performance curves**

1

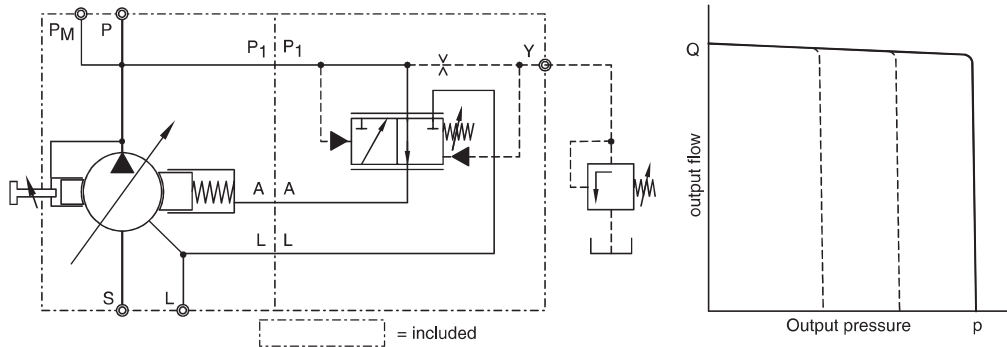

**Task and function**

The range of application for the remote control compensator is similar to the proportional compensator. The pump can be mounted in an inaccessible position (e.g. in an oil container). It is possible for the operating personnel to adjust the desired system pressure via a pressure limiting valve from a remote control desk.

It should be noted however, that the response times for the pump increase with increasing control cable length. The remote control compensator functions in principle like a pilot-operated pressure limiting valve. In contrast to the servo pressure compensator, the force contained in the equilibrium of the system pressure on the

compensator piston is applied not only by the compensator valve spool, but also by additional pressure from the spool area together with an external pilot valve (pressure limiting valve). The actual control process in the pump corresponds to that of the servo pressure compensator (an external pilot valve is not included with the pump).

**Note**

For safety reasons, the Y port of the remote control compensator must never be closed. Otherwise, the pump will not compensate.

**Dimensions**

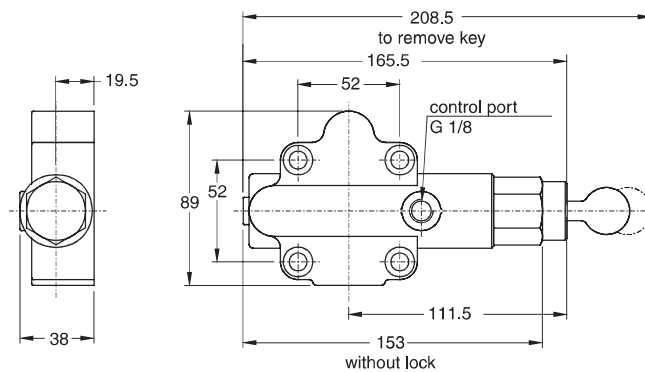

**Compensator type D, low pressure – high pressure (PVD: Two-stage pressure compensator)**

High pressure and low pressure mechanically adjustable via spring pre-loading, electric switching.

**Schematic diagram and performance curves**

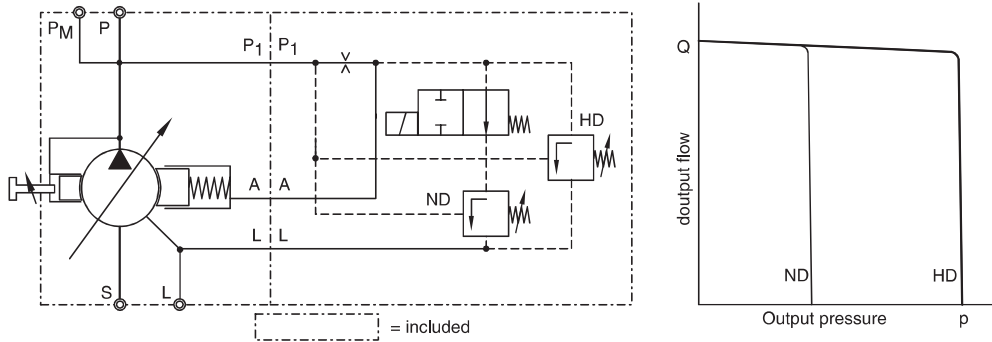

1

**Task and function**

The double pressure compensator offers the user the possibility to electrically select between two different pressures. Hydraulic systems, where a higher pressure is only needed in peaks, can be created to be very energy-saving, based on such a design. The double pressure compensator can also be labelled as a double servo pressure compensator, divided into low and high pressure stages. Both compensator pistons are connected together via an integrated directional valve.

Initially both compensator pistons are pressurised with system pressure at the unloaded directional valve. The compensator piston with the lower spring pre-loading is responsible for the system pressure. If the directional valve piston is changed over from LP to HP via electrical signal, the connection to the low pressure compensator piston is interrupted. Then, only the high pressure compensator piston is connected to the pilot oil space. The actual control process for the pump corresponds to one from a servo pressure compensator.

**Dimensions**

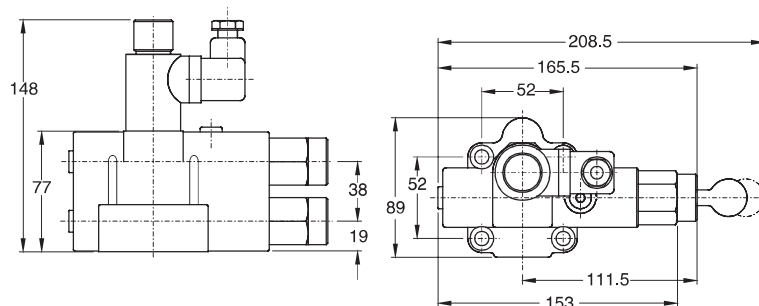

PVS,PMD RH



**Compensator type H, low pressure – high pressure (PVH: Two-stage pressure compensator)**

High pressure and low pressure mechanically adjustable via spring pre-loading, electric switching.

**Schematic diagram and performance curves**

1

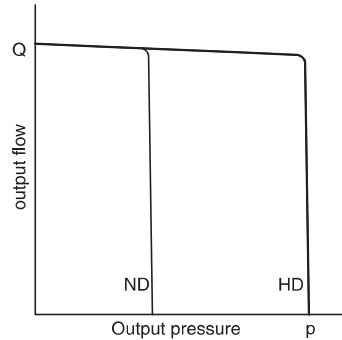
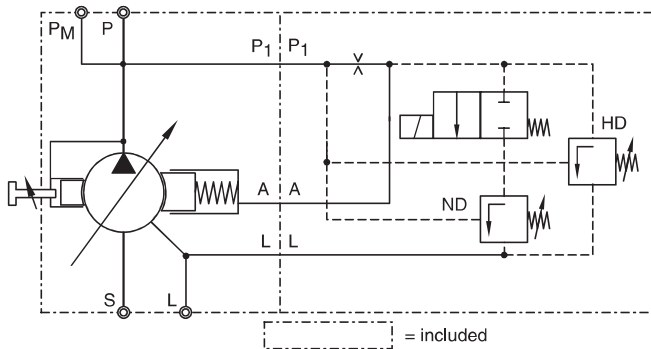

**Task and function**

The double pressure compensator offers the user the possibility to electrically select between two different pressures. Hydraulic systems, where a lower pressure is only needed for short intervals, can be created very easily, based on such a design. The double pressure compensator can also be labelled as a double servo pressure compensator, divided into low and high pressure stages. Both compensator pistons are connected together via an integrated directional valve.

Only the high pressure stage is pressurised with system pressure at the unloaded directional valve. If the directional valve piston is changed over from HP to LP via electrical signal, the connection to the low pressure compensator piston is created. Both compensator pistons are then connected with the pilot oil space. The compensator piston with the lower spring pre-loading is responsible for the system pressure. The actual control process for the pump corresponds to one from a servo pressure compensator.

**Dimensions**

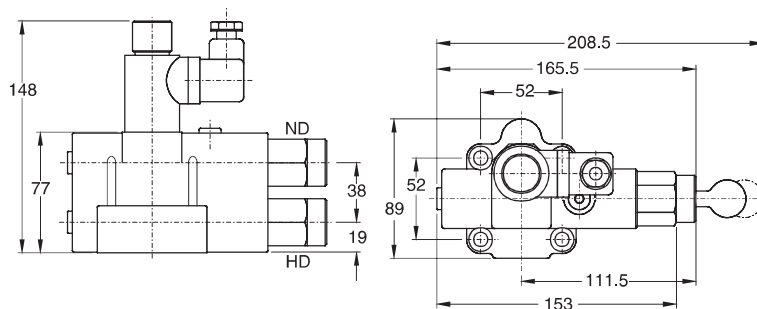

PVS.PMD RH



**Compensator type M, pressure flow compensator (PVM: Pressure flow compensator)**

Flow adjustable via main stream throttle valve, load pressure independent flow control, no internal pressure compensation.

**Schematic diagram and performance curves**

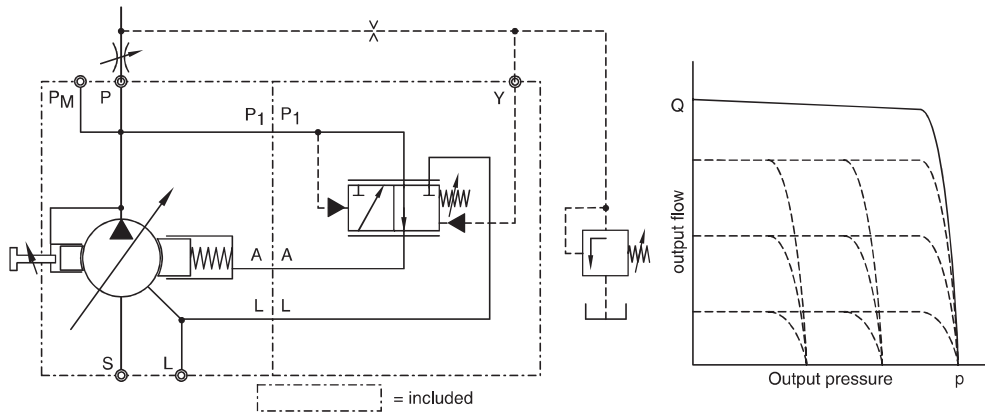

**1**

**Task and function**

The pressure flow compensator is responsible to keep the pressure flow of the pump to the metering position (orifice, choke, proportional valve, etc.) constant despite fluctuations in load and input speed. However, it must be remembered that this compensation is not possible at  $Q_{max}$ . To ensure proper control behaviour, a maximum of approx.  $2/3 Q_{max}$  should be worked with. The necessary constant pressure differential is achieved for constant flow at the metering position by directing both pressures

(pressure before and after the metering position) on to the compensator piston, such that the lower pressure (pressure behind the metering position) with the compensator valve spool works against the pump pressure (2 way pressure compensator function). (Throttle and external pressure limiting valve are not included with the pump).

**Note**

When using the pressure flow compensator, max. pressure protection via an external pressure limiting valve is absolutely necessary. Otherwise, the pump will not compensate.

**Dimensions**

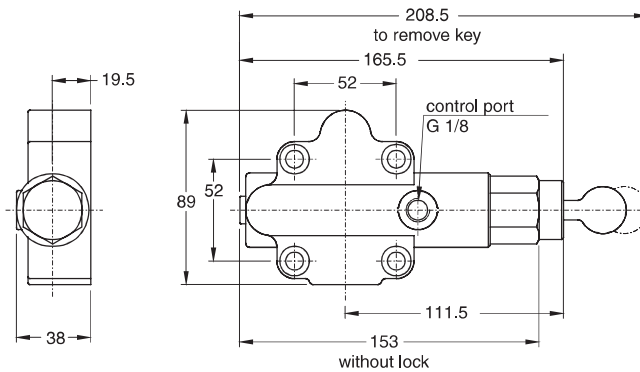

PVS,PMD RH



**Compensator type K, pressure flow pressure compensator (PVK: Pressure flow pressure compensator)**

Flow adjustable via main stream throttle valve, pressure mechanically adjustable via pre-load spring, load pressure independent flow control.

**Schematic diagram and performance curves**

**1**

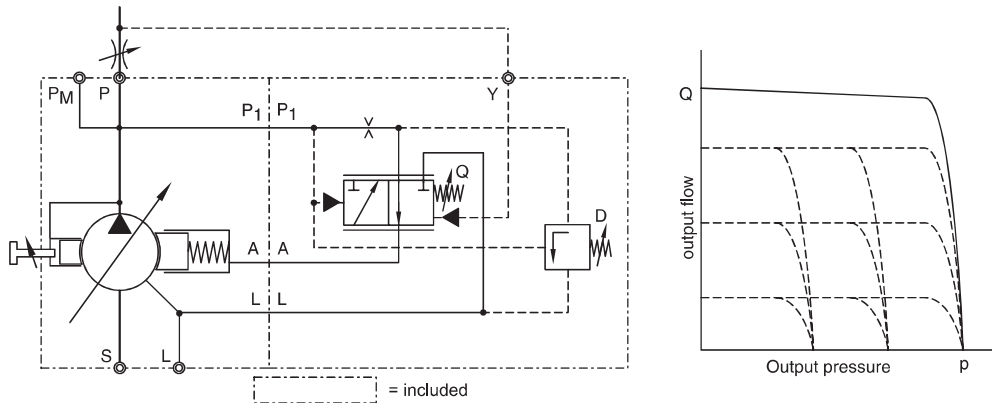

**Task and function**

The pressure flow - pressure compensator is a compensation device that was specially designed for use in load sensing systems. The displacement control is executed dependent on load, i.e. the optimal ratio of pressure and flow are set independent of pending load pressure on the consumer (e.g. hydro-motor). A characteristic feature of all load sensing compensators is the feedback of the load pressure (Y). In systems with variable load pressures, this control is characterised by the energetic and functional superiority compared to conventional compensators. On the compensator are two basic

system-dependant settings undertaken, the setting for the differential pressure (Dp) necessary for the pressure flow (Q) and the setting of the maximum pressure (D). The setting (Q) is a result of the differential pressure (Dp) with which a metering position is flow through (orifice, choke, proportional valve, etc.). If the load pressure is altered at the consumer or the pressure in the feedback (Y), the pump decreases or increases its pressure until the differential pressure set on (Q) is reached again (2 way pressure compensator function). This process takes place continuously, up until the pressure set on (D) is reached.

**Dimensions**

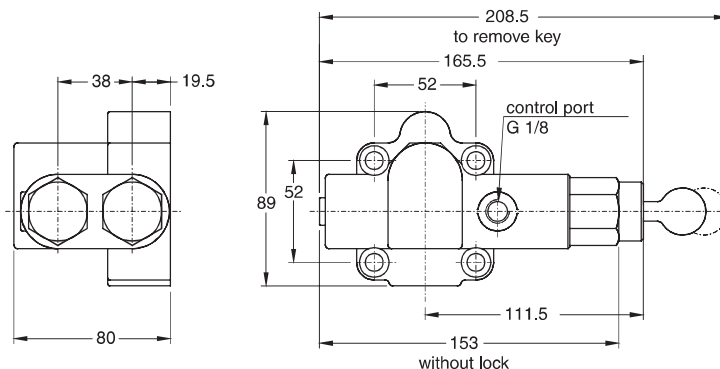

PVS.PMD RH



**Compensator type L, proportional pressure compensator (PVL: Proportional pressure compensator)**

Pressure can be adjusted electrically using a proportional solenoid and control electronics.

**Schematic diagram and performance curves**

1

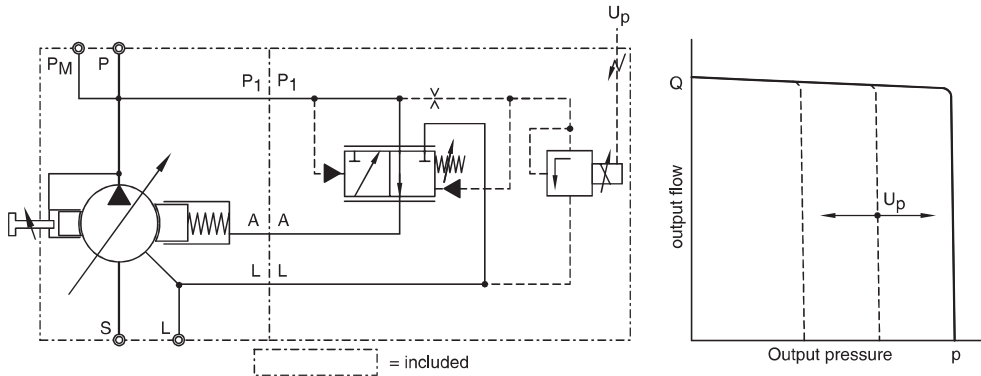

**Task and function**

The range of application for the proportional compensator is similar to the remote control compensator. The pump can be mounted in an inaccessible position. It is possible for the operating personnel to adjust the desired system pressure from a remote control desk, manually or by a program. Further advantages are the controllable process of the

transition between various command settings, the reproducibility of the control pressure, and fast response times. The principle of the proportional compensator is similar to the servo pressure compensator. Setting the pressure does not take place at the compensator, but instead through infinitely variable control via a pilot valve with proportional solenoid.

**Dimensions**

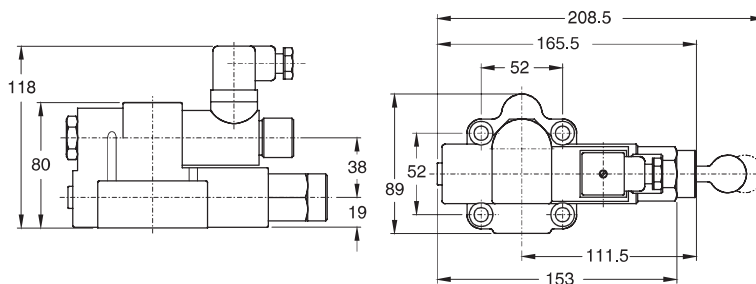

PVS,PMD RH



**Bell housing, coupling and foot flange**

**1**

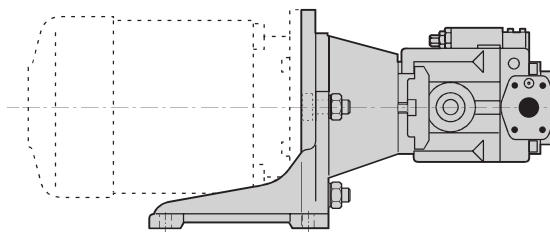
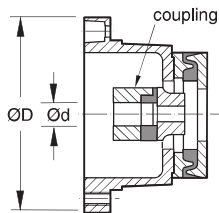
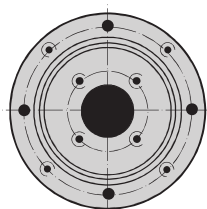

Can be purchased at:

**Raja**  
Rahmer + Jansen GmbH  
Vorthstr. 1  
58775 Werdohl, Germany  
phone: +49 (0) 2392-5090, fax: +49 (0) 2392-4966

or **KTR**  
Kupplungstechnik GmbH  
Rodder Damm  
48432 Rheine, Germany  
phone: +49 (0) 5971-7980, fax: +49 (0) 5971-798443

**Pressure, suction and drain port**

For more information about connections please see Parker Tube Fittings Catalogue 4100-6/UK by:

**Parker Hannifin GmbH**  
**Tube Fittings Division**  
Am Metallwerk 9  
33659 Bielefeld, Germany  
phone: +49 (0) 521-40480, fax: +49 (0) 521-4048280

**Fluid recommendations**

Premium quality hydraulic mineral oil fluids are recommended, like H-LP oils to DIN 51524, part 2. The viscosity range should be 25 to 50 mm<sup>2</sup>/s (cSt) at 50 °C.

Normal operating viscosity range between 12 and 100 mm<sup>2</sup>/s (cSt). Maximum start-up viscosity is 800 mm<sup>2</sup>/s (cSt). Operating temperature -30 to + 70 °C.

For other fluids such as phosphoric acid esters or for other operating conditions consult your Parker representative for assistance.

**Seals**

NBR (nitrile) seals are used for operation with hydraulic fluids based on mineral oil. For synthetic fluids, as perhaps phosphoric acid esters, Fluorocarbon seals are required. Consult your Parker representative for assistance.

**Filtration**

For maximum pump and system component functionability and life, the system should be protected from contamination by effective filtration.

Fluid cleanliness should be in accordance with ISO classification ISO 4406:1999. The quality of filter elements should be in accordance with ISO standards.

**Minimum requirement for filtration rate x (mm):**

General hydraulic systems for satisfactory operation:

Class 20/18/15, to ISO 4406:1999

**Hydraulic systems with maximised component life and functionability:**

Class 18/16/13, to ISO 4406:1999

It is recommended to use return line or pressure filters. Parker Filter Division offers a wide range of these filters for all common applications and mounting styles. The use of suction filters should be avoided, especially with fast response pumps. Bypass filtration is a good choice for best filter efficiency.

**Installation and mounting**

**Horizontal mounting:** Outlet port side or top. Inlet port side or bottom, drain port always uppermost.

**Vertical mounting:** Shaft pointing upwards.

Install pump and suction line in such a way that the maximum inlet pressure never exceeds 0.8 bar absolute. The inlet line should be as short and as straight as possible. A short suction line cut to 45° is recommended when the pump is mounted inside the reservoir, to improve the inlet conditions. All connections to be leak-free, as air in the suction line will cause cavitation, noise, and damage to the pump.

**Drain port**

Compensation may cause short-term (20 to 30 ms) flow increase, e.g. 30 l/min (PV 016 to 023), 40 l/min (PV 032 to 046), 60 l/min (PV 063 to 092), 80 l/min (PV 140 to 180) and/or 120 l/min (PV270). Please consider for dimensioning.

**Drain line**

The drain line must lead directly to the reservoir without restriction. The drain line must not be connected to any other return line. The end of the drain line must be below the lowest fluid level in the reservoir and as far away as possible from the pump inlet line. This ensures that the pump does not empty itself when not in operation and that hot airtreated oil will not be recirculated.

For the same reason, when the pump is mounted inside the reservoir, the drain line should be arranged in such a way that a siphon is created. This ensures that the pump is always filled with fluid. The drain pressure must not exceed 2 bar. Drain line length should not exceed 2 metres. Minimum diameter should be selected according to the port size and a straight low pressure fitting with maximised bore should be used.

**Shaft rotation and alignment**

Pump and motor shafts must be aligned within 0.25mm T.I.R. maximum. A floating coupling must be used. Bellhousings and couplings can be ordered at manufacturers listed in this catalogue. Please follow the coupling manufacturer's installation instructions. Consult your Parker representative for assistance on radial load type drives.

**Start up**

Prior to start up, the pump case must be filled with hydraulic fluid (use case drain port). Initial start up should be at zero pressure with an open circuit to enable the pump to prime. Pressure should only be increased once the pump has been fully primed.

**Attention: Check motor rotation direction.**

For more details see PVS pump installation manual HY11-AL332-M1/UK.