

157R9915

157R9915

### Hirschmann versions:

Oliestrømmens retning for standard monterede grupper.

Oil flow direction for standard assembled groups.

Richtung des Ölstroms für Standard-Baugruppen.

Sens du débit pour ensembles standard.

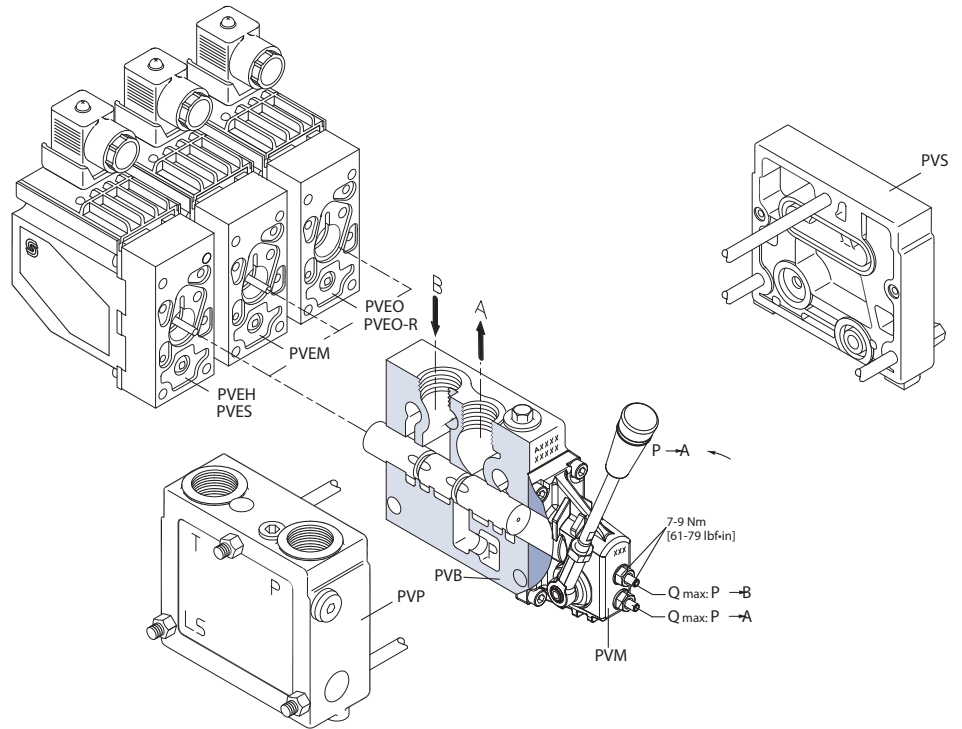

V310117.A

### AMP versions:

Oliestrømmens retning for standard monterede grupper.

Oil flow direction for standard assembled groups.

Richtung des Ölstroms für Standard-Baugruppen.

Sens du débit pour ensembles standard.

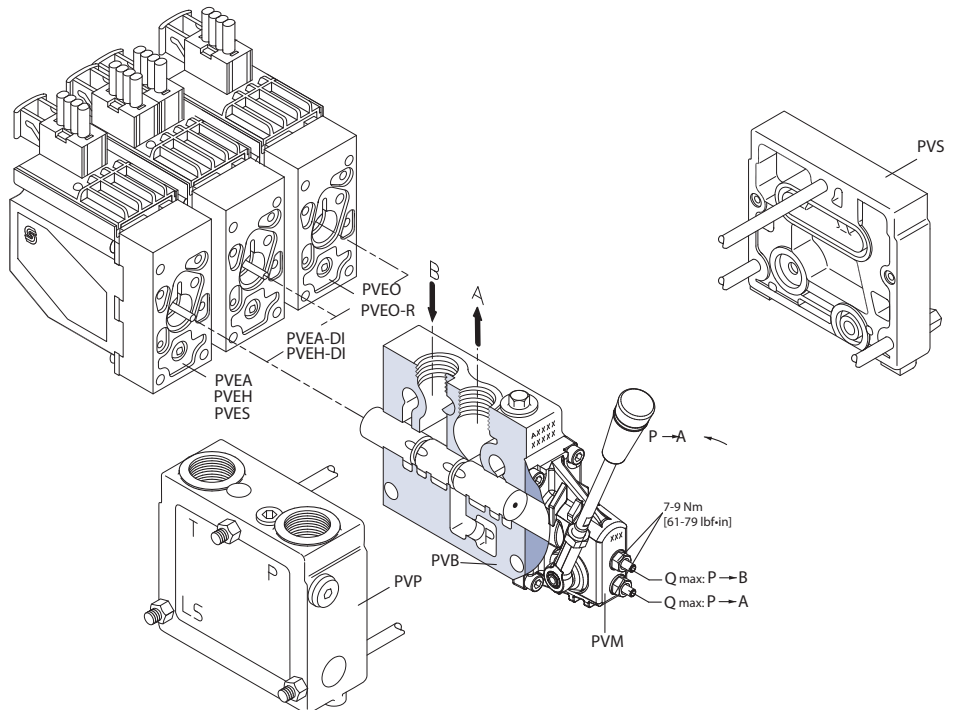

V310118.A

**Deutsch versions:**

Oliestrømmens retning for standard monterede grupper.

Oil flow direction for standard assembled groups.

Richtung des Ölstroms für Standard-Baugruppen.

Sens du débit pour ensembles standard.

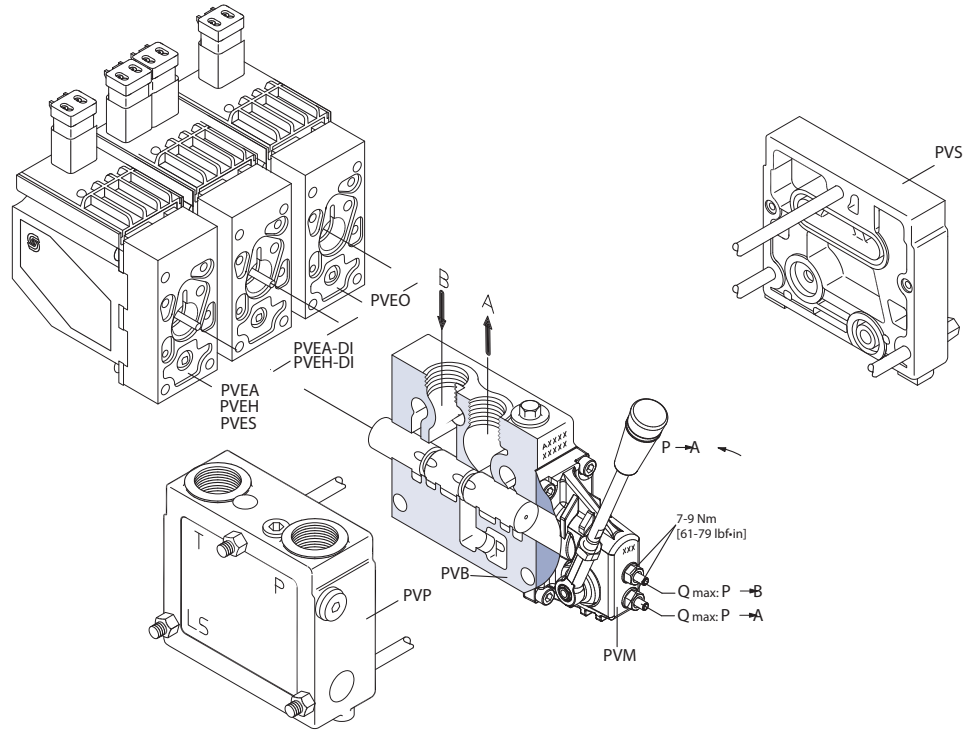

V310119.A

**AMP version on/off**

Function	Signal voltage (A or B)	
	A (pin 1)	B (pin 2)
Neutral	0	0
Q: P -> A	$U_{DC}$	0
Q: P -> B	0	$U_{DC}$

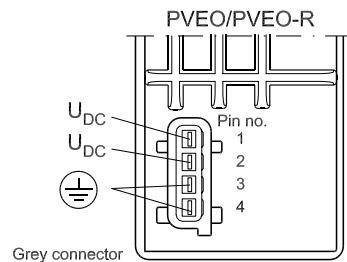

157-498.12

**AMP version proportional**

Function	Signal voltage ( $U_S$ )
Neutral	$U_S$ (pin 1) = $0.5 \cdot U_{DC}$
Q: P -> A	$U_S$ (pin 1) = $(0.5 \rightarrow 0.25) \cdot U_{DC}$
Q: P -> B	$U_S$ (pin 1) = $(0.5 \rightarrow 0.75) \cdot U_{DC}$

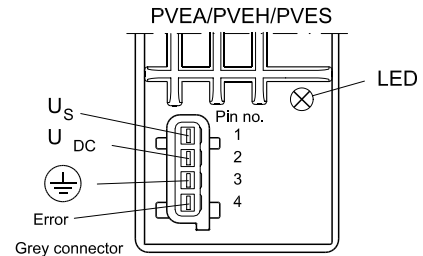

157-500.10

Til DI udførelserne er det nødvendigt at have 2  $U_{DC}$ -tilslutninger ( $U_{DC}$  og  $U_{DC2}$ ):

- $U_{DC2}$  forsyner elektronikken og
- $U_{DC}$  forsyner magnetventilerne

De to jordforbundne stikben (mærket 3) er internt forbundet.

Der kan med fordel anvendes to separate strømforsyninger (jvf. tekniske informationer for PVE serie 4)

On DI versions two UDC connections (UDC and UDC2) are necessary.

- $U_{DC2}$  will supply the electronics and
- $U_{DC}$  will supply the solenoid valves

The two ground pins (pin 3) are internally connected.

With advantages two separate power supplies can be used, see also Technical information for PVE series 4.

Die DI Ausführungen fordern zwei  $U_{DC}$ -Anschlüsse ( $U_{DC}$  und  $U_{DC2}$ ):

- $U_{DC2}$  versorgt die Elektronik und
- $U_{DC}$  versorgt die Magnetventile

De zwei Erdungsstecker (vermerkt 3) sind intern verbunden.

Es kann mit Vorteil zwei separate Stromversorgungen verwendet werden (vgl. technische Informationen für PVE Serie 4)

Pour les versions DI deux raccordements  $U_{DC}$  ( $U_{DC}$  et  $U_{DC2}$ ) sont nécessaires.

- $U_{DC2}$  alimente l'électronique
- $U_{DC}$  alimente les électro-distributeurs

Les deux bornes masse (borne 3) sont reliées intérieurement

L'emploi de deux sources d'alimentation séparées a des avantages, voir Information Technique pour PVE série 4

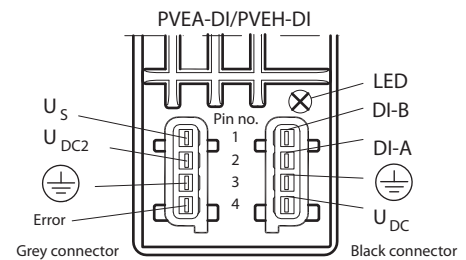

P301 106

**Hirschmann version on/off**

Function	Signal voltage (A or B)	
	A (pin 1)	B (pin 2)
Neutral	0	0
Q: P -> A	$U_{DC}$	0
Q: P -> B	0	$U_{DC}$

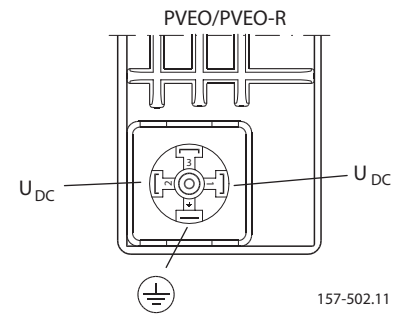

157-502.11

**Hirschmann version proportional**

Function	Signal voltage ( $U_S$ )
Neutral	$U_S$ (pin 2) = $0.5 \cdot U_{DC}$
Q: P -> A	$U_S$ (pin 2) = $(0.5 \rightarrow 0.25) \cdot U_{DC}$
Q: P -> B	$U_S$ (pin 2) = $(0.5 \rightarrow 0.75) \cdot U_{DC}$

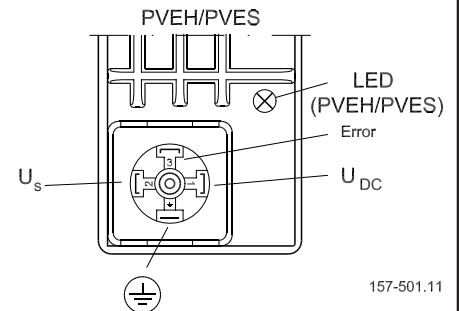

157-501.11

**Deutsch version on/off**

Function	Signal voltage (A or B)
	A (pin 1)   B (pin 4)
Neutral	0   0
Q: P -> A	$U_{DC}$   0
Q: P -> B	0   $U_{DC}$

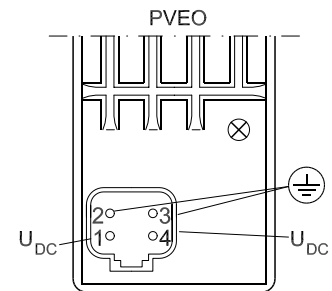

157-760.12

**Deutsch version proportional**

Function	Signal voltage ( $U_S$ )
Neutral	$U_S$ (pin 1) = $0.5 \cdot U_{DC}$
Q: P -> A	$U_S$ (pin 1) = $(0.5 \rightarrow 0.25) \cdot U_{DC}$
Q: P -> B	$U_S$ (pin 1) = $(0.5 \rightarrow 0.75) \cdot U_{DC}$

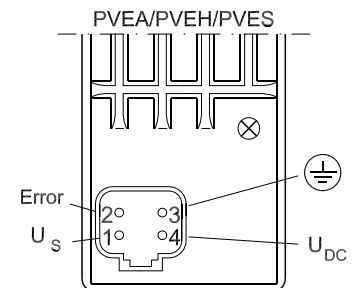

157-759.11

Til DI udførelserne er det nødvendigt at have 2  $U_{DC}$ -tilslutninger ( $U_{DC}$  og  $U_{DC2}$ ):

- $U_{DC}$  forsyner elektronikken og
- $U_{DC2}$  forsyner magnetventilerne

De to jordforbundne stikben er internt forbundet.

Der kan med fordel anvendes to separate strømforsyninger (jvf. tekniske informationer for PVE serie 4)

On DI versions two  $U_{DC}$  connections ( $U_{DC}$  and  $U_{DC2}$ ) are necessary.

- $U_{DC}$  will supply the electronics and
- $U_{DC2}$  will supply the solenoid valves

The two ground pins are internally connected.

With advantages two separate power supplies can be used, see also Technical information for PVE series 4.

Die DI Ausführungen fordern zwei  $U_{DC}$ -Anschlüsse ( $U_{DC}$  und  $U_{DC2}$ ):

- $U_{DC}$  versorgt die Elektronik und
- $U_{DC2}$  versorgt die Magnetventile

Die zwei Erdungsstecker sind intern verbunden.

Es kann mit Vorteil zwei separate Stromversorgungen verwendet werden (vgl. technische Informationen für PVE Serie 4)

Pour les versions DI deux raccordements  $U_{DC}$  ( $U_{DC}$  et  $U_{DC2}$ ) sont nécessaires.

- $U_{DC}$  alimente l'électronique
- $U_{DC2}$  alimente les électrodistributeurs

Les deux bornes masse sont reliées intérieurement

L'emploi de deux sources d'alimentation séparées a des avantages, voir Information Technique pour PVE série 4

**Deutsch version  
proportional**

Function	Signal voltage ( $U_S$ )
Neutral	$U_S$ (pin 1) = $0.5 \cdot U_{DC}$
Q: P -> A	$U_S$ (pin 1) = $(0.5 \rightarrow 0.25) \cdot U_{DC}$
Q: P -> B	$U_S$ (pin 1) = $(0.5 \rightarrow 0.75) \cdot U_{DC}$

**Deutsch-version  
DI-function**

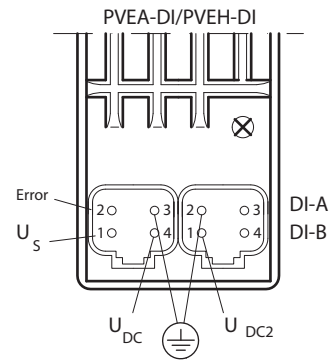

P301 105

**Deutsch version  
proportional**

Function	Signal voltage ( $U_S$ )
Neutral	$U_S$ (pin 1) = $0.5 \cdot U_{DC}$
Q: P -> A	$U_S$ (pin 1) = $(0.5 \rightarrow 0.25) \cdot U_{DC}$
Q: P -> B	$U_S$ (pin 1) = $(0.5 \rightarrow 0.75) \cdot U_{DC}$

**Deutsch-version  
SP-function**

Function	SP output signal
Neutral	$U_{SP}$ (pin 4) = 2.5 V
Q: P -> A	$U_{SP}$ (pin 4) = 2.5 -> 1.25 V
Q: P -> B	$U_{SP}$ (pin 4) = 2.5 -> 3.75 V

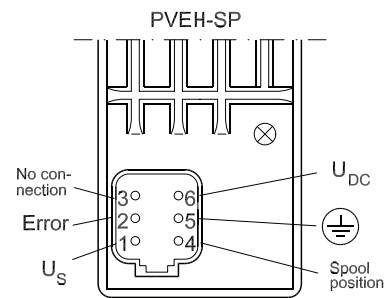

157-800.11

Til DI udførelserne er det nødvendigt at have 2  $U_{DC}$ -tilslutninger ( $U_{DC}$  og  $U_{DC2}$ ):

- $U_{DC}$  forsyner elektronikken og
- $U_{DC2}$  forsyner magnetventilerne

De to jordforbundne stikben er internt forbundet.

Der kan med fordel anvendes to separate strømforsyninger (jvf. tekniske informationer for PVE serie 4)

On DI versions two UDC connections (UDC and UDC2) are necessary.

- $U_{DC}$  will supply the electronics and
- $U_{DC2}$  will supply the solenoid valves

The two ground pins are internally connected.

With advantages two separate power supplies can be used, see also Technical information for PVE series 4.

Die DI Ausführungen fordern zwei  $U_{DC}$ -Anschlüsse ( $U_{DC}$  und  $U_{DC2}$ ):

- $U_{DC}$  versorgt die Elektronik und
- $U_{DC2}$  versorgt die Magnetventile

De zwei Erdungsstecker sind intern verbunden.

Es kann mit Vorteil zwei separate Stromversorgungen verwendet werden (vgl. technische Informationen für PVE Serie 4)

Pour les versions DI deux raccordements  $U_{DC}$  ( $U_{DC}$  et  $U_{DC2}$ ) sont nécessaires.

- $U_{DC}$  alimente l'électronique
- $U_{DC2}$  alimente les électrodistributeurs

Les deux bornes masse sont reliées intérieurement

L'emploi de deux sources d'alimentation séparées a des avantages, voir Information Technique pour PVE série 4

## Technical data

Følgende tekniske data bygger på typiske testresultater. Der anvendes mineralsk olie med en viskositet på 21 mm<sup>2</sup>/s (102 SUS) og en temperatur på 50°C (122°F).

The following technical data are from typical test results. For the hydraulic system a mineral based hydraulic oil with a viscosity of 21 mm<sup>2</sup>/s [102 SUS] and a temperature of 50° C [122° F] were used.

Følgende teknische Daten bauen auf typische Testergebnisse. Es wurde Erdöl mit einer Viskosität von 21 mm<sup>2</sup>/s (102 SUS) und einer Temperatur von 50°C (122°F) verwendet.

Les caractéristiques techniques suivantes sont tirées de résultats de tests typiques. Pour le système hydraulique, on a utilisé une huile minérale d'une viscosité de 21 mm<sup>2</sup>/s [102 SUS] et à une température de 50° C [122° F].

		PVEO and PVEM	
Supply voltage U <sub>DC</sub>	rated	12 V DC	24 V DC
	range	11 V to 15 V	22 V to 30 V
	max. ripple	5%	
Current consumption at rated voltage		0.65 A @ 12 V	0.33 A @ 24 V
Signal voltage (PVEM)	neutral	0.5 x U <sub>DC</sub>	
	A-port ↔ B-port	0.25 • U <sub>DC</sub> to 0.75 • U <sub>DC</sub>	
Signal current at rated voltage (PVEM)		0.25 mA	0.50 mA
Input impedance in relation to 0.5 • U <sub>DC</sub>		12 KΩ	
Power consumption		8 W	

### PVEA, PVEH and PVES

		PVEA, PVEH and PVES	
Supply voltage U <sub>DC</sub>	rated	11 V to 32 V	
	range	11 V to 32 V	
	max. ripple	5%	
Current consumption at rated voltage	PVEH/PVES (PVEA)	0.57 (0.28) A @ 12 V	0.3 (0.15) A @ 24 V
Signal voltage	neutral	0.5 x U <sub>DC</sub>	
	A-port ↔ B-port	0.25 • U <sub>DC</sub> to 0.75 • U <sub>DC</sub>	
Signal current at rated voltage		0.25 mA to 0.70 mA	
Input impedance in relation to 0.5 • U <sub>DC</sub>		12 KΩ	
Input capacitor		100 nF	
Power consumption	PVEH/PVES (PVEA)	7 (3.5) W	

### Oil viscosity

Oil viscosity	range	12 - 75 mm <sup>2</sup> /s [65 - 347 SUS]
	min.	4 mm <sup>2</sup> /s [39 SUS]
	max.	460 mm <sup>2</sup> /s [2128 SUS]

Bemærk: Maksimum opstartviskositet  
 Note: Max. start up viscosity 2500 mm<sup>2</sup>/s  
 Beachte: Maximale Viskosität bei Inbetriebnahme  
 Remarque: Viscosité maximale au démarrage 2500 mm<sup>2</sup>/s

### Oil temperature

Oil temperature	range	30 - 60°C [86 - 140°F]
	min.	-30°C [-22°F]
	max.	90°C [194°F]

### Filtering

Filtering in the hydraulic system	Max. allowed degree of contamination (ISO 4406, 1999 version): 18/16/13
-----------------------------------	---

### Pilot pressure

Pilot pressure (relative to T pressure)	nom.	13.5 bar [196 psi]
	min.	10 bar [145 psi]
	max.	15 bar [217 psi]

### Version with Hirschmann connector

Grade of enclosure *	IP 65
----------------------	-------

\* According to the international standard IEC 529

### Version with AMP JPT connector

Grade of enclosure *	IP 66
----------------------	-------

### Version with Deutsch connector

Grade of enclosure *	IP 66
----------------------	-------

Bemærk: I særligt udsatte maskiner anbefales der beskyttelse i form af screening  
 Beachte: In besonders ausgesetzten Maschinen wird Schutz in Form von elektrischer Abschirmung empfohlen.  
 NB: In particularly exposed applications, protection in the form of screening is recommended.  
 Remarque: Pour les applications particulièrement exposées, il est recommandé d'installer une protection par écran.

## Direction indicator

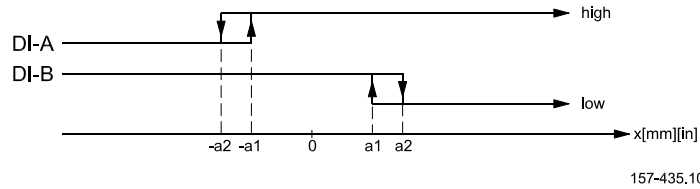

	A-port	B-port
Direction signals "a1", "a2"	-0.8 ± 0.4 mm [0.031 ± 0.015 in]	0.8 ± 0.4 mm [0.031 ± 0.015 in]
Max. load of "Dir_A", "Dir_B"	50 mA	
Voltage "High" value with load of "Dir_A" or "Dir_B" = 20 mA	Minimum: U <sub>DC</sub> - 1.5 V	
Voltage "High" value with load of "Dir_A" or "Dir_B" = 50 mA	Minimum: U <sub>DC</sub> - 2.0 V	
Voltage "Low" value	Maximum: 0.2 V	

As shown in the figure, both "Dir\_A" and "Dir\_B" signals are "High" when the spool is in Neutral position. When the spool is moving in the A direction, the "Dir\_A" signal goes "Low" and the "Dir\_B" signal stays "High". The reverse is true when the spool is moved in the B direction.

Type	Fault monitoring	Delay before error out	Error mode	Error output status	Fault output on PVE 1)	LED light	Memory (reset needed)
PVEO PVEM	No fault monitoring	-	-	-	-	-	-
PVEA PVEH PVES	Active	500 ms (PVEA: 750ms)	No fault	Low	< 2 V	Green	-
			Input signal faults	High	~U <sub>DC</sub>	Flashing red	Yes
			Transducer (LVDT)			Constant red	
	Close loop fault	High	~U <sub>DC</sub>	Constant red	No		
	Passive	250 ms (PVEA: 750ms)	No fault	Low	< 2 V	Green	-
			Input signal faults	High	~U <sub>DC</sub>	Flashing red	No
Transducer (LVDT)			Constant red				
Close loop fault	High	~U <sub>DC</sub>	Constant red	No			

<sup>1)</sup> Measured between fault output pin and ground

### ⚠ WARNING

Alle mærker og typer af retningsventiler – også proportional ventiler – kan svigte og forårsage alvorlig skade. Det er derfor vigtigt at analysere maskinen i alle enkeltheder. Da proportionalventiler anvendes under mange forskellige driftsbetingelser og i mange forskellige maskiner, er det alene maskinproducentens ansvar at træffe det endelige produktvalg og sikre at samtlige maskinens krav til ydelse, sikkerhed og advarsler er opfyldt. Ved valg af reguleringssystem – og sikkerhedsniveau – kan man f.eks. støtte sig til EN954-1 (sikkerhedsrelaterede bestanddele i reguleringssystemet.)

Alle Fabrikate und Typen von Wegeventilen – einschließlich Proportionalventile – können versagen und schlimme Unfälle verursachen. Es ist daher wichtig, die Anwendung in allen Details zu analysieren. Weil Proportionalventile unter vielen unterschiedlichen Arbeitsbedingungen und in vielen verschiedenen Anwendungen benutzt werden, trägt allein der Maschinenhersteller die Verantwortung für seine endgültige Wahl von Produkt, und er ist ebenfalls dafür verantwortlich, dass alle Leistungs-, Sicherheits- und Warnungsanforderungen an seine Maschine erfüllt sind. Zur Wahl vom Reglersystem und Sicherheitsniveau kann man sich z.B. auf EN954-1 stützen

All marks and all types of directional control valves – inclusive proportional valves – can fail and cause serious damage. It is therefore important to analyse all aspects of the application. Because the proportional valves are used in many different operation conditions and applications, the manufacturer of the application is alone responsible for making the final selection of the products – and assuring that all performance, safety and warning requirements of the application are met. The process of choosing the control system – and safety level – could e.g. be governed by EN 954-1 (Safety related parts of control system). See also Technical information for PVE series 4

Tous les distributeurs - y compris les distributeurs proportionnels - peuvent tomber en panne et entraîner de sérieux dommages. C'est la raison pour laquelle il est important d'analyser chaque aspect de l'application. Les vannes proportionnelles étant utilisées dans de nombreuses conditions d'exploitation et applications différentes, le fabricant de l'application porte l'entière responsabilité de la sélection finale des produits et du respect des exigences en matière de rendement, de sécurité et d'avertissement. Le choix du système de commande – et du niveau de sécurité – peut être fait par exemple sur la base de la norme EN 954-1 (parties du système de commande relatives à la sécurité). Se reporter également à Information technique pour PVE série 4

**Montage af PVE**  
**Installation of PVE**  
**Montage von PVE**  
**Installation de PVE**

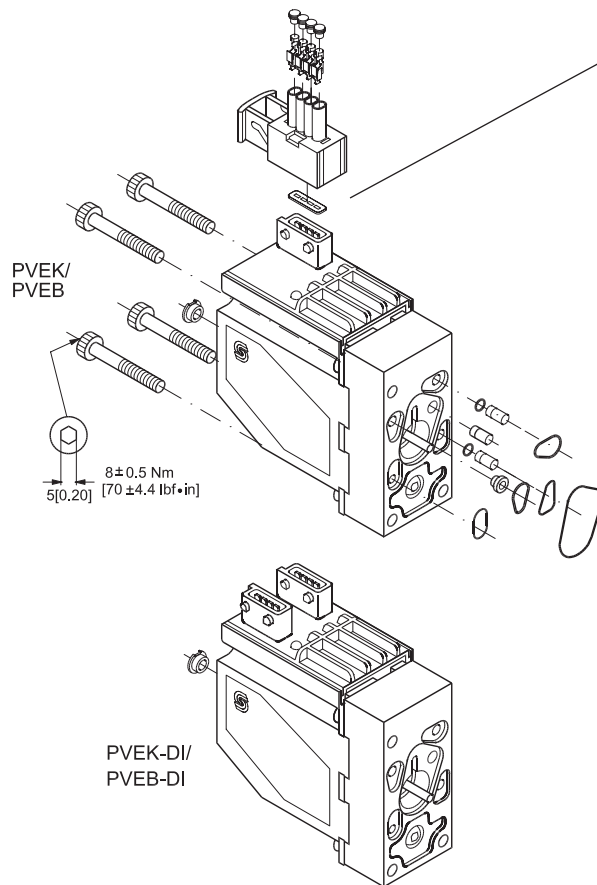

**AMP versions:**

*Pakningen i PVE stikket samt pakningerne til de enkelte ledninger, er afgørende for at korrekt tæthed af stikket opnås.*

*The seal in the PVE connector and the seals for individual conductors are crucial for correctly sealing the connector.*

*Die Dichtung im PVE-Stecker sowie die Dichtungen für die einzelnen Drähte sind für die Dichtheit des Steckers von entscheidendem Einfluss.*

*Le joint de la prise PVE ainsi que les joints de chaque conducteur, jouent un rôle essentiel dans la qualité de l'étanchéité de la prise.*

157-346.12

**Udluftning**

Hvis gruppen er monteret vertikalt, anbefales det at udlufte ved justerskruer (Pos.A)  
 Bemærk: Ved PVEA kan det, pga.dens hydrauliske opbygning, være påkrævet at foretage udluftning.

**Bleeding**

If the group is installed vertically, it is recommended to bleed it at the adjusting screws (Pos.A)  
 Note: Because of the hydraulic build-up of PVEA, it may be necessary to bleed the PVEK.

**Entlüftung**

Wenn die Gruppe vertikal montiert ist, empfehlen wir an den Justierschrauben zu entlüften (Pos.A)  
 Beachte: Wegen des hydraulischen Aufbaus von PVEA kann eine Entlüftung erforderlich sein.

**Purge**

Si l'ensemble est monté verticalement, il est recommandé de le purger au moyen des vis d'ajustage (Pos.A)  
 Nb! En raison du système hydraulique des PVEAs il peut s'avérer nécessaire de purger.

**Beskyttelse**

Alle PVE-moduler overholder tæthedsgrad IP65 i henhold til IEC 529. Det anbefales dog, at PVE'en på særligt udsatte steder beskyttes i form af en afskærmning eller lignende.

**Schutzart**

Alle PVE-Module erfüllen die Schutzart IP65 gemäß IEC 529. Es ist jedoch empfehlenswert, der PVE in besonders ausgesetzten Einsatzbereichen mit einer Abschirmung oder dergleichen zu schützen.

**Protection**

All PVE modules comply with protection class IP65 in accordance with IEC 529. However, in particularly exposed applications protection in the form of screening is recommended.

**Protection**

Tous les modules PVE possèdent le degré de protection IP65 conformément à la IEC 529. Dans les zones particulièrement exposées, il est cependant conseillé de protéger le PVE à l'aide d'un écran ou d'un dispositif similaire.

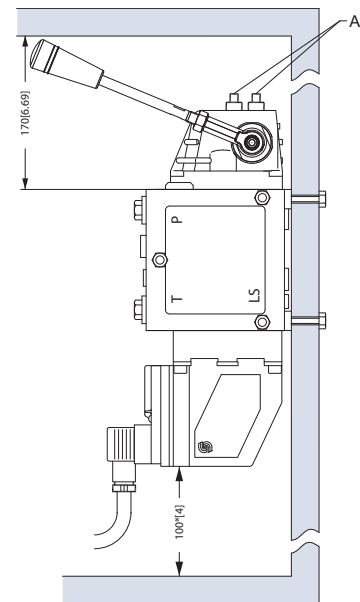

V310109.A



**Justering af PVE når max. håndtagsvandring overskrides (PVEK/PVEB er forjusteret fra fabrik)**  
**Adjustment of PVE when max. lever travel is exceeded (PVEK/PVEB is factory-preset)**  
**Justierung der PVE wenn max. Hebelwanderung überschritten wird (PVEK/PVEB ist vorjustiert ab Werk)**  
**Ajustage de la PVE quand la course maximale est excédée (est pré réglé à l'usine)**

Kontroller max. håndtagsvandring i neutralstilling

1. Sæt hydraulisk tryk på systemet
2. Tilslut forsyningspænding (UDC)  
(Signal spænding =  $0,5 \times$  UDC), eller afbryd signal-spænding (US).

Check max. lever travel in neutral position

1. Make sure the system is supplied with hydraulic power
2. Connect supply voltage (UDC)  
(Signal voltage =  $0,5 \times$  UDC), or cut off the signal voltage (US).

Max. Hebelwanderung in Neutralstellung kontrollieren:

1. Das System unter hydraulischen Druck setzen
2. Versorgungsspannung anschliessen (UDC)  
(Signalspannung =  $0,5 \times$  UDC), oder die Signalspannung (US).

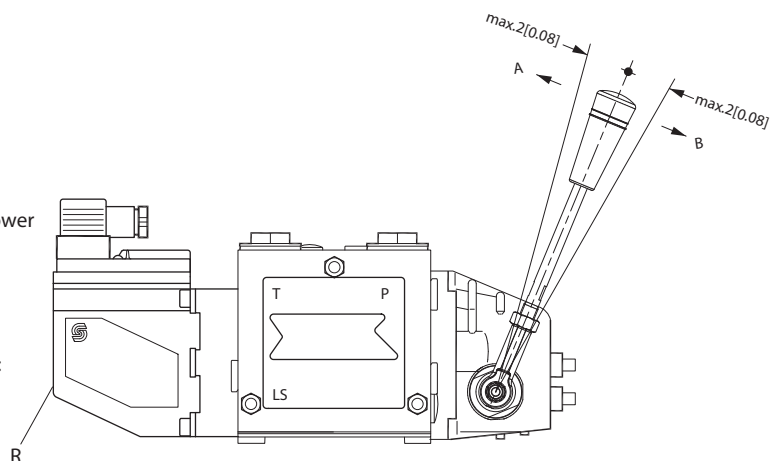

V310111.A

Contrôler la course maximale du manipulateur en position neutre

1. S'assurer que le circuit hydraulique est fourni d'huile.
2. Connecter la tension d'alimentation (UDC)  
(Tension de commande =  $0,5 \times$  UDC), ou couper la tension de commande (US).

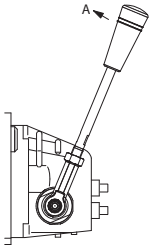
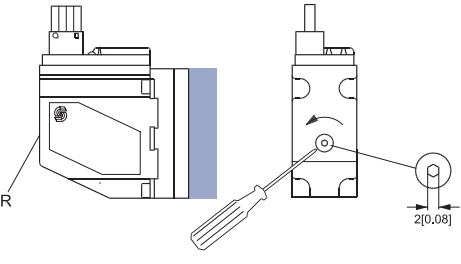
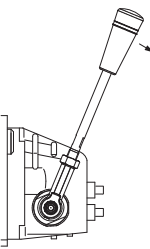
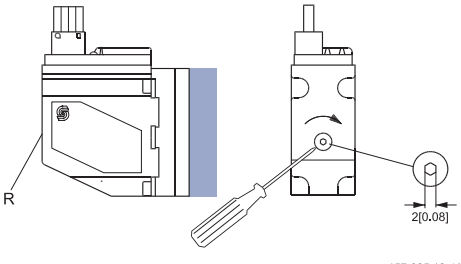
<b>Overskridelse i</b> <b>Lever travel exceeded in</b> <b>Überschreitung der Hebelwanderung in</b> <b>La course maximale est excédée du</b>	<b>PVG 32</b>	<b>Omdrejningsretning for justering af positionstransducer</b> <b>Direction of rotation for adjustment of position transducer</b> <b>Drehrichtung beim Justieren des Positionstransducers</b> <b>Sens de rotation pour l'ajustage du transducteur de position</b>
A-retning Direction A A-Richtung Sense A	 <p>V310177.A</p>	 <p>157-325.12.20</p>
B-retning Direction B B-Richtung Sense B	 <p>V310108.A</p>	 <p>157-325.12.10</p>

<b>Transducer omdrejning</b> <b>Turn of transducer</b> <b>Transducerdrehung</b> <b>Rotation du transducteur</b>	<b>Håndtagsbevægelse</b> <b>Movement of lever</b> <b>Hebelweg</b> <b>Mouvement du manipulateur</b>
1/4	1.5 mm [0.06 in]
1/2	3.0 mm [0.12 in]
3/4	4.5 mm [0.18 in]



**AMP-stik til PVE serie 4**  
**AMP connector for PVE series 4**  
**AMP-Stecker für PVE Serie 4**  
**Kit AMP pour PVE serie 4**

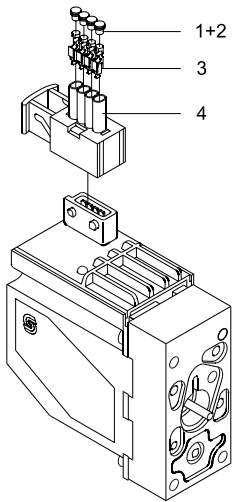

157-361.12

**PVE function (grey)**

Pos.	Description	Qty.	AMP Code no.	Sauer-Danfoss Code no.	Sauer-Danfoss Code no with 4 mm cable
1	Wire sealing (blue)	4*	828904-1	157B4992 min. 5 pcs	157B4994 min. 5 pcs.
2	Blind plug (transparent)	1	828922-1		
3	JPT contact (loose piece)	4*	929930-1		
4	JPT housing keying B (gray)	1	2-967059-1		

JPT = AMP Junior Power Timer

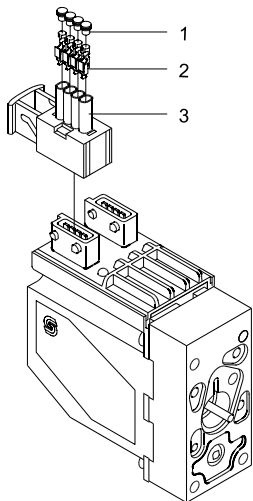

157-377.12

**DI function (black)**

Pos.	Description	Qty.	AMP Code no.	Sauer-Danfoss Code no.	Sauer-Danfoss Code no with 4 mm cable
1	Wire sealing (blue)	4	828904-1	157B4993 min. 5 pcs	157B4995 min. 5 pcs.
3	JPT contact (loose piece)	4	929930-1		
4	JPT housing keying A (black)	1	1-967059-1		

AMP crimp tool incl. crimp insert for JPT-contact

157B4989

Åbning af AMP-stik  
 Opening of AMP-connector  
 Öffnen des AMP-Steckers  
 Ouverture des kit AMP

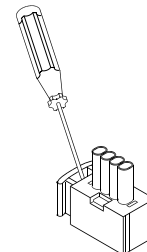

157-378.10

**Kabel med stik**  
**Cable with connector**  
**Kabel mit Stecker**  
**Câble avec connecteur**

PVE-funktion (gråt stik)  
 PVE-function (grey connector)  
 PVE-Funktion (Grauer Stecker)  
 PVE-Fonction (Support gris)

Code: 157B4994  
 (min. 5 pcs.)

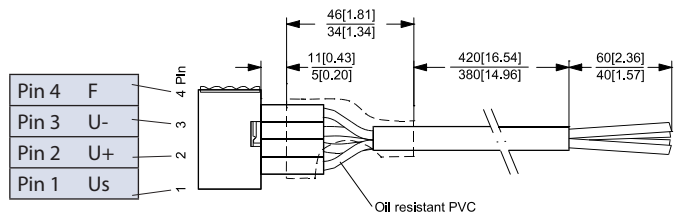

157-376.10

Pin 1	Hvid, White, Weiß, Blanche
Pin 2	Blå, Blue, Blau, Bleu
Pin 3	Gul, Yellow, Gelb, Jaune
Pin 4	Rød, Red, Rot, Rouge

DI-funktion (sort stik)  
 DI-function (black connector)  
 DI-Funktion (Schwarzer Stecker)  
 DI-fonction (Support noir)

Code: 157B4995  
 (min. 5 pcs.)

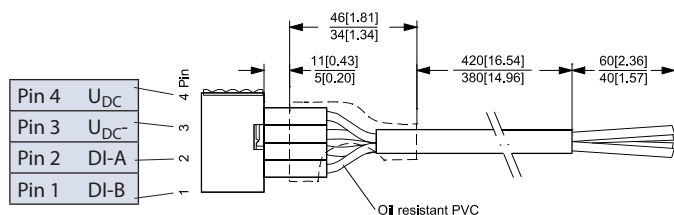

157-376.10

Kabel med Deutsch stik  
 Cable with Deutsch connector  
 Kabel mit DeutschStecker  
 Câble avec Deutsch connecteur

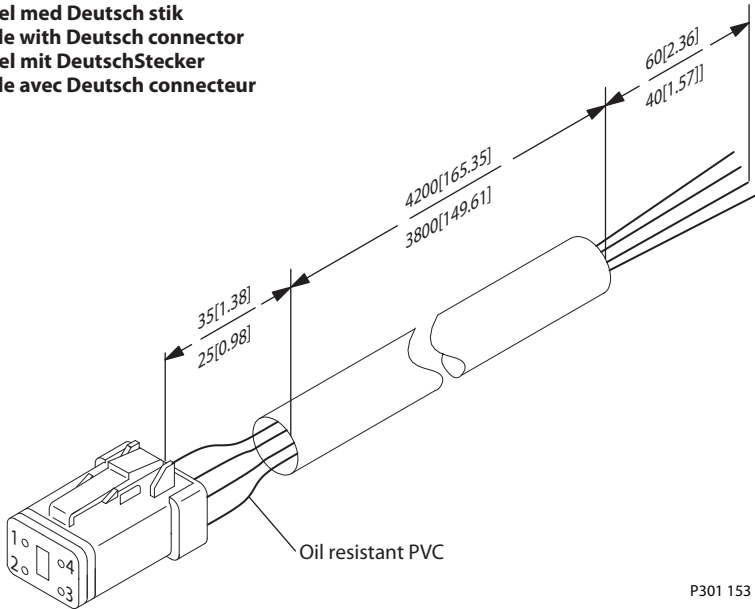

<b>Pin 1</b>	Hvid, White, Weiß, Blance
<b>Pin 2</b>	Blå, Blue, Blau, Bleu
<b>Pin 3</b>	Gul, Yellow, Gelb, Jaune
<b>Pin 4</b>	Rød, Red, Rot, Rouge

P301 153

Sample of wiring diagram

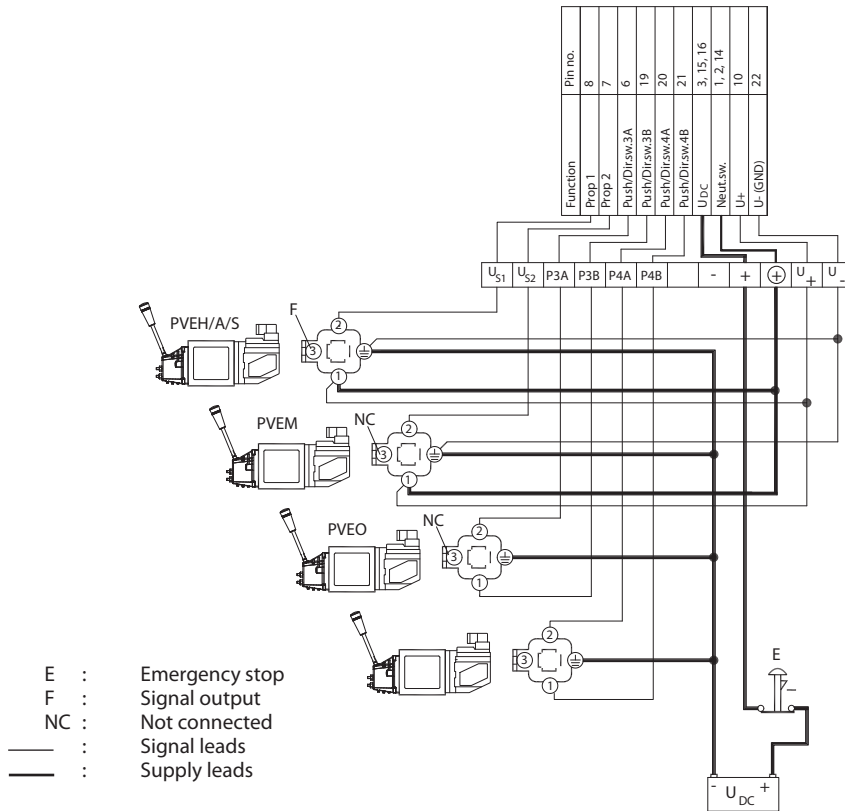
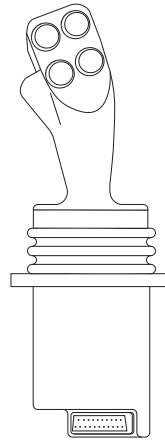

V310116.A