

F11-014
 (SAE-Version)

Eingebautes Anti-Kavitationsventil,
 (MUVR oder MUVL optional;
 Abbildungen rechtsdrehend definiert)

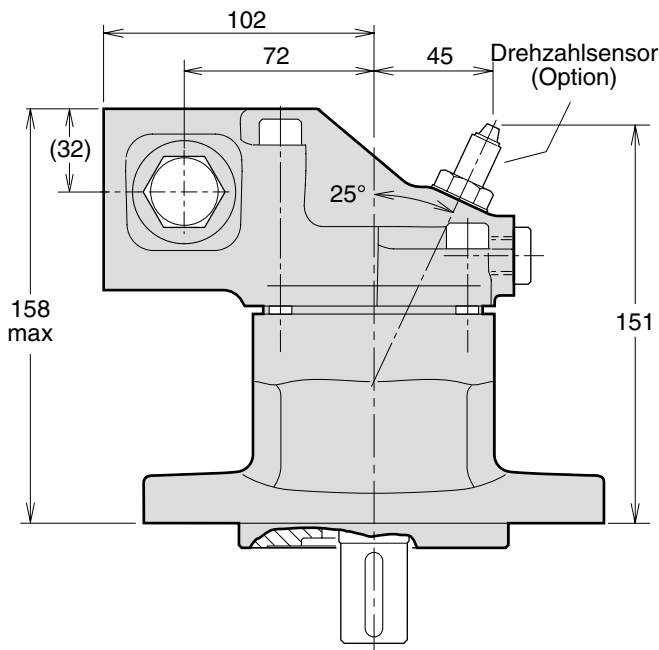

Wellenende Option

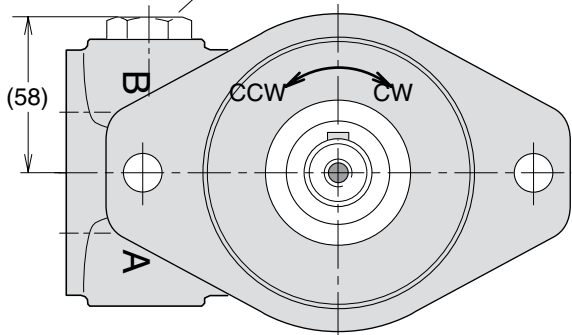
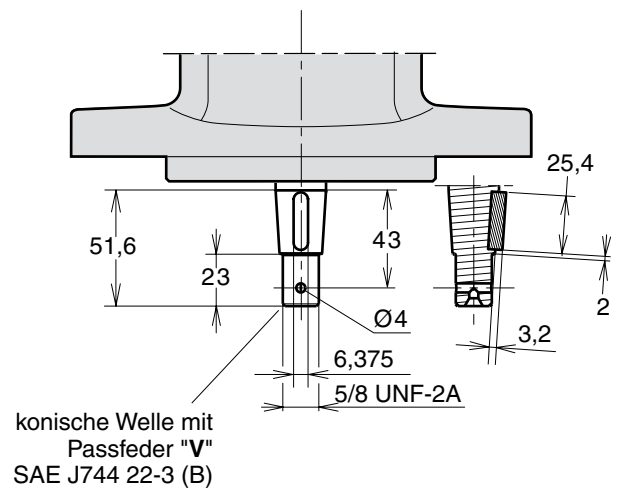
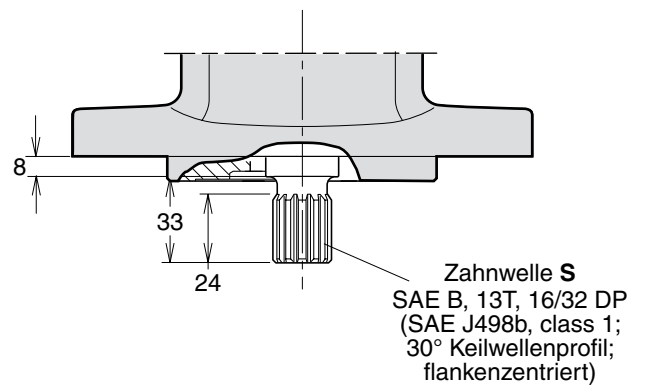
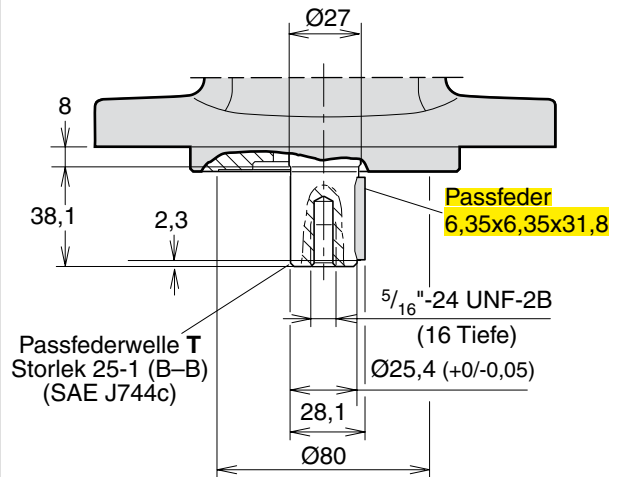

2

F11-019
 (SAE-Version)

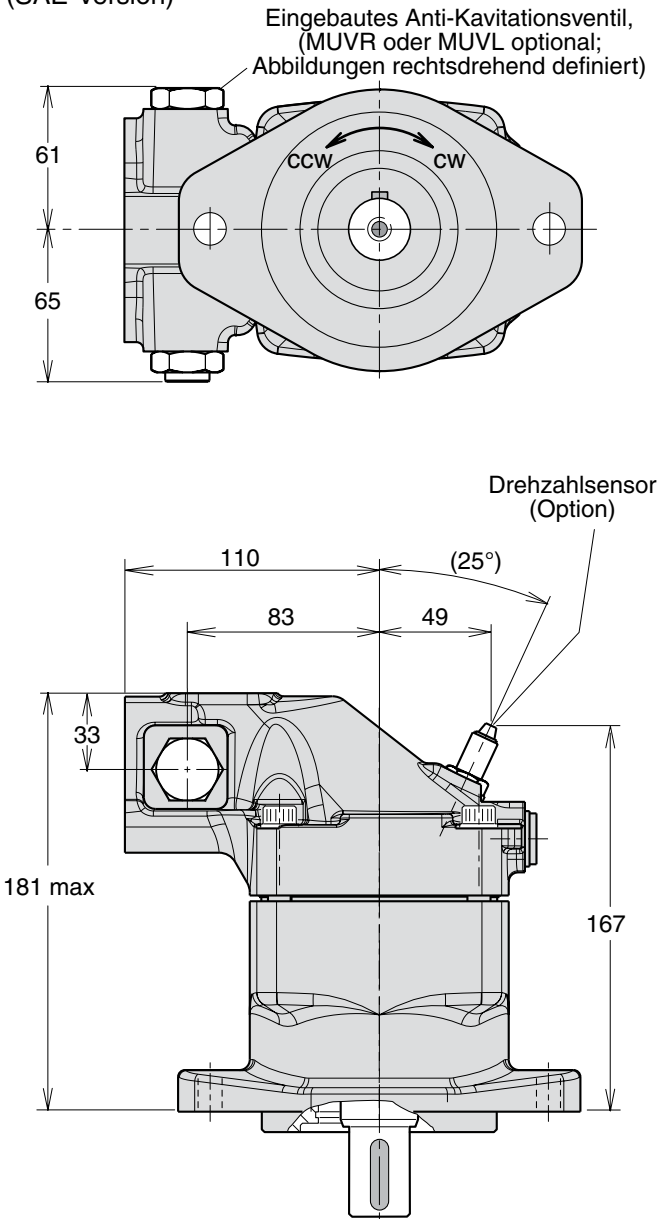

Wellenende Option

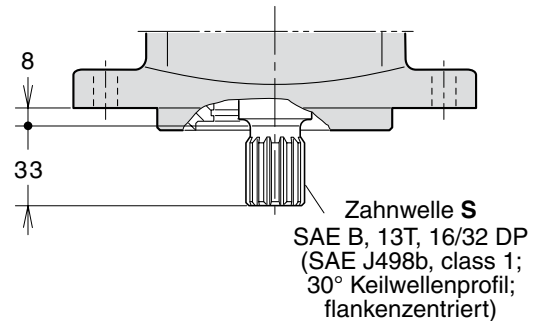
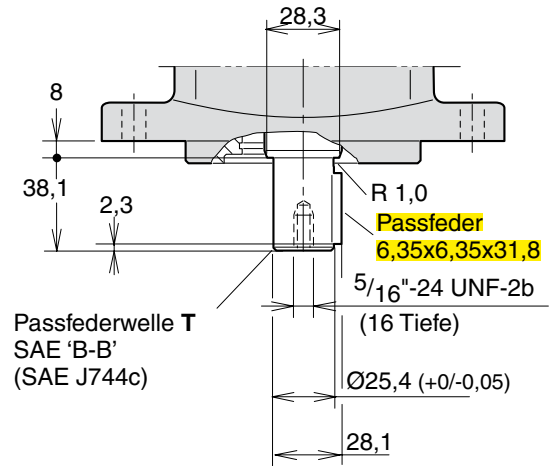

2